

IM6402/D, IM6403/D, IM6402/W, IM6403/W

Universal Asynchronous Receiver Transmitter (UART)



GENERAL DESCRIPTION

The IM6402 and IM6403 are CMOS/LSI UARTs for interfacing computers or microprocessors to asynchronous serial data channels. The receiver converts serial start, data, parity and stop bits to parallel data verifying proper code transmission, parity, and stop bits. The transmitter converts parallel data into serial form and automatically adds start, parity, and stop bits.

The data word length can be 5, 6, 7 or 8 bits. Parity may be odd or even, and parity checking and generation can be inhibited. The stop bits may be one or two (or one and one-half when transmitting 5 bit code).

The IM6402 and IM6403 can be used in a wide range of applications including modems, printers, peripherals and remote data acquisition systems. CMOS/LSI technology permits clock frequencies up to 4.0 MHz (250K Baud), an improvement of 10 to 1 over previous PMOS UART designs. Power requirements, by comparison, are reduced from 670 mW to 10 mW. Status logic increases flexibility and simplifies the user interface.

The IM6402 differs from the IM6403 in the use of five device pins as indicated in Table 1 and Figure 1.

FEATURES

- Low Power—Less Than 10 mW Typ. at 2 MHz
- Programmable Word Length, Stop Bits and Parity
- Automatic Data Formatting and Status Generation
- Compatible With Industry Standard UART's (IM6402)
- On-Chip Oscillator With External Crystal (IM6403)
- Operating Voltage—IM6402/03: 5V

Table 1

Pin	IM6402	IM6403 w/XTAL	IM6403 w/EXT CLOCK
2	N/C	Divide Control	Divide Control
17	RRC	XTAL	External Clock Input
19	Tri-State	Always Active	Always Active
22	Tri-State	Always Active	Always Active
40	TRC	XTAL	V _{SS}

ORDERING INFORMATION

Part Number	Temperature	Form
IM6402/D	+ 25°C	Dice
IM6403/D	+ 25°C	Dice
IM6402/W	+ 25°C	Wafer
IM6403/W	+ 25°C	Wafer

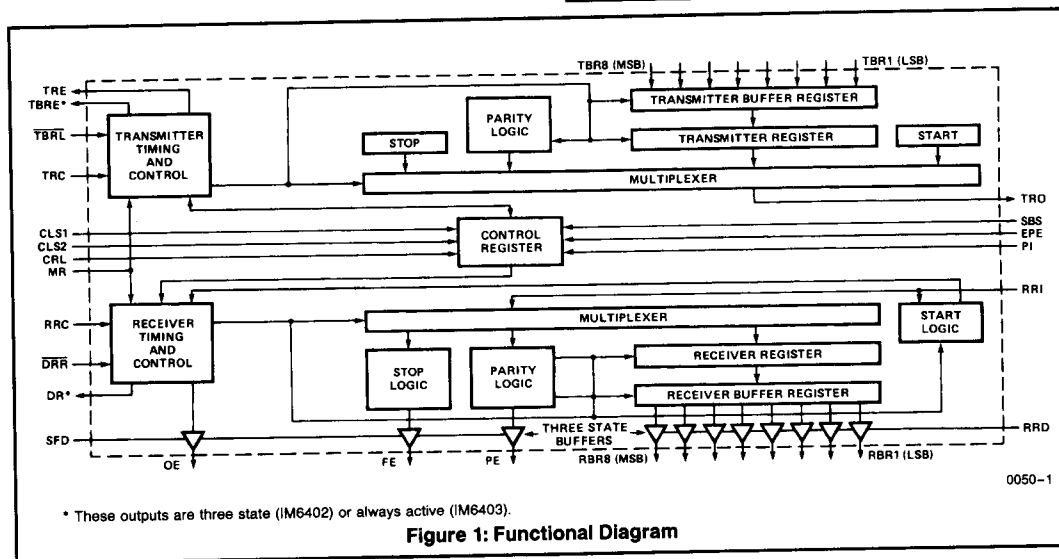

INTERMIL'S SOLE AND EXCLUSIVE WARRANTY OBLIGATION WITH RESPECT TO THIS PRODUCT SHALL BE THAT STATED IN THE WARRANTY ARTICLE OF THE CONDITION OF SALE. THE WARRANTY SHALL BE EXCLUSIVE AND SHALL BE IN LIEU OF ALL OTHER WARRANTIES, EXPRESS, IMPLIED OR STATUTORY, INCLUDING THE IMPLIED WARRANTIES OF MERCHANTABILITY AND FITNESS FOR A PARTICULAR USE.

NOTE: All typical values have been characterized but are not tested.

IM6402/D, IM6403/D, IM6402/W, IM6403/W

IM6402/D, IM6403/D, IM6402/W, IM6403/W

ABSOLUTE MAXIMUM RATINGS

Operating Temperature	IM6402/03	+ 25°C
Storage Temperature	- 65°C to + 150°C	
Operating Voltage	4.5V to 5.5V	
Supply Voltage	+ 8.0V	
Voltage On Any Input or		
Output Pin	V _{SS} - 0.3V to V _{DD} + 0.3V	

NOTE: Stresses above those listed under "Absolute Maximum Ratings" may cause permanent damage to the device. These are stress ratings only and functional operation of the device at these or any other conditions above those indicated in the operational sections of the specifications is not implied. Exposure to absolute maximum rating conditions for extended periods may cause device failures.

CHIP TOPOGRAPHY

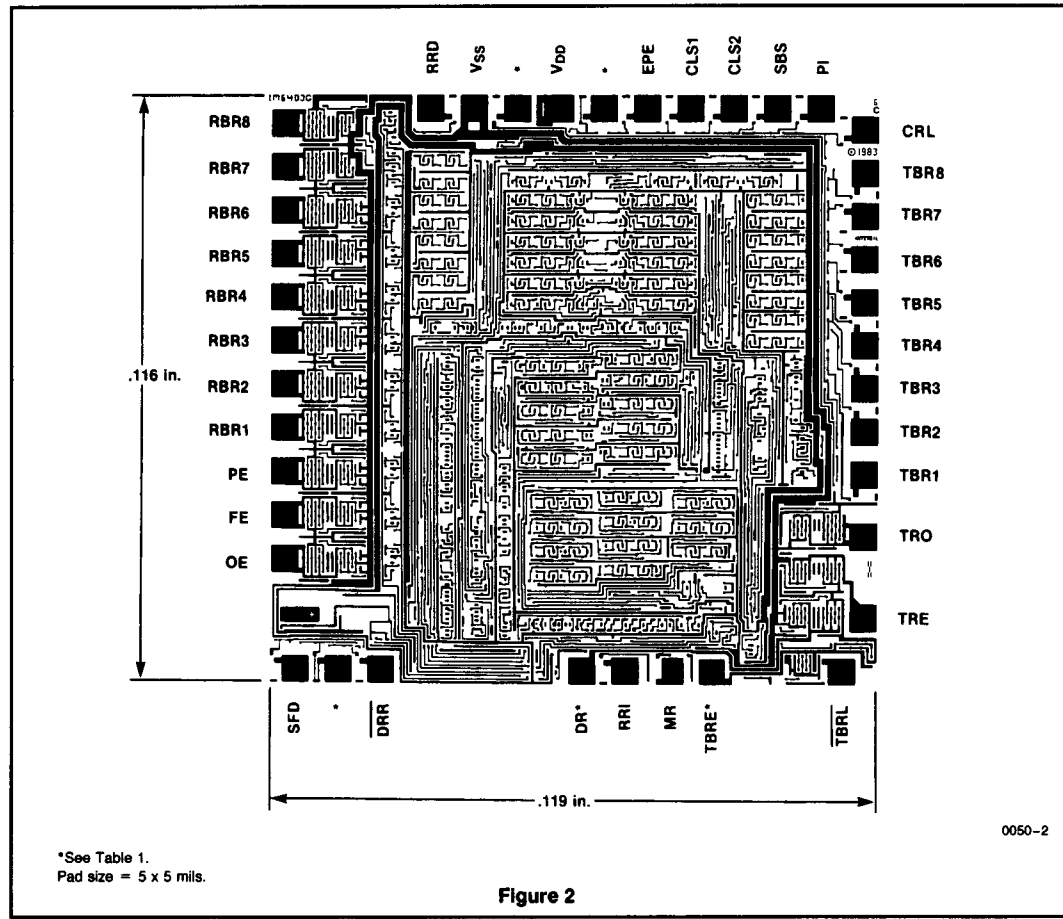

*See Table 1.
Pad size = 5 x 5 mils.

Figure 2

0050-2

INTERSIL'S SOLE AND EXCLUSIVE WARRANTY OBLIGATION WITH RESPECT TO THIS PRODUCT SHALL BE THAT STATED IN THE WARRANTY ARTICLE OF THE CONDITION OF SALE. THE WARRANTY SHALL BE EXCLUSIVE AND SHALL BE IN LIEU OF ALL OTHER WARRANTIES, EXPRESS, IMPLIED OR STATUTORY, INCLUDING THE IMPLIED WARRANTIES OF MERCHANTABILITY AND FITNESS FOR A PARTICULAR USE.

NOTE: All typical values have been characterized but are not tested.

DC CHARACTERISTICS $V_{DD} = 5.0V \pm 10\%$, $T_A = 25^\circ C$

	Symbol	Parameter	Conditions	Min	Typ	Max	Units
1	V_{IH}	Input Voltage High		$V_{DD} - 2.0$			V
2	V_{IL}	Input Voltage Low				0.8	V
3	I_{IL}	Input Leakage (Note 1)	$V_{SS} \leq V_{IN} \leq V_{DD}$	-5.0		5.0	μA
4	V_{OH}	Output Voltage High	$I_{OH} = -0.2 \text{ mA}$	2.4			V
5	V_{OL}	Output Voltage Low	$I_{OL} = V_{DD}$			0.45	V
6	I_{OL}	Output Leakage	$V_{SS} \leq V_{OUT} \leq V_{CC}$	-5.0		5.0	μA
7	I_{CC}	Power Supply Current Standby	$V_{IN} = \text{GND or } V_{CC}$		1.0		μA

NOTE 1: Except IM6403 XTAL input pins.

AC CHARACTERISTICS $V_{CC} = 5.0V \pm 10\%$, $C_L = 50 \text{ pF}$, $T_A = 25^\circ C$

	Symbol	Parameter	Conditions	Min	Typ	Max	Units
1	f_C	Clock Frequency IM6402	See Timing Diagrams (Figures 4, 5, 6)	DC	3.0	1.0	MHz
2	$f_{CRYSTAL}$	Crystal Frequency IM6403			4.0		MHz
3	t_{PW}	Pulse Widths CRL, DRR, TBRL		400	50		ns
4	t_{MR}	Pulse Width MR		510	200		ns
5	t_{DS}	Input Data Setup Time		300	20		ns
6	t_{DH}	Input Data Hold Time		300	40		ns
7	t_{EN}	Output Enable Time			80	965	ns

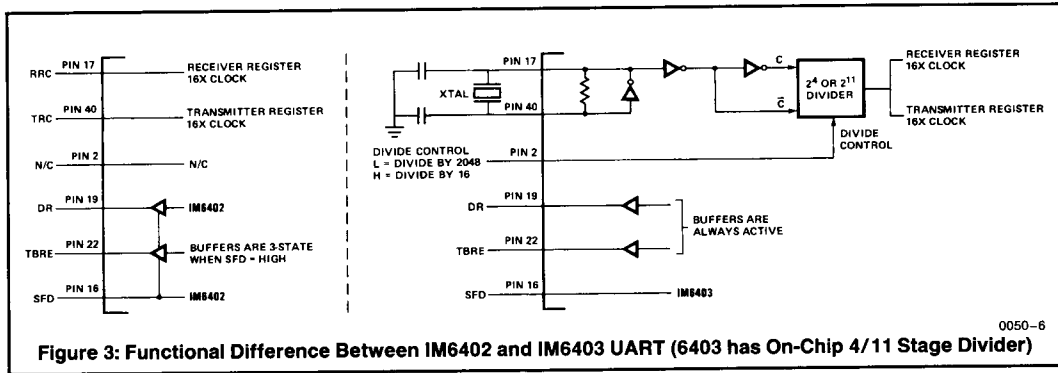

INTERSIL'S SOLE AND EXCLUSIVE WARRANTY OBLIGATION WITH RESPECT TO THIS PRODUCT SHALL BE THAT STATED IN THE WARRANTY ARTICLE OF THE CONDITION OF SALE. THE WARRANTY SHALL BE EXCLUSIVE AND SHALL BE IN LIEU OF ALL OTHER WARRANTIES, EXPRESS, IMPLIED OR STATUTORY, INCLUDING THE IMPLIED WARRANTIES OF MERCHANTABILITY AND FITNESS FOR A PARTICULAR USE.

NOTE: All typical values have been characterized but are not tested.

IM6402/D, IM6403/D, IM6402/W, IM6403/W

IM6402/D, IM6403/D, IM6402/W, IM6403/W

The IM6403 differs from the IM6402 on three inputs (RRC, TRC, pin 2) as shown in Figure 3. Two outputs (TBRE, DR) are not three-state as on the IM6402, but are always active. The on-chip divider and oscillator allow an inexpensive crystal to be used as a timing source rather than additional circuitry such as baud rate generators. For

example, a color TV crystal at 3.579545 MHz results in a baud rate of 109.2 Hz for an easy teletype interface. A 9600 baud interface may be implemented using a 2.4576 MHz crystal with the divider set to divide by 16.

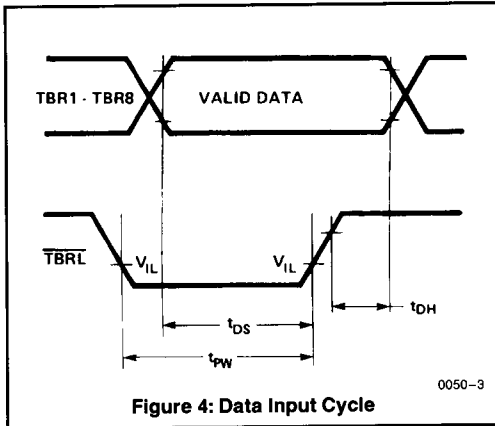

Figure 4: Data Input Cycle

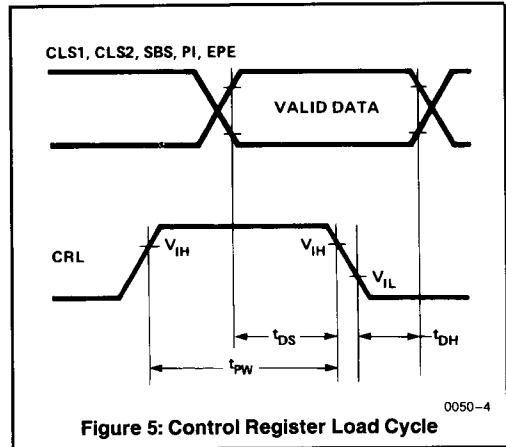

Figure 5: Control Register Load Cycle

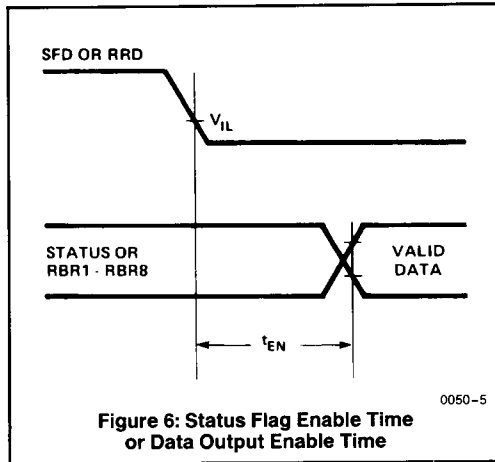

Figure 6: Status Flag Enable Time or Data Output Enable Time

INTERSIL'S SOLE AND EXCLUSIVE WARRANTY OBLIGATION WITH RESPECT TO THIS PRODUCT SHALL BE THAT STATED IN THE WARRANTY ARTICLE OF THE CONDITION OF SALE. THE WARRANTY SHALL BE EXCLUSIVE AND SHALL BE IN LIEU OF ALL OTHER WARRANTIES, EXPRESS, IMPLIED OR STATUTORY, INCLUDING THE IMPLIED WARRANTIES OF MERCHANTABILITY AND FITNESS FOR A PARTICULAR USE.

NOTE: All typical values have been characterized but are not tested.