



M48T128Y M48T128V*

5.0 or 3.3V, 1 Mbit (128 Kb x 8) TIMEKEEPER® SRAM

FEATURES SUMMARY

- INTEGRATED, ULTRA LOW POWER SRAM, REAL TIME CLOCK, POWER-FAIL CONTROL CIRCUIT, BATTERY, AND CRYSTAL
- BCD CODED YEAR, MONTH, DAY, DATE, HOURS, MINUTES, AND SECONDS
- AUTOMATIC POWER-FAIL CHIP DESELECT AND WRITE PROTECTION
- WRITE PROTECT VOLTAGES
(V_{PFD} = Power-fail Deselect Voltage):
 - M48T128Y: $V_{\text{CC}} = 4.5$ to 5.5V
 $4.1\text{V} \leq V_{\text{PFD}} \leq 4.5\text{V}$
 - M48T128V*: $V_{\text{CC}} = 3.0$ to 3.6V
 $2.7\text{V} \leq V_{\text{PFD}} \leq 3.0\text{V}$
- CONVENTIONAL SRAM OPERATION; UNLIMITED WRITE CYCLES
- SOFTWARE CONTROLLED CLOCK CALIBRATION FOR HIGH ACCURACY APPLICATIONS
- 10 YEARS OF DATA RETENTION AND CLOCK OPERATION IN THE ABSENCE OF POWER
- SELF-CONTAINED BATTERY AND CRYSTAL IN THE DIP PACKAGE
- PIN AND FUNCTION COMPATIBLE WITH JEDEC STANDARD 128K x 8 SRAMs

Figure 1. 32-pin PMDIP Module

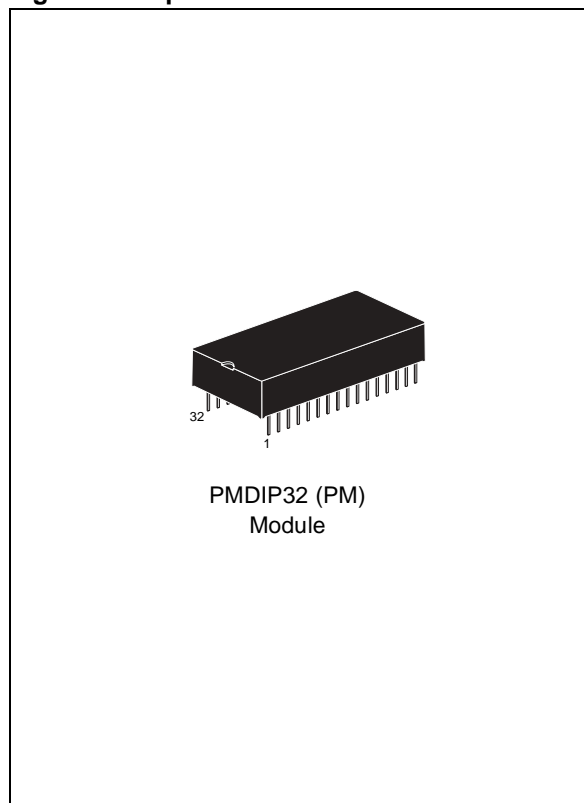

* Contact local ST sales office for availability of 3.3V version.

TABLE OF CONTENTS

| | |
|---|-----------|
| FEATURES SUMMARY | 1 |
| Figure 1. 32-pin PMDIP Module | 1 |
| SUMMARY DESCRIPTION | 4 |
| Figure 2. Logic Diagram | 4 |
| Table 1. Signal Names | 4 |
| Figure 3. DIP Connections | 4 |
| Figure 4. Block Diagram | 5 |
| OPERATION MODES | 6 |
| Table 2. Operating Modes | 6 |
| READ Mode | 7 |
| Figure 5. READ Mode AC Waveforms | 7 |
| Table 3. READ Mode AC Characteristics | 7 |
| WRITE Mode | 8 |
| Figure 6. WRITE Enable Controlled, WRITE AC Waveform | 8 |
| Figure 7. Chip Enable Controlled, WRITE AC Waveforms | 8 |
| Table 4. WRITE Mode AC Characteristics | 9 |
| Data Retention Mode | 10 |
| CLOCK OPERATIONS | 11 |
| Reading the Clock | 11 |
| Setting the Clock | 11 |
| Stopping and Starting the Oscillator | 11 |
| Table 5. Register Map | 11 |
| Calibrating the Clock | 12 |
| Figure 8. Crystal Accuracy Across Temperature | 13 |
| Figure 9. Clock Calibration | 13 |
| V_{CC} Noise And Negative Going Transients | 14 |
| Figure 10. Supply Voltage Protection | 14 |
| MAXIMUM RATING | 15 |
| Table 6. Absolute Maximum Ratings | 15 |
| DC AND AC PARAMETERS | 16 |
| Table 7. Operating and AC Measurement Conditions | 16 |
| Figure 11. AC Testing Load Circuit | 16 |
| Table 8. Capacitance | 16 |
| Table 9. DC Characteristics | 17 |
| Figure 12. Power Down/Up Mode AC Waveforms | 18 |
| Table 10. Power Down/Up AC Characteristics | 18 |
| Table 11. Power Down/Up Trip Points DC Characteristics | 18 |

PACKAGE MECHANICAL INFORMATION **19**
 Figure 13.PMDIP32 – 32-pin Plastic Module DIP, Package Outline 19
 Table 12. PMDIP32 – 32-pin Plastic Module DIP, Package Mechanical Data 19

PART NUMBERING **20**
 Table 13. Ordering Information Scheme 20

REVISION HISTORY..... **21**
 Table 14. Document Revision History 21

SUMMARY DESCRIPTION

The M48T128Y/V TIMEKEEPER® RAM is a 128Kb x 8 non-volatile static RAM and real time clock. The special DIP package provides a fully integrated battery back-up memory and real time clock solution. The M48T128Y/V directly replaces industry standard 128Kb x 8 SRAM.

It also provides the non-volatility of Flash without any requirement for special WRITE timing or limitations on the number of WRITES that can be performed. The 32-pin, 600mil DIP Hybrid houses a controller chip, SRAM, quartz crystal, and a long life lithium button cell in a single package.

Figure 2. Logic Diagram

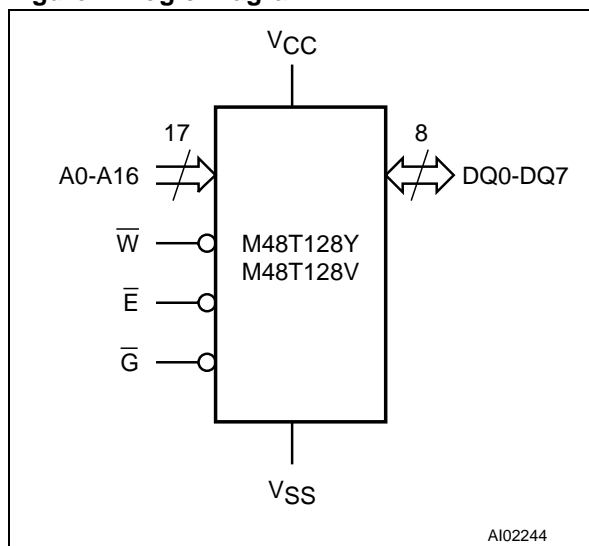

Table 1. Signal Names

| | |
|-----------|--------------------------|
| A0-A16 | Address Inputs |
| DQ0-DQ7 | Data Inputs / Outputs |
| \bar{E} | Chip Enable |
| \bar{G} | Output Enable |
| \bar{W} | WRITE Enable |
| VCC | Supply Voltage |
| VSS | Ground |
| NC | Not Connected Internally |

Figure 3. DIP Connections

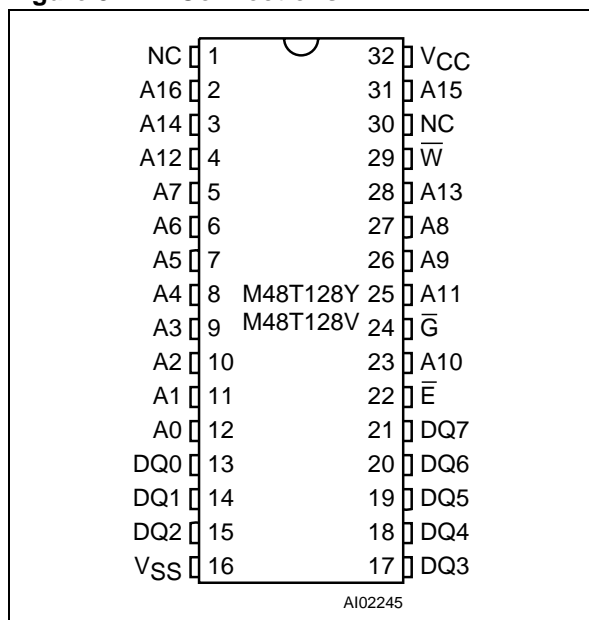
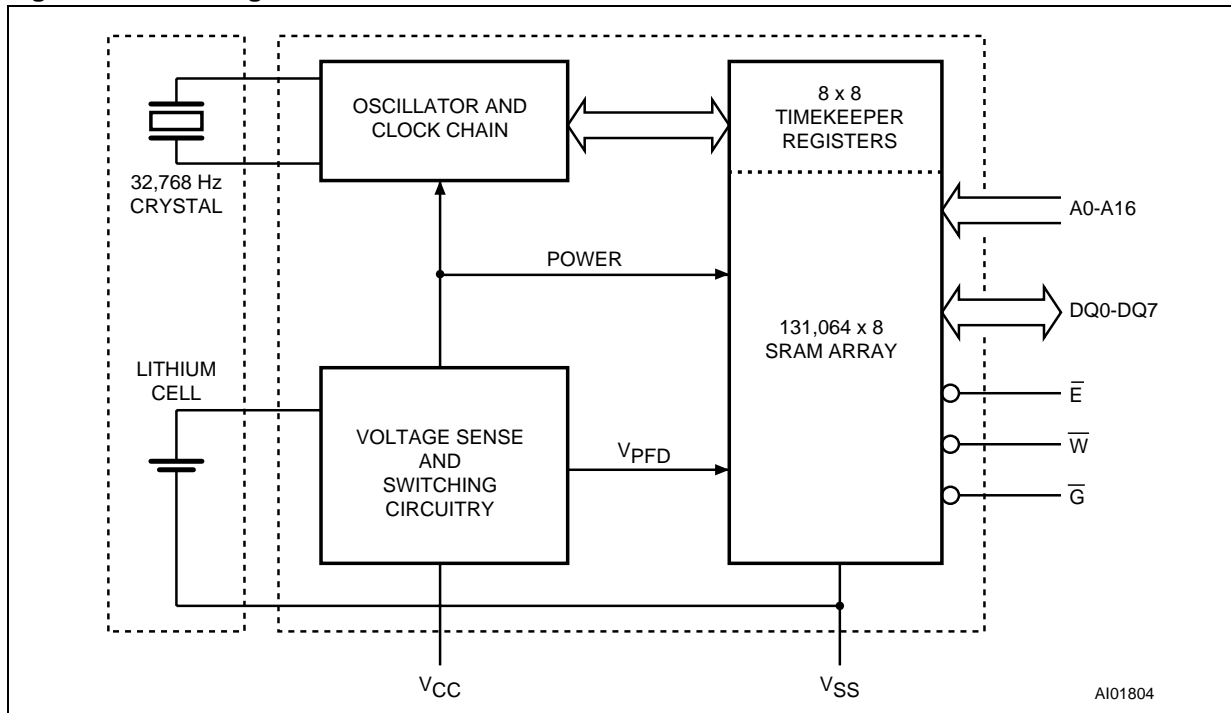

Figure 4. Block Diagram



AI01804

OPERATION MODES

Figure 4., page 5 illustrates the static memory array and the quartz controlled clock oscillator. The clock locations contain the year, month, date, day, hour, minute, and second in 24 hour BCD format. Corrections for 28, 29 (leap year - valid until 2100), 30, and 31 day months are made automatically. Byte 1FFF8h is the clock control register. This byte controls user access to the clock information and also stores the clock calibration setting. The seven clock bytes (1FFFFh - 1FFF8h) are not the actual clock counters, they are memory locations consisting of BiPORT™ READ/WRITE memory cells within the static RAM array. The M48T128Y/V includes a clock control circuit which updates the clock bytes with current information once per sec-

ond. The information can be accessed by the user in the same manner as any other location in the static memory array. The M48T128Y/V also has its own Power-Fail Detect circuit. This control circuitry constantly monitors the supply voltage for an out of tolerance condition. When V_{CC} is out of tolerance, the circuit write protects the TIMEKEEPER® Register data and external SRAM, providing data security in the midst of unpredictable system operation. As V_{CC} falls below the Battery Back-up Switchover Voltage (V_{SO}), the control circuitry automatically switches to the battery, maintaining data and clock operation until valid power is restored.

Table 2. Operating Modes

| Mode | V_{CC} | \bar{E} | \bar{G} | \bar{W} | DQ0-DQ7 | Power |
|----------|--|-----------|-----------|-----------|-----------|----------------------|
| Deselect | 4.5 to 5.5V or 3.0 to 3.6V | V_{IH} | X | X | High Z | Standby |
| WRITE | | V_{IL} | X | V_{IL} | D_{IN} | Active |
| READ | | V_{IL} | V_{IL} | V_{IH} | D_{OUT} | Active |
| READ | | V_{IL} | V_{IH} | V_{IH} | High Z | Active |
| Deselect | V_{SO} to V_{PFD} (min) ⁽¹⁾ | X | X | X | High Z | CMOS Standby |
| Deselect | $\leq V_{SO}$ ⁽¹⁾ | X | X | X | High Z | Battery Back-up Mode |

Note: X = V_{IH} or V_{IL} ; V_{SO} = Battery Back-up Switchover Voltage.

1. See Table 11., page 18 for details.

READ Mode

The M48T128Y/V is in the READ Mode whenever \overline{W} (WRITE Enable) is high and \overline{E} (Chip Enable) is low. The unique address specified by the 17 Address Inputs defines which one of the 131,072 bytes of data is to be accessed.

Valid data will be available at the Data I/O pins within t_{AVQV} (Address Access Time) after the last address input signal is stable, providing the \overline{E} and \overline{G} access times are also satisfied. If the \overline{E} and \overline{G} access times are not met, valid data will be avail-

able after the latter of the Chip Enable Access Times (t_{ELQV}) or Output Enable Access Time (t_{GLQV}). The state of the eight three-state Data I/O signals is controlled by \overline{E} and \overline{G} . If the outputs are activated before t_{AVQV} , the data lines will be driven to an indeterminate state until t_{AVQV} . If the Address Inputs are changed while \overline{E} and \overline{G} remain active, output data will remain valid for t_{AXQX} (Output Data Hold Time) but will go indeterminate until the next Address Access.

Figure 5. READ Mode AC Waveforms

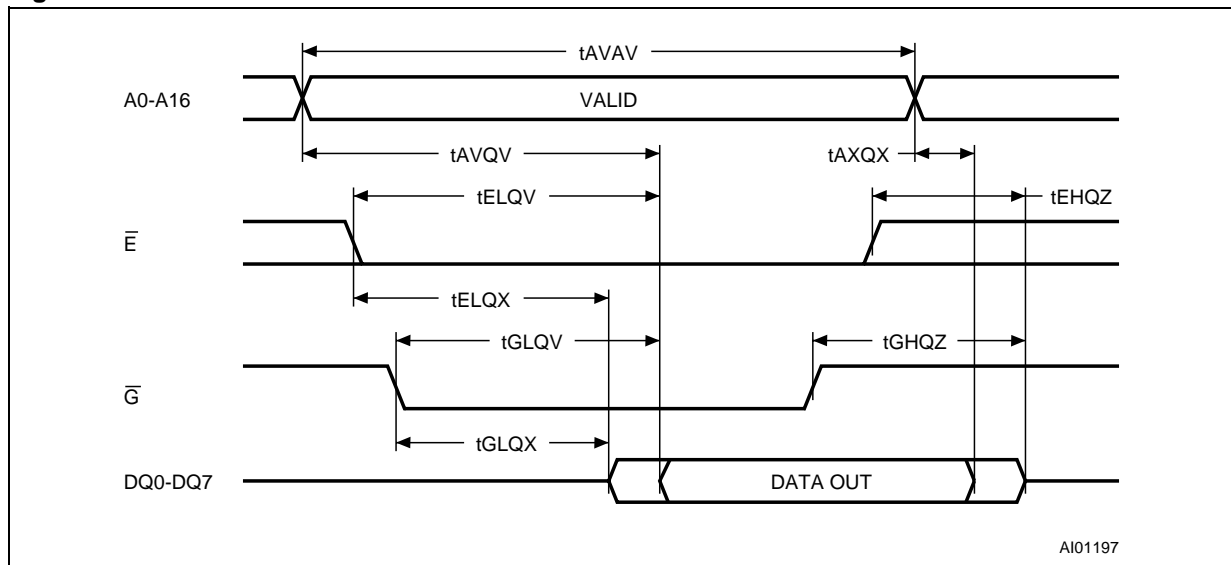

Note: \overline{WE} = High.

Table 3. READ Mode AC Characteristics

| Symbol | Parameter ⁽¹⁾ | M48T128Y | | M48T128V | | Unit |
|------------------|---|----------|-----|----------|-----|------|
| | | -70 | | -85 | | |
| | | Min | Max | Min | Max | |
| t_{AVAV} | READ Cycle Time | 70 | | 85 | | ns |
| t_{AVQV} | Address Valid to Output Valid | | 70 | | 85 | ns |
| t_{ELQV} | Chip Enable Low to Output Valid | | 70 | | 85 | ns |
| t_{GLQV} | Output Enable Low to Output Valid | | 40 | | 55 | ns |
| $t_{ELQX}^{(2)}$ | Chip Enable Low to Output Transition | 5 | | 5 | | ns |
| $t_{GLQX}^{(2)}$ | Output Enable Low to Output Transition | 5 | | 5 | | ns |
| $t_{EHQZ}^{(2)}$ | Chip Enable High to Output Hi-Z | | 25 | | 30 | ns |
| $t_{GHQZ}^{(2)}$ | Output Enable High to Output Hi-Z | | 25 | | 30 | ns |
| t_{AXQX} | Address Transition to Output Transition | 10 | | 5 | | ns |

Note: 1. Valid for Ambient Operating Temperature: $T_A = 0$ to 70°C ; $V_{CC} = 4.5$ to 5.5V or 3.0 to 3.6V (except where noted).

2. $C_L = 5\text{pF}$.

WRITE Mode

The M48T128Y/V is in the WRITE Mode whenever \overline{W} (WRITE Enable) and \overline{E} (Chip Enable) are low state after the address inputs are stable.

The start of a WRITE is referenced from the latter occurring falling edge of \overline{W} or \overline{E} . A WRITE is terminated by the earlier rising edge of \overline{W} or \overline{E} . The addresses must be held valid throughout the cycle. \overline{E} or \overline{W} must return high for a minimum of t_{EHAX} from

Chip Enable or t_{WHAX} from WRITE Enable prior to the initiation of another READ or WRITE cycle. Data-in must be valid t_{DVWH} prior to the end of WRITE and remain valid for t_{WHDX} afterward. \overline{G} should be kept high during WRITE cycles to avoid bus contention; although, if the output bus has been activated by a low on \overline{E} and \overline{G} a low on \overline{W} will disable the outputs t_{WLQZ} after \overline{W} falls.

Figure 6. WRITE Enable Controlled, WRITE AC Waveform

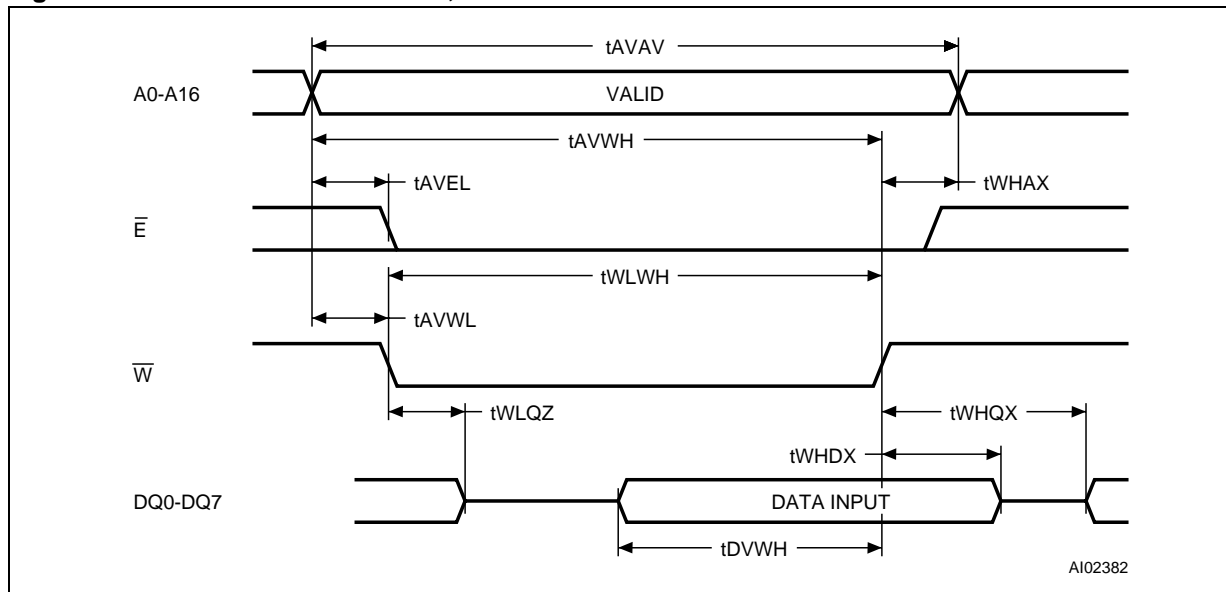

Figure 7. Chip Enable Controlled, WRITE AC Waveforms

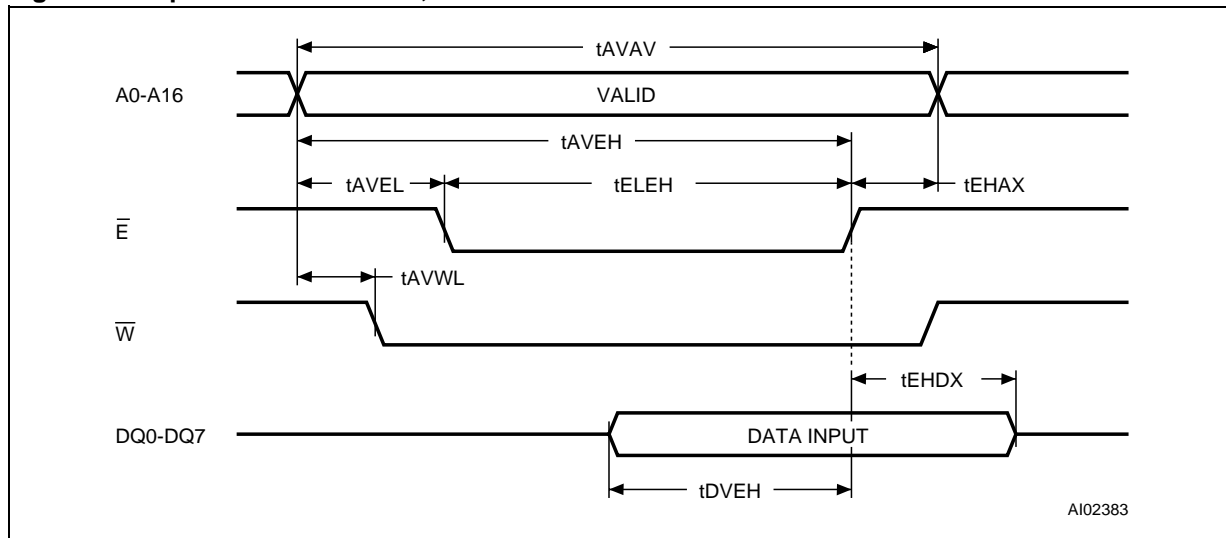

Table 4. WRITE Mode AC Characteristics

| Symbol | Parameter ⁽¹⁾ | M48T128Y | | M48T128V | | Unit |
|------------------------------------|---|----------|-----|----------|-----|------|
| | | -70 | | -85 | | |
| | | Min | Max | Min | Max | |
| t _{AVAV} | WRITE Cycle Time | 70 | | 85 | | ns |
| t _{AVWL} | Address Valid to WRITE Enable Low | 0 | | 0 | | ns |
| t _{AVEL} | Address Valid to Chip Enable Low | 0 | | 0 | | ns |
| t _{WLWH} | WRITE Enable Pulse Width | 50 | | 60 | | ns |
| t _{LEH} | Chip Enable Low to Chip Enable 1 High | 55 | | 65 | | ns |
| t _{WHAX} | WRITE Enable High to Address Transition | 5 | | 5 | | ns |
| t _{EHAX} | Chip Enable High to Address Transition | 10 | | 15 | | ns |
| t _{DWH} | Input Valid to WRITE Enable High | 30 | | 35 | | ns |
| t _{DVEH} | Input Valid to Chip Enable High | 30 | | 35 | | ns |
| t _{WHDX} | WRITE Enable High to Input Transition | 5 | | 5 | | ns |
| t _{EHDX} | Chip Enable High to Input Transition | 10 | | 15 | | ns |
| t _{WLQZ} ^(2,3) | WRITE Enable Low to Output Hi-Z | | 25 | | 30 | ns |
| t _{AVWH} | Address Valid to WRITE Enable High | 60 | | 70 | | ns |
| t _{AVEH} | Address Valid to Chip Enable High | 60 | | 70 | | ns |
| t _{WHQX} ^(2,3) | WRITE Enable High to Output Transition | 5 | | 5 | | ns |

Note: 1. Valid for Ambient Operating Temperature: T_A = 0 to 70°C; V_{CC} = 4.5 to 5.5V or 3.0 to 3.6V (except where noted).

2. C_L = 5pF.

3. If \overline{E} goes low simultaneously with \overline{W} going low, the outputs remain in the high impedance state.

Data Retention Mode

With valid V_{CC} applied, the M48T128Y/V operates as a conventional BYTEWIDE™ static RAM. Should the supply voltage decay, the RAM will automatically power-fail deselect, write protecting itself when V_{CC} falls within the V_{PFD} (max), V_{PFD} (min) window. All outputs become high impedance, and all inputs are treated as “Don't care.”

Note: A power failure during a WRITE cycle may corrupt data at the currently addressed location, but does not jeopardize the rest of the RAM's content. At voltages below V_{PFD} (min), the user can be assured the memory will be in a write protected state, provided the V_{CC} fall time is not less than t_F . The M48T128Y/V may respond to transient noise

spikes on V_{CC} that reach into the deselect window during the time the device is sampling V_{CC} . Therefore, decoupling of the power supply lines is recommended.

When V_{CC} drops below V_{SO} , the control circuit switches power to the internal battery, preserving data and powering the clock. The internal energy source will maintain data in the M48T128Y/V for an accumulated period of at least 10 years at room temperature. As system power rises above V_{SO} , the battery is disconnected, and the power supply is switched to external V_{CC} . Deselect continues for t_{REC} after V_{CC} reaches V_{PFD} (max).

CLOCK OPERATIONS

Reading the Clock

Updates to the TIMEKEEPER® registers should be halted before clock data is read to prevent reading data in transition. The BiPORT™ TIMEKEEPER cells in the RAM array are only data registers and not the actual clock counters, so updating the registers can be halted without disturbing the clock itself.

Updating is halted when a '1' is written to the READ Bit, D6 in the Control Register (1FFF8h). As long as a '1' remains in that position, updating is halted. After a halt is issued, the registers reflect the count; that is, the day, date, and time that were current at the moment the halt command was issued. All of the TIMEKEEPER registers are updated simultaneously. A halt will not interrupt an update in progress. Updating is within a second after the bit is reset to a '0.'

Setting the Clock

Bit D7 of the Control Register (1FFF8h) is the WRITE Bit. Setting the WRITE Bit to a '1,' like the

READ Bit, halts updates to the TIMEKEEPER registers. The user can then load them with the correct day, date, and time data in 24 hour BCD format (see [Table 5., page 11](#)). Resetting the WRITE Bit to a '0' then transfers the values of all time registers 1FFFh-1FFF9h to the actual TIMEKEEPER counters and allows normal operation to resume. After the WRITE Bit is reset, the next clock update will occur one second later.

Stopping and Starting the Oscillator

The oscillator may be stopped at any time. If the device is going to spend a significant amount of time on the shelf, the oscillator can be turned off to minimize current drain on the battery. The STOP Bit is located at Bit D7 within 1FFF9h. Setting it to a '1' stops the oscillator. The M48T128Y/V is shipped from STMicroelectronics with the STOP Bit set to a '1.' When reset to a '0,' the M48T128Y/V oscillator starts after one second.

Table 5. Register Map

| Address | Data | | | | | | | | Function/Range BCD Format | |
|---------|----------|------------|----------|-------------|---------|-----|----|----|------------------------------|-------|
| | D7 | D6 | D5 | D4 | D3 | D2 | D1 | D0 | | |
| 1FFFfH | 10 Years | | | | Year | | | | Year | 00-99 |
| 1FFFEh | 0 | 0 | 0 | 10 M | Month | | | | Month | 01-12 |
| 1FFFDh | 0 | 0 | 10 Date | | Date | | | | Date | 01-31 |
| 1FFFCCh | 0 | FT | 0 | 0 | 0 | Day | | | Day | 01-07 |
| 1FFFBh | 0 | 0 | 10 Hours | | Hours | | | | Hours | 00-23 |
| 1FFFAh | 0 | 10 Minutes | | | Minutes | | | | Minutes | 00-59 |
| 1FFF9h | ST | 10 Seconds | | | Seconds | | | | Seconds | 00-59 |
| 1FFF8h | W | R | S | Calibration | | | | | Control | |

Keys: S = SIGN Bit
 R = READ Bit
 W = WRITE Bit
 ST = STOP Bit
 0 = Must be set to '0'
 Z = '0' and are Read only
 Y = '1' or '0'

Calibrating the Clock

The M48T128Y/V is driven by a quartz controlled oscillator with a nominal frequency of 32,768Hz. The devices are factory calibrated at 25°C and tested for accuracy. Clock accuracy will not exceed 35 ppm (parts per million) oscillator frequency error at 25°C, which equates to about ± 1.53 minutes per month. When the Calibration circuit is properly employed, accuracy improves to better than $+1/-2$ ppm at 25°C. The oscillation rate of crystals changes with temperature (see [Figure 8.](#), [page 13](#)). The M48T128Y/V design employs periodic counter correction. The calibration circuit adds or subtracts counts from the oscillator divider circuit at the divide by 128 stage, as shown in [Figure 9.](#), [page 13](#).

The number of times pulses are blanked (subtracted, negative calibration) or split (added, positive calibration) depends upon the value loaded into the five Calibration bits found in the Control Register. Adding counts speeds the clock up, subtracting counts slows the clock down. The Calibration bits occupy the five lower order bits (D4-D0) in the Control Register 1FFF8h. These bits can be set to represent any value between 0 and 31 in binary form. Bit D5 is a Sign Bit; '1' indicates positive calibration, '0' indicates negative calibration. Calibration occurs within a 64 minute cycle. The first 62 minutes in the cycle may, once per minute, have one second either shortened by 128 or lengthened by 256 oscillator cycles. If a binary '1' is loaded into the register, only the first 2 minutes in the 64 minute cycle will be modified; if a binary 6 is load-

ed, the first 12 will be affected, and so on. Therefore, each calibration step has the effect of adding 512 or subtracting 256 oscillator cycles for every 125, 829, 120 actual oscillator cycles, that is $+4.068$ or -2.034 ppm of adjustment per calibration step in the calibration register. Assuming that the oscillator is running at exactly 32,768Hz, each of the 31 increments in the Calibration byte would represent $+10.7$ or -5.35 seconds per month which corresponds to a total range of $+5.5$ or -2.75 minutes per month.

One method is available for ascertaining how much calibration a given M48T128Y/V may require. This involves setting the clock, letting it run for a month and comparing it to a known accurate reference and recording deviation over a fixed period of time.

Calibration values, including the number of seconds lost or gained in a given period, can be found in the STMicroelectronics Application Note, "TIMEKEEPER CALIBRATION."

This allows the designer to give the end user the ability to calibrate the clock as the environment requires, even if the final product is packaged in a non-user serviceable enclosure. The designer could provide a simple utility that accesses the Calibration byte. For example, a deviation of 21 seconds slow over a period of 30 days would indicate a -8 ppm oscillator frequency error, requiring a $+2$ (WR100010) to be loaded into the Calibration Byte for correction.

Figure 8. Crystal Accuracy Across Temperature

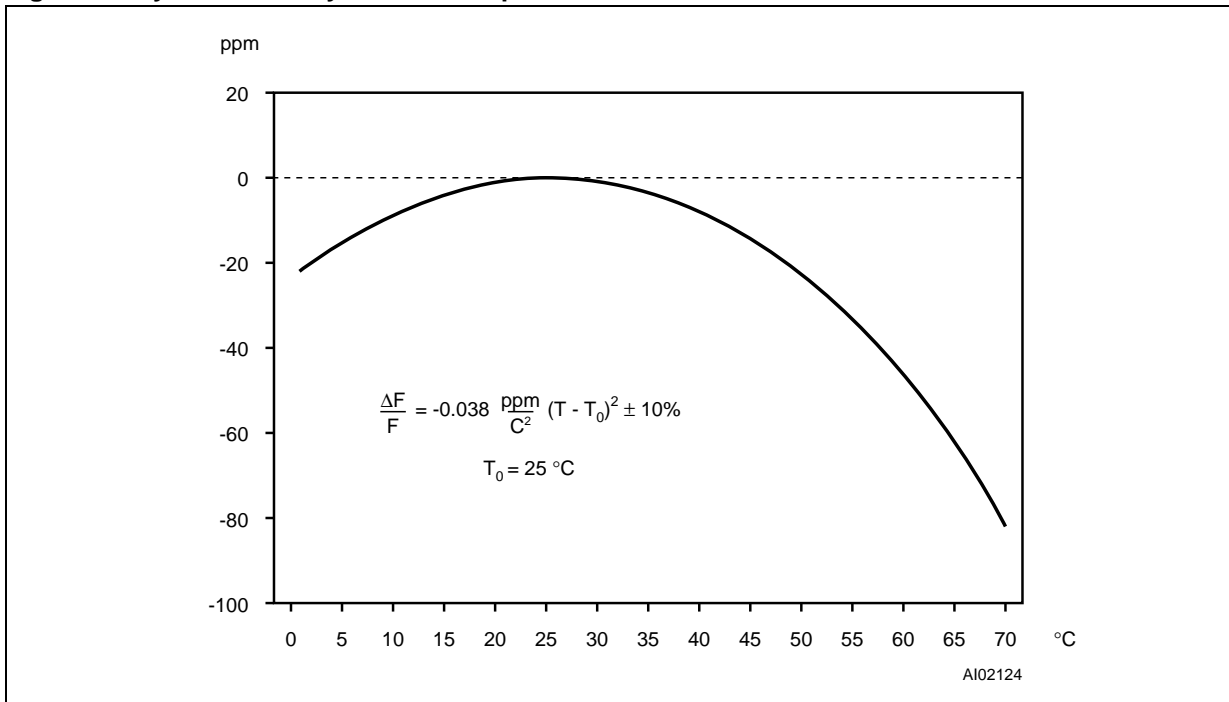
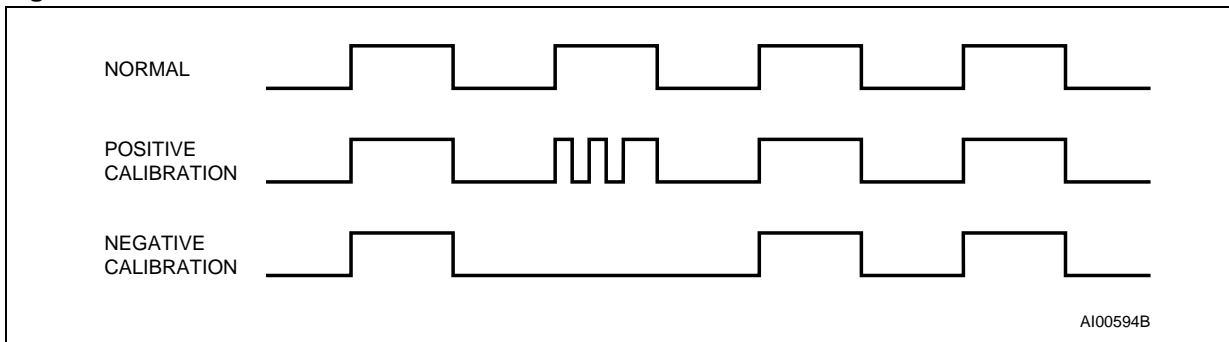

Figure 9. Clock Calibration



V_{CC} Noise And Negative Going Transients

I_{CC} transients, including those produced by output switching, can produce voltage fluctuations, resulting in spikes on the V_{CC} bus. These transients can be reduced if capacitors are used to store energy which stabilizes the V_{CC} bus. The energy stored in the bypass capacitors will be released as low going spikes are generated or energy will be absorbed when overshoots occur. A ceramic bypass capacitor value of 0.1μF (as shown in Figure 10) is recommended in order to provide the needed filtering.

In addition to transients that are caused by normal SRAM operation, power cycling can generate negative voltage spikes on V_{CC} that drive it to values below V_{SS} by as much as one volt. These negative spikes can cause data corruption in the SRAM while in battery backup mode. To protect from these voltage spikes, it is recommended to connect a schottky diode from V_{CC} to V_{SS} (cathode connected to V_{CC}, anode to V_{SS}). Schottky diode 1N5817 is recommended for through hole and MBRS120T3 is recommended for surface mount.

Figure 10. Supply Voltage Protection

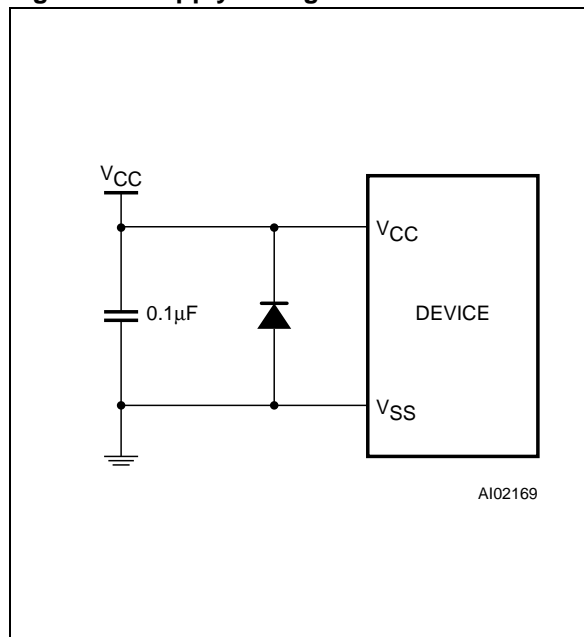

MAXIMUM RATING

Stressing the device above the rating listed in the “Absolute Maximum Ratings” table may cause permanent damage to the device. These are stress ratings only and operation of the device at these or any other conditions above those indicated in the Operating sections of this specification is

not implied. Exposure to Absolute Maximum Rating conditions for extended periods may affect device reliability. Refer also to the STMicroelectronics SURE Program and other relevant quality documents.

Table 6. Absolute Maximum Ratings

| Symbol | Parameter | Value | Unit |
|---------------------------------|---|-----------|-------------|
| T _A | Ambient Operating Temperature | 0 to 70 | °C |
| T _{STG} | Storage Temperature (V _{CC} Off, Oscillator Off) | -40 to 85 | °C |
| T _{SLD} ⁽¹⁾ | Lead Solder Temperature for 10 seconds | 260 | °C |
| V _{IO} | Input or Output Voltages | -0.3 to 7 | V |
| V _{CC} | Supply Voltage | M48T128Y | -0.3 to 7 |
| | | M48T128V | -0.3 to 4.6 |
| I _O | Output Current | 20 | mA |
| P _D | Power Dissipation | 1 | W |

Note: 1. Soldering temperature not to exceed 260°C for 10 seconds (total thermal budget not to exceed 150°C for longer than 30 seconds). No preheat above 150°C, or direct exposure to IR reflow (or IR preheat) allowed, to avoid damaging the Lithium battery.

CAUTION: Negative undershoots below -0.3V are not allowed on any pin while in the Battery Back-up mode.

DC AND AC PARAMETERS

This section summarizes the operating and measurement conditions, as well as the DC and AC characteristics of the device. The parameters in the following DC and AC Characteristic tables are derived from tests performed under the Measure-

ment Conditions listed in the relevant tables. Designers should check that the operating conditions in their projects match the measurement conditions when using the quoted parameters.

Table 7. Operating and AC Measurement Conditions

| Parameter | M48T128Y | M48T128V | Unit |
|---|------------|------------|------|
| Supply Voltage (V _{CC}) | 4.5 to 5.5 | 3.0 to 3.6 | V |
| Ambient Operating Temperature (T _A) | 0 to 70 | 0 to 70 | °C |
| Load Capacitance (C _L) | 100 | 50 | pF |
| Input Rise and Fall Times | ≤ 5 | ≤ 5 | ns |
| Input Pulse Voltages | 0 to 3 | 0 to 3 | V |
| Input and Output Timing Ref. Voltages | 1.5 | 1.5 | V |

Note: Output Hi-Z is defined as the point where data is no longer driven.

Figure 11. AC Testing Load Circuit

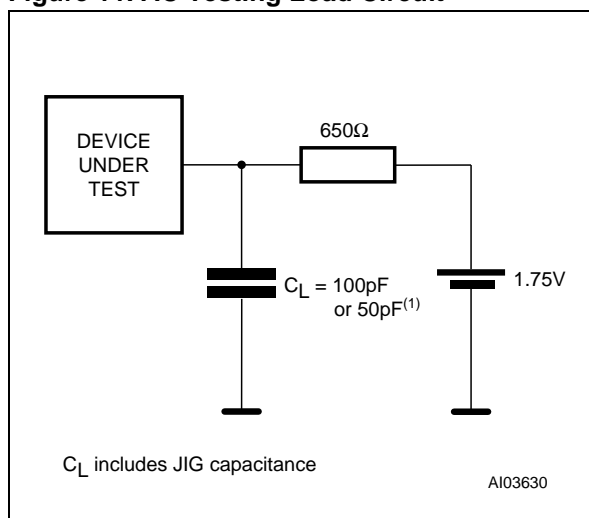

Note: 50pF for M48T128V.

Table 8. Capacitance

| Symbol | Parameter ^(1,2) | Min | Max | Unit |
|--------------------------------|----------------------------|-----|-----|------|
| C _{IN} | Input Capacitance | | 20 | pF |
| C _{IO} ⁽³⁾ | Input / Output Capacitance | | 20 | pF |

Note: 1. Effective capacitance measured with power supply at 5V. Sampled only, not 100% tested.
 2. At 25°C, f = 1MHz.
 3. Outputs deselected.

Table 9. DC Characteristics

| Symbol | Parameter | Test Condition ⁽¹⁾ | M48T128Y | | M48T128V | | Unit |
|--------------------------------|----------------------------------|-------------------------------|----------|-----------------------|----------|-----------------------|------|
| | | | -70 | | -85 | | |
| | | | Min | Max | Min | Max | |
| I _{LI} | Input Leakage Current | $0V \leq V_{IN} \leq V_{CC}$ | | ±2 | | ±2 | µA |
| I _{LO} ⁽²⁾ | Output Leakage Current | $0V \leq V_{OUT} \leq V_{CC}$ | | ±2 | | ±2 | µA |
| I _{CC} | Supply Current | Outputs open | | 95 | | 50 | mA |
| I _{CC1} | Supply Current (Standby) TTL | $\bar{E} = V_{IH}$ | | 8 | | 4 | mA |
| I _{CC2} | Supply Current (Standby) CMOS | $\bar{E} = V_{CC} - 0.2V$ | | 4 | | 3 | mA |
| V _{IL} | Input Low Voltage | | -0.3 | 0.8 | -0.3 | 0.4 | V |
| V _{IH} | Input High Voltage | | 2.2 | V _{CC} + 0.3 | 2.2 | V _{CC} + 0.3 | V |
| V _{OL} | Output Low Voltage | I _{OL} = 2.1mA | | 0.4 | | 0.4 | V |
| V _{OH} | Output High Voltage | I _{OH} = -1mA | 2.4 | | 2.2 | | V |

Note: 1. Valid for Ambient Operating Temperature: T_A = 0 to 70°C; V_{CC} = 4.5 to 5.5V or 3.0 to 3.6V (except where noted).
2. Outputs deselected.

Figure 12. Power Down/Up Mode AC Waveforms

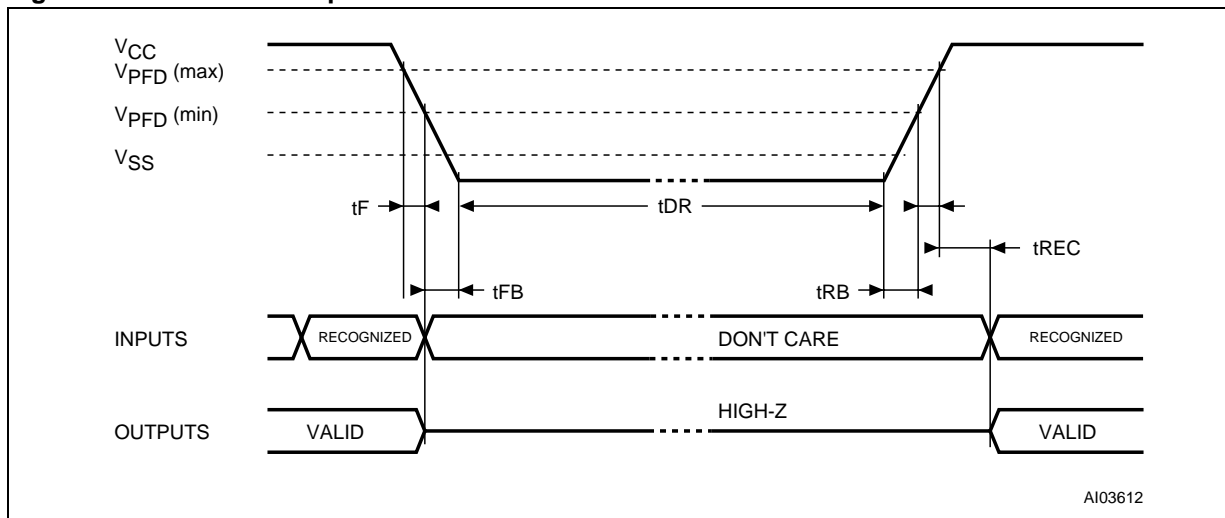

Table 10. Power Down/Up AC Characteristics

| Symbol | Parameter ⁽¹⁾ | Min | Max | Unit |
|--------------------------------|--|-----|-----|------|
| t _F ⁽²⁾ | V _{PFD} (max) to V _{PFD} (min) V _{CC} Fall Time | 300 | | μs |
| t _{FB} ⁽³⁾ | V _{PFD} (min) to V _{SS} V _{CC} Fall Time | 10 | | μs |
| t _R | V _{PFD} (min) to V _{PFD} (max) V _{CC} Rise Time | 0 | | μs |
| t _{RB} | V _{SS} to V _{PFD} (min) V _{CC} Rise Time | 1 | | μs |
| t _{REC} | V _{PFD} (max) to Inputs Recognized | 40 | 200 | ms |

Note: 1. Valid for Ambient Operating Temperature: T_A = 0 to 70°C; V_{CC} = 4.5 to 5.5V or 3.0 to 3.6V (except where noted).
 2. V_{PFD} (max) to V_{PFD} (min) fall time of less than t_F may result in deselection/write protection not occurring until 200μs after V_{CC} passes V_{PFD} (min).
 3. V_{PFD} (min) to V_{SS} fall time of less than t_{FB} may cause corruption of RAM data.

Table 11. Power Down/Up Trip Points DC Characteristics

| Symbol | Parameter ^(1,2) | Min | Typ | Max | Unit | |
|--------------------------------|------------------------------------|----------|-----|-------------------------|-------|---|
| V _{PFD} | Power-fail Deselect Voltage | M48T128Y | 4.1 | 4.35 | 4.5 | V |
| | | M48T128V | 2.7 | 2.9 | 3.0 | V |
| V _{SO} | Battery Back-up Switchover Voltage | M48T128Y | | 3.0 | | V |
| | | M48T128V | | V _{PFD} -100mV | | V |
| t _{DR} ⁽³⁾ | Expected Data Retention Time | 10 | | | YEARS | |

Note: 1. All voltages referenced to V_{SS}.
 2. Valid for Ambient Operating Temperature: T_A = 0 to 70°C; V_{CC} = 4.5 to 5.5V or 3.0 to 3.6V (except where noted).
 3. At 25°C; V_{CC} = 0V.

PACKAGE MECHANICAL INFORMATION

Figure 13. PMDIP32 – 32-pin Plastic Module DIP, Package Outline

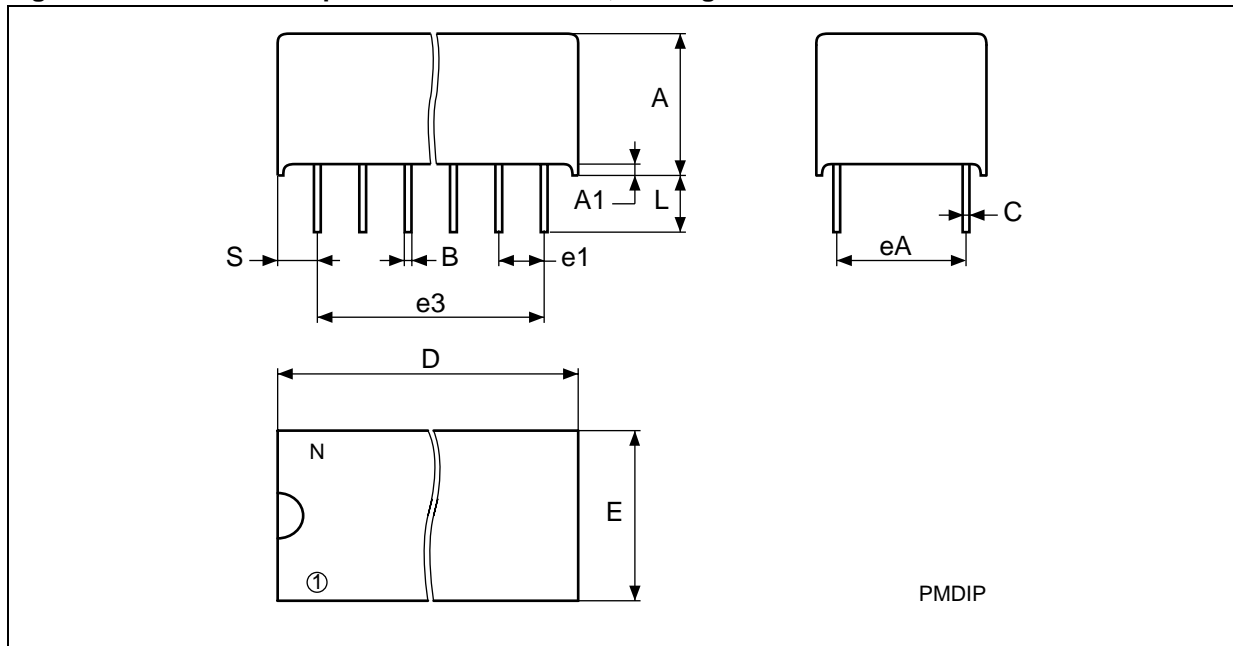

Note: Drawing is not to scale.

Table 12. PMDIP32 – 32-pin Plastic Module DIP, Package Mechanical Data

| Symb | mm | | | inches | | | |
|------|-----|-------|-------|--------|-------|-------|--|
| | Typ | Min | Max | Typ | Min | Max | |
| A | | 9.27 | 9.52 | | 0.365 | 0.375 | |
| A1 | | 0.38 | – | | 0.015 | – | |
| B | | 0.43 | 0.59 | | 0.017 | 0.023 | |
| C | | 0.20 | 0.33 | | 0.008 | 0.013 | |
| D | | 42.42 | 43.18 | | 1.670 | 1.700 | |
| E | | 18.03 | 18.80 | | 0.710 | 0.740 | |
| e1 | | 2.29 | 2.79 | | 0.090 | 0.110 | |
| e3 | | 34.29 | 41.91 | | 1.350 | 1.650 | |
| eA | | 14.99 | 16.00 | | 0.590 | 0.630 | |
| L | | 3.05 | 3.81 | | 0.120 | 0.150 | |
| S | | 1.91 | 2.79 | | 0.075 | 0.110 | |
| N | | 32 | | | 32 | | |

PART NUMBERING

Table 13. Ordering Information Scheme

| Example: | M48T | 128Y | -70 | PM | 1 | TR |
|---|------|---|--|--------------|---------------|-----------------------------------|
| Device Type | M48T | | | | | |
| Supply Voltage and Write Protect Voltage | | 128Y = $V_{CC} = 4.5$ to $5.5V$; $V_{PFD} = 4.1$ to $4.5V$ 128V ⁽¹⁾ = $V_{CC} = 3.0$ to $3.6V$; $V_{PFD} = 2.7$ to $3.0V$ | | | | |
| Speed | | | -70 = 70ns (128Y) -85 = 85ns (128V) | | | |
| Package | | | | PM = PMDIP32 | | |
| Temperature Range | | | | | 1 = 0 to 70°C | |
| Shipping Method for SOIC | | | | | | blank = Tubes TR = Tape & Reel |

Note: 1. Contact local ST sales office for availability of 3.3V version.

For other options, or for more information on any aspect of this device, please contact the ST Sales Office nearest you.

REVISION HISTORY

Table 14. Document Revision History

| Date | Version | Revision Details |
|-----------|---------|---|
| June 1998 | 1.0 | First Issue |
| 01/31/00 | 1.1 | Calibrating The Clock Paragraph changed |
| 03/30/00 | 1.2 | Storage Temperature changed (Table 6) |
| 07/20/01 | 2.0 | Reformatted; temperature information added to tables (Table 8, 9, 3, 4, 10, 11) |
| 09/21/01 | 2.1 | Corrected speed grade in ordering information |
| 05/23/02 | 2.2 | Add countries to disclaimer; add marketing status |
| 08/07/02 | 2.3 | Refine marketing status text |
| 28-Mar-03 | 3.0 | v2.2 template applied; test condition updated (Table 11) |
| 06-Aug-04 | 4.0 | Reformatted; updated Register Map (Table 5) |
| 22-Feb-05 | 5.0 | IR reflow update (Table 6) |

Information furnished is believed to be accurate and reliable. However, STMicroelectronics assumes no responsibility for the consequences of use of such information nor for any infringement of patents or other rights of third parties which may result from its use. No license is granted by implication or otherwise under any patent or patent rights of STMicroelectronics. Specifications mentioned in this publication are subject to change without notice. This publication supersedes and replaces all information previously supplied. STMicroelectronics products are not authorized for use as critical components in life support devices or systems without express written approval of STMicroelectronics.

The ST logo is a registered trademark of STMicroelectronics.

All other names are the property of their respective owners

© 2005 STMicroelectronics - All rights reserved

STMicroelectronics group of companies
Australia - Belgium - Brazil - Canada - China - Czech Republic - Finland - France - Germany - Hong Kong - India - Israel - Italy - Japan -
Malaysia - Malta - Morocco - Singapore - Spain - Sweden - Switzerland - United Kingdom - United States of America
www.st.com