



Low Supply Current, True 3-Driver/5-Receiver RS-232 Transceivers

General Description

The MAX3241 and MAX3242 have a proprietary low-dropout output stage that uses a voltage doubler to enable true RS-232 performance from 3.0V to 5.5V supplies. The devices require only four small, inexpensive external capacitors, and are guaranteed to run at data rates up to 120kbps while maintaining at least the minimum 5V RS-232 output levels.

The MAX3241/MAX3242 operate from input voltages ranging from 3.0V to 5.5V. They are ideal for 3.3V-only systems, mixed 3.3V and 5.0V systems, or 5.0V-only systems that require true RS-232 performance.

These 3 RS-232 driver/5 RS-232 receiver, complete serial ports are ideal for notebook or subnotebook computers. The MAX3241 uses tiny 0.1 μ F external capacitors and has a low 1mA max operating supply current, which reduces to just 1 μ A in shutdown mode. Two extra outputs allow the first and second receiver to remain active in shutdown. These active receivers can monitor external devices (such as a modem) in shutdown, without forward biasing the protection diodes in circuitry that may have VCC completely removed. The MAX3242 is identical to the MAX3241, except its operating supply current is 500 μ A max and it uses 1.0 μ F external capacitors.

Applications

- Notebook, Subnotebook, and Palmtop Computers
- Battery-Powered Equipment
- Hand-Held Equipment
- Peripherals

Pin Configuration

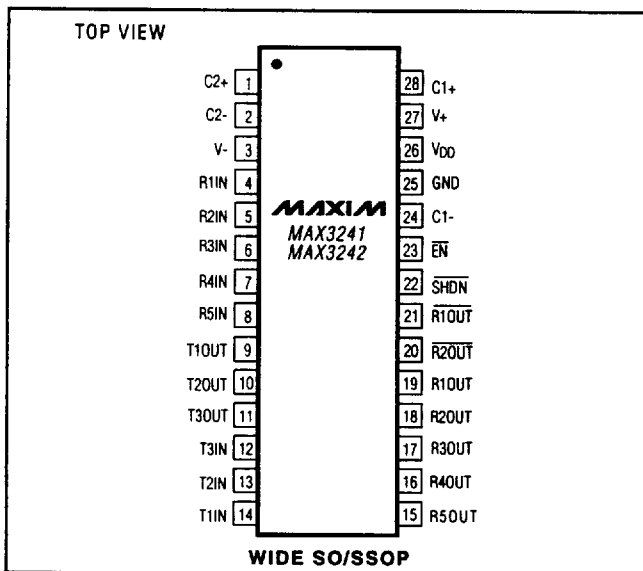

Features

- ◆ Low 500 μ A Supply Current (MAX3242)
- ◆ Small 0.1 μ F Capacitors (MAX3241)
- ◆ True RS-232 Operation from VCC = 3.0V to 5.5V
- ◆ Meets EIA/TIA-562 Specifications Down to 2.8V
- ◆ Guaranteed 120kbps Data Rate
- ◆ 1 μ A Low-Power Shutdown Mode
- ◆ 4V/ μ s Min Guaranteed Slew Rate
- ◆ Flow-Through Pinout

Ordering Information

PART	TEMP. RANGE	PIN-PACKAGE
MAX3241CWI	0°C to +70°C	28 Wide SO
MAX3241CAI	0°C to +70°C	28 SSOP
MAX3242CWI	0°C to +70°C	28 Wide SO
MAX3242CAI	0°C to +70°C	28 SSOP

Functional Diagram

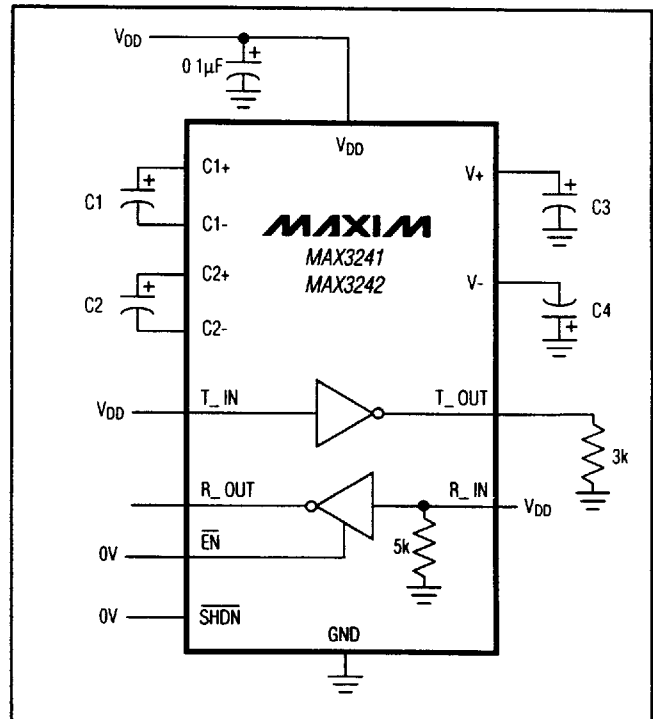

Call toll free 1-800-998-8800 for free samples or literature.

MAX3241/MAX3242

Low Supply Current, True 3-Driver/5-Receiver RS-232 Transceivers

ABSOLUTE MAXIMUM RATINGS

V _{DD}	-0.3V to +6V	Short-Circuit Duration	
V ₊ (Note 1).....	-0.3V to +7V	T _{OUT}	Continuous
V ₋ (Note 1).....	+0.3V to -7V	Continuous Power Dissipation (T _A = +70°C)	
V ₊ + V ₋ (Note 1)	+13V	Wide SO	1000mW
Input Voltages		SSOP762mW
T _{IN} , $\overline{\text{SHDN}}$, $\overline{\text{EN}}$	-0.3V to +6V	Operating Temperature Range.....	0°C to +70°C
R _{IN}	±25V	Storage Temperature Range.....	-65°C to +150°C
Output Voltages		Lead Temperature (soldering, 10sec).....	+300°C
T _{OUT}	±13.2V		
R _{OUT}	-0.3V to (V _{DD} + 0.3V)		

Note 1: V₊ and V₋ can have a maximum magnitude of 7V, but their absolute difference cannot exceed 13V

Stresses beyond those listed under "Absolute Maximum Ratings" may cause permanent damage to the device. These are stress ratings only, and functional operation of the device at these or any other conditions beyond those indicated in the operational sections of the specifications is not implied. Exposure to absolute maximum rating conditions for extended periods may affect device reliability.

ELECTRICAL CHARACTERISTICS

(V_{DD} = 3.0V to 5.5V; C1–C4 = 0.1μF for MAX3241, C1–C4 = 1.0μF for MAX3242 (Note 2); T_A = T_{MIN} to T_{MAX}; unless otherwise noted. Typical values are at T_A = +25°C.)

PARAMETER	CONDITIONS	MIN	TYP	MAX	UNITS
DC CHARACTERISTICS					
V _{DD} Power-Supply Current	No load, V _{CC} = 3.3V or 5.0V, T _A = +25°C	MAX3241	0.3	1.0	mA
		MAX3242	0.1	0.2	
Shutdown Supply Current	Figure 3, T _A = +25°C		1	10	μA
LOGIC					
Input Logic Threshold Low	T _{IN} , $\overline{\text{EN}}$, $\overline{\text{SHDN}}$			0.8	V
Input Logic Threshold High	T _{IN} , $\overline{\text{EN}}$, $\overline{\text{SHDN}}$	V _{DD} = 3.3V	2.0		V
		V _{DD} = 5.0V	2.8		
Input Leakage Current	T _{IN} , $\overline{\text{EN}}$, $\overline{\text{SHDN}}$ = 0V or V _{DD}		0.01	10	μA
Output Leakage Current	$\overline{\text{EN}}$ = V _{DD}		0.05	±10	μA
Output Voltage Low	I _{OUT} = 1.6mA			0.4	V
Output Voltage High	I _{OUT} = -1.0mA	V _{DD} - 0.6V	V _{DD} - 0.1V		V
RECEIVER INPUTS					
Input Voltage Range		-25		+25	V
Input Threshold Low	T _A = +25°C	V _{DD} = 3.3V	0.8	1.2	V
		V _{DD} = 5.0V	0.8	1.5	
Input Threshold High	T _A = +25°C	V _{DD} = 3.3V	1.7	2.4	V
		V _{DD} = 5.0V	1.5	2.4	
Input Hysteresis	No hysteresis when $\overline{\text{SHDN}}$ = 0V		0.1		V
Input Resistance	T _A = +25°C	3	5	7	kΩ

Low Supply Current, True 3-Driver/5-Receiver RS-232 Transceivers

MAX3241/MAX3242

ELECTRICAL CHARACTERISTICS (continued)

($V_{DD} = 3.0V$ to $5.5V$; $C1-C4 = 0.1\mu F$ for MAX3241, $C1-C4 = 1.0\mu F$ for MAX3242 (Note 2); $T_A = T_{MIN}$ to T_{MAX} , unless otherwise noted. Typical values are at $T_A = +25^\circ C$.)

PARAMETER	CONDITIONS	MIN	TYP	MAX	UNITS	
TRANSMITTER OUTPUTS						
Output Voltage Swing	All transmitter outputs loaded with $3k\Omega$ to ground	± 5.0	± 5.4		V	
Output Resistance	$V_{DD} = V_+ = V_- = 0V$, $V_{OUT} = \pm 2V$	300	TBD		Ω	
Output Short-Circuit Current			± 35	± 50	mA	
Output Leakage Current	$V_{OUT} = \pm 12V$, $V_{DD} = 0V$ or $3.0V$ to $5.5V$, $\overline{SHDN} = 0V$			± 10	μA	
MOUSE DRIVEABILITY						
Transmitter Output Voltage	$T1IN = T2IN = GND$, $T3IN = V_{DD}$, $T3OUT$ loaded with $-5mA$, $T1OUT$ and $T2OUT$ loaded with $5mA$	± 5			V	
TIMING CHARACTERISTICS						
Maximum Data Rate	$R_L = 3k\Omega$, $C_L = 1000pF$, one transmitter switching	120			kbps	
Receiver Propagation Delay	Receiver IN to receiver OUT, $C_L = 150pF$	$\overline{R_OUT}$	tPHL	0.5	10	μs
			tPLH	0.5	10	
		R_OUT	tPHL	0.5	10	
			tPLH	0.5	10	
Receiver Output Enable Time	Normal operation	MAX3241	TBD		ns	
		MAX3242	TBD			
Receiver Output Disable Time	Normal operation	MAX3241	TBD		ns	
		MAX3242	TBD			
Transmitter Skew	tPHL - tPLH		TBD		ns	
Receiver Skew	tPHL - tPLH		TBD		ns	
Transition-Region Slew Rate	$V_{CC} = 3.3V$, $R_L = 3k\Omega$ to $7k\Omega$, $C_L = 50pF$ to $2500pF$, measured from $+3V$ to $-3V$ or $-3V$ to $+3V$, Figure 1	4	5.5	30	V/ μs	

Note 2: $C1-C4 = 0.1\mu F$, MAX3241 tested at $3.3V \pm 10\%$.
 $C1-C4 = 1.0\mu F$, MAX3242 tested at $3.3V \pm 10\%$.
 $C1 = 0.047\mu F$, $C2-C4 = 0.33\mu F$, MAX3241 tested at $5.0V \pm 10\%$.
 $C1 = 0.1\mu F$, $C2-C4 = 1.0\mu F$, MAX3242 tested at $5.0V \pm 10\%$.