

トランジスタ・モジュール (NPN, ダーリントン接続, 2個直列接続)

- ダーリントン・トランジスタを2個直列接続
- フリーホイール・ダイオード付
- 電極と金属ケース部分が絶縁されている
- 直流電流増幅率は80以上(定格電流にて)

■等価回路

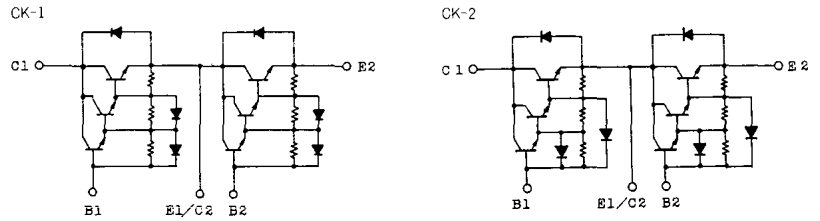

注1.  $T_c=25^\circ\text{C}$ . 注2. A.C. 1分間

型名	最大定格 ( $T_a=25^\circ\text{C}$ )											電気的特性									
	$V_{CE0}$	$V_{CEX(SUS)}$	$V_{EBO}$	$I_c$	$I_{CP}$	$I_B$	$I_F$	$I_{FM}$	$P_c$	$T_j$	$T_{stg}$	$V_{Isc}$	$I_{CBO}$	$I_{EBO}$	$V_{CE0(SUS)}$	$h_{FE}$	$V_{CE}$	$I_c$			
	(V)	(V)	(V)	(A)	(A)	(A)	(A)	(A)	(W)	( $^\circ\text{C}$ )	( $^\circ\text{C}$ )	(V)	(mA)	(mA)	(V)	(A)	(V)	(A)			
MG15N2CK1	1100	1100	7	15	30	1.5	15	30	150	150	-40~125	2500	1.0	1100	200	7	900	1.0	100	5	15
MG15N2YK1	1100	1100	7	15	30	1.5	15	30	150	150	-40~125	2500	1.0	1100	200	7	900	1.0	100	5	15
MG25M2CK2	1000	1000	7	25	50	2.5	25	50	300	150	-40~125	2500	1.0	1000	200	7	880	1.0	100	5	25
MG25M2YK1	1000	1000	7	25	50	2.5	25	50	300	150	-40~125	2500	1.0	1000	200	7	880	1.0	100	5	25
MG25M2YK9	1000	1000	7	25	50	2.5	25	50	300	150	-40~125	2500	1.0	1000	200	7	880	1.0	100	5	25
MG25N2CK1	1100	1100	7	25	50	2.5	25	50	300	150	-40~125	2500	1.0	1100	200	7	900	0.5	100	5	25
MG25N2YK1	1100	1100	7	25	50	2.5	25	50	300	150	-40~125	2500	1.0	1100	200	7	900	0.5	100	5	25
MG30G2CL3	600	600	6	30	60	3.0	30	60	250	150	-40~125	2500	1.0	600	200	6	450	0.5	100	5	30
MG30G2YL1	600	600	6	30	60	3.0	30	60	200	150	-40~125	2500	1.0	600	200	6	450	0.5	100	5	30
MG40S2YK1	1400	1400	7	40	80	4.0	40	80	400	150	-40~125	2500	2.0	1400	150	7	1000	1.0	100	5	40
MG50G2CL3	600	600	6	50	100	5.0	50	100	300	150	-40~125	2500	1.0	600	200	6	450	0.5	100	5	50
MG50G2YL1A	600	600	6	50	100	5.0	50	100	300	150	-40~125	2500	1.0	600	200	6	450	0.5	100	5	50
MG50M2CK2	1000	1000	7	50	100	5.0	50	100	350	150	-40~125	2500	1.0	1000	200	7	880	1.0	100	5	50
MG50M2YK1	1000	1000	7	50	100	5.0	50	100	350	150	-40~125	2500	1.0	1000	200	7	880	1.0	100	5	50
MG50M2YK9	1000	1000	7	50	100	5.0	50	100	350	150	-40~125	2500	1.0	1000	200	7	880	1.0	100	5	50
MG50N2CK1	1100	1100	7	50	100	5.0	50	100	350	150	-40~125	2500	1.0	1100	200	7	900	1.0	100	5	50
MG50Q2YK1	1200	1200	7	50	100	5.0	50	100	350	150	-40~125	2500	1.0	1200	200	7	900	1.0	100	5	50
MG75G2CL1	600	600	6	75	150	10	75	150	350	150	-40~125	2500	1.0	600	200	6	450	0.5	80	5	75
MG75G2YL1A	600	600	6	75	150	10	75	150	350	150	-40~125	2500	1.0	600	200	6	450	0.5	80	5	75
MG75H2CL1	600	600	6	75	150	10	75	150	350	150	-40~125	2500	1.0	600	200	6	500	0.5	80	5	75
MG75H2YL1A	600	600	6	75	150	10	75	150	350	150	-40~125	2500	1.0	600	200	6	500	0.5	80	5	75

<http://store.iicc/>

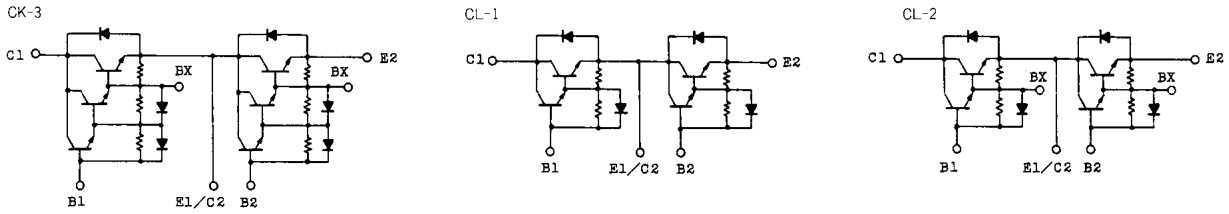

注3. スイッチング時間の \* 印はtyp.値。

(T <sub>a</sub> =25°C)										エミッタ・コレクタ間ダイオード						熱抵抗		等価回路	外形図	記事	型名	
飽和電圧 (V)		I <sub>c</sub> (A)	I <sub>B</sub> (A)	スイッチング時間 (μs)			I <sub>B1</sub> (A)	I <sub>B2</sub> (A)	V <sub>CC</sub> (V)	R <sub>L</sub> (Ω)	V <sub>F</sub> (V)	t <sub>rr</sub> (μs)		I <sub>F</sub> (A)	V <sub>BE</sub> (V)	di/dt (A/μs)	R <sub>th(j-c)</sub> (°C/W)					
V <sub>CE</sub> 最大	V <sub>BE</sub> 最大			t <sub>on</sub> 最大	t <sub>sto</sub> 最大	t <sub>f</sub> 最大						トランジスタ部	ダイオード部				最大					最大
2.5	3.5	15	0.3	2	11	6	0.3	-0.9	600	40	1.5	15	1.0	15	-3	60	0.83	1.3	CK-2	2-68B2A		MG15N2CK1
2.5	3.5	15	0.3	2	11	6	0.3	-0.9	600	40	1.5	15	1.0	15	-3	60	0.83	1.3	YK-1	2-94C3A		MG15N2YK1
2.5	3.5	25	0.5	2	15	5	0.5	-0.5	600	24	1.7	25	1.0	25	-3	100	0.41	1.3	CK-2	2-68B2A		MG25M2CK2
2.5	3.5	25	0.5	2	15	5	0.5	-0.5	600	24	1.7	25	1.0	25	-3	100	0.41	1.3	YK-1	2-94C3A		MG25M2YK1
2.5	3.5	25	0.5	2	15	5	0.5	-0.5	600	24	1.7	25	1.0	25	-3	100	0.41	1.3	YK-1	2-94D1A		MG25M2YK9
2.5	3.5	25	0.5	2	14	6	0.5	-1.5	600	24	1.7	25	1.0	25	-3	100	0.41	1.3	CK-2	2-68B2A		MG25N2CK1
2.5	3.5	25	0.5	2	14	6	0.5	-1.5	600	24	1.7	25	1.0	25	-3	100	0.41	1.3	YK-1	2-94C3A		MG25N2YK1
2.0	2.5	30	0.6	1	12	2	0.6	-0.6	300	10	1.5	30	1.0	30	-3	100	0.5	1.8	CL-1	2-68A2A		MG30G2CL3
2.0	2.5	30	1.0	1	12	3	0.6	-0.6	300	10	1.6	30	1.0	30	-2	60	0.625	1.8	YL-1	2-94C3A		MG30G2YL1
2.5	3.5	40	0.8	2	17	3	0.8	-2.4	600	15	1.8	40	1.2	40	-3	100	0.31	1.3	YK-1	2-108A2A		MG40S2YK1
2.0	2.5	50	1.0	1	12	2	1.0	-1.0	300	6	1.5	50	1.0	50	-3	100	0.41	1.3	CL-1	2-68A2A		MG50G2CL3
2.0	2.5	50	1.0	1	12	2	1.0	-1.0	300	6	1.7	50	1.0	50	-3	100	0.41	1.3	YL-1	2-94C3A		MG50G2YL1A
2.5	3.5	50	1.0	2	15	5	1.0	-1.0	600	12	1.7	50	1.0	50	-3	100	0.36	1.3	CK-2	2-68B2A		MG50M2CK2
2.5	3.5	50	1.0	2	15	5	1.0	-1.0	600	12	1.7	50	1.0	50	-3	100	0.36	1.3	YK-1	2-94C3A		MG50M2YK1
2.5	3.5	50	1.0	2	15	5	1.0	-1.0	600	12	1.7	50	1.0	50	-3	100	0.36	1.3	YK-1	2-94D1A		MG50M2YK9
2.5	3.5	50	1.0	2	15	5	1.0	-3.0	600	12	1.8	50	2.0	50	-3	100	0.35	1.3	CK-2	2-68B2A		MG50N2CK1
2.5	3.2	50	1.0	2	13	4	1.0	-3.0	600	12	1.8	50	1.0	50	-3	100	0.35	1.3	YK-1	2-94C3A		MG50Q2YK1
2.0	2.5	75	1.5	2	12	2	1.5	-1.5	300	4	1.5	75	2.0	75	-3	100	0.35	1.3	CL-1	2-68A2A		MG75G2CL1
2.0	2.5	75	1.5	2	12	2	1.5	-1.5	300	4	1.7	75	1.0	75	-3	100	0.36	1.3	YL-1	2-94C3A		MG75G2YL1A
2.0	2.5	75	2.0	2	12	4	2.0	-2.0	300	4	1.5	75	2.0	75	-3	100	0.35	1.3	CL-1	2-68A2A		MG75H2CL1
2.0	2.5	75	2.0	2	12	4	2.0	-2.0	300	4	1.7	75	1.0	75	-3	100	0.35	1.3	YL-1	2-94C3A		MG75H2YL1A

<http://store.iicc/>

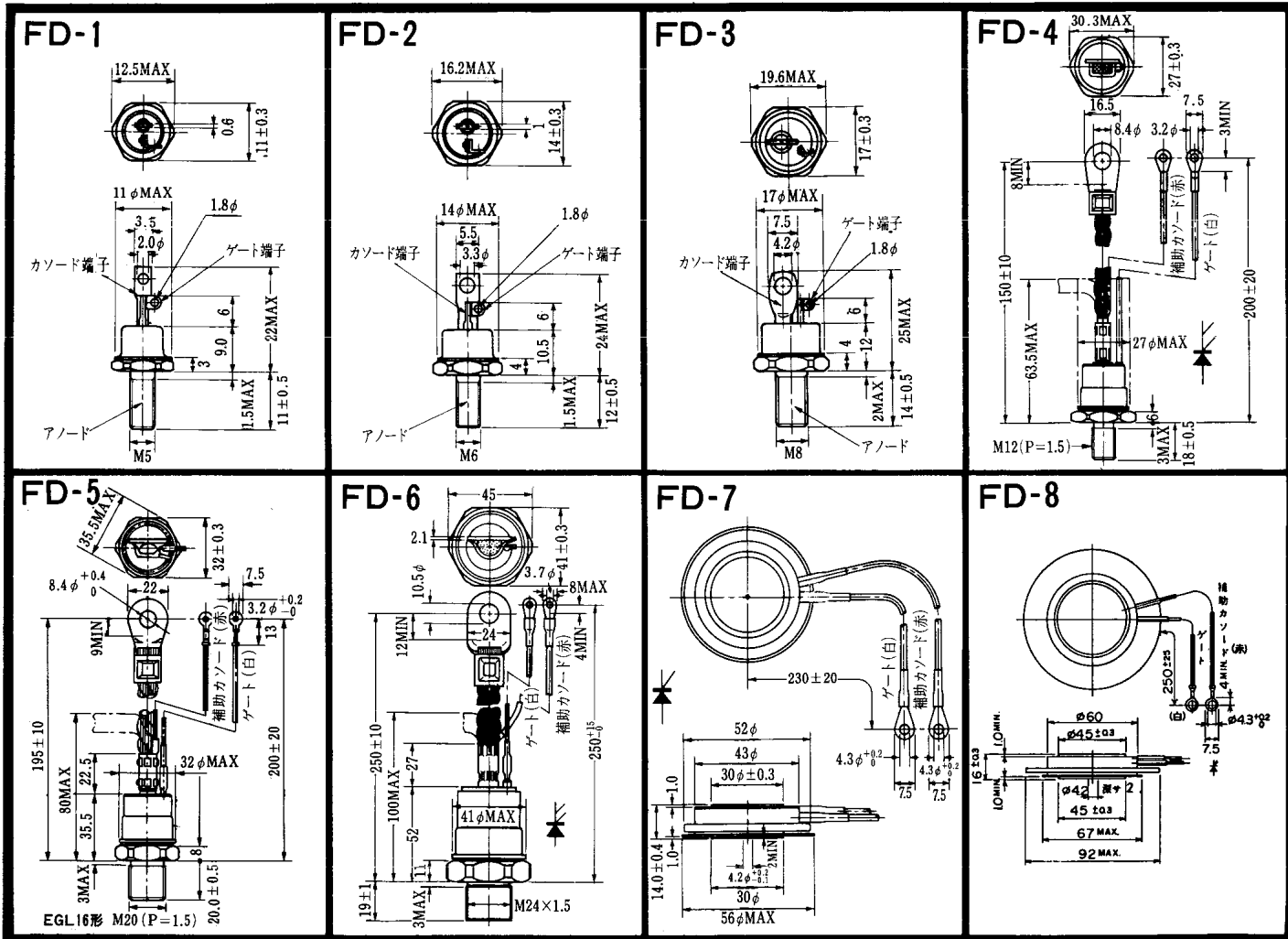

<http://store.iicc.cc/>

〈寸法図単位:mm〉

FD-9

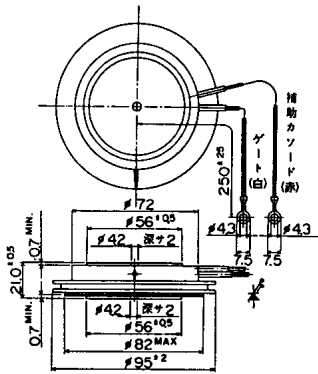

FD-10

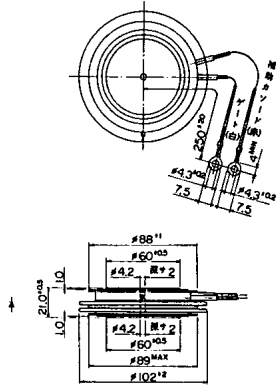

FD-11

FD-12

〈寸法図単位:mm〉

<http://store.iic.cc/>

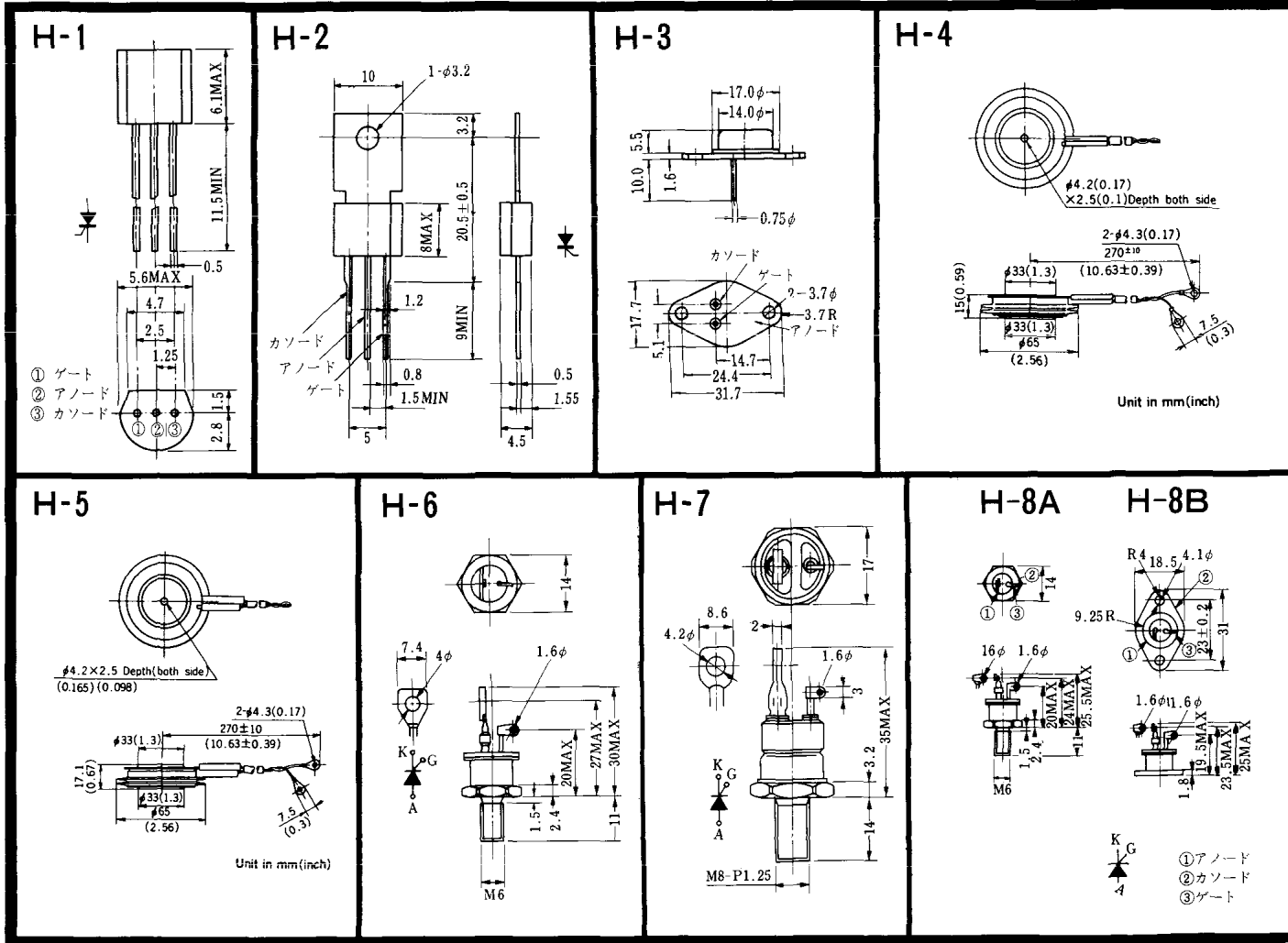

〈寸法図単位：mm〉

<http://store.iic.cc/>



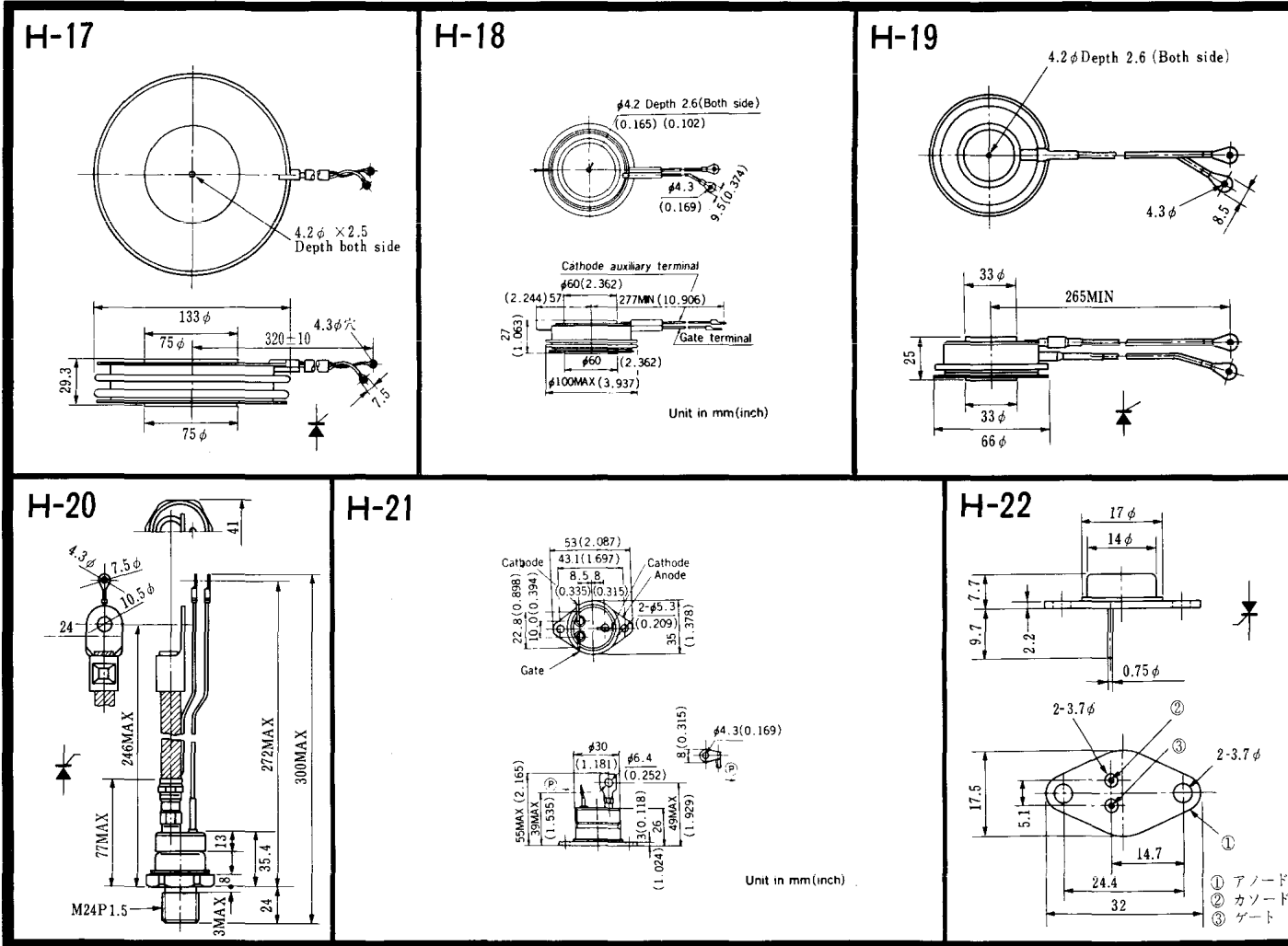

《寸法図単位：mm》

<http://store.iicc.cc/>

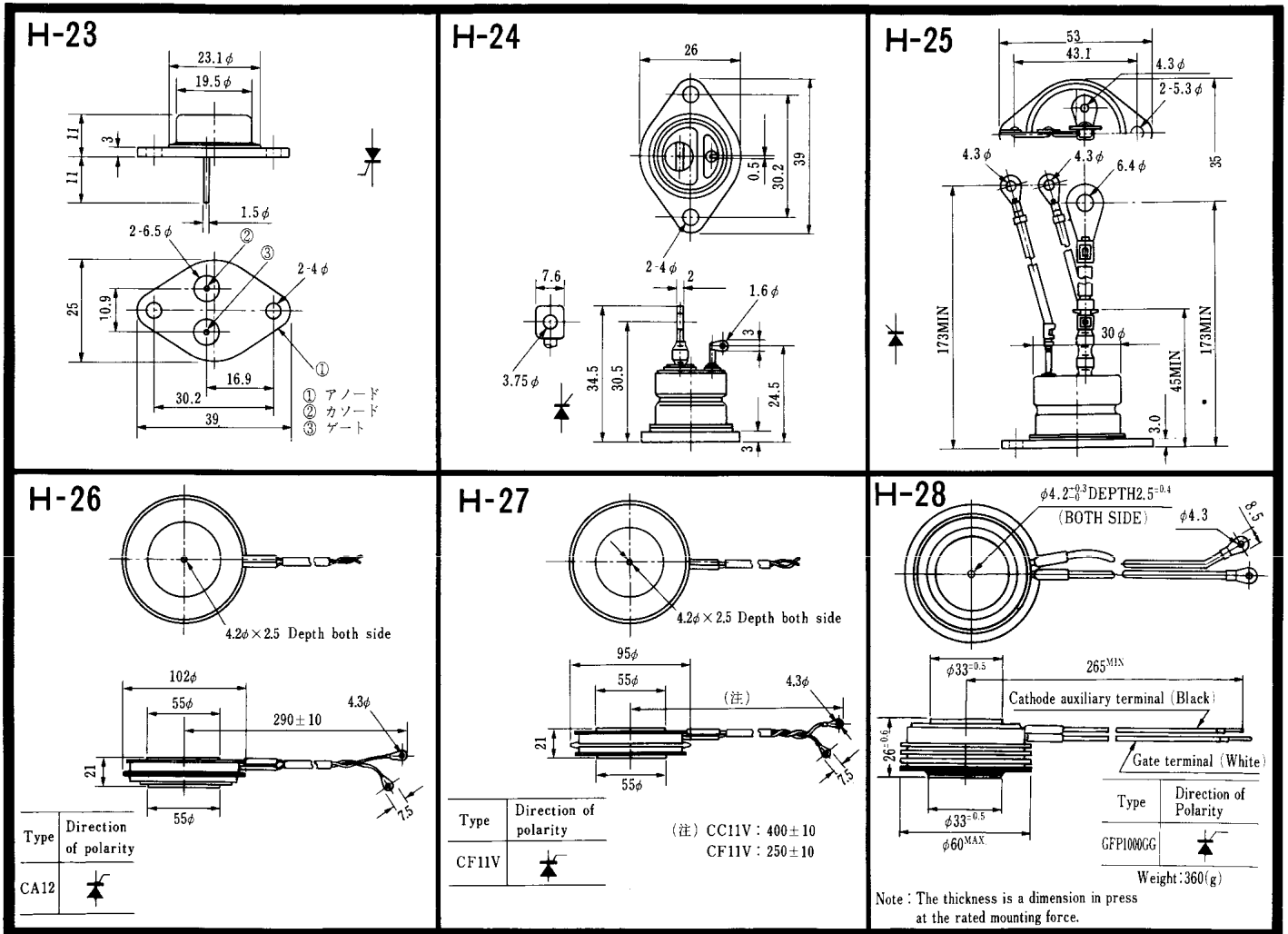

《寸法図単位：mm》

<http://store.iicc.cc/>



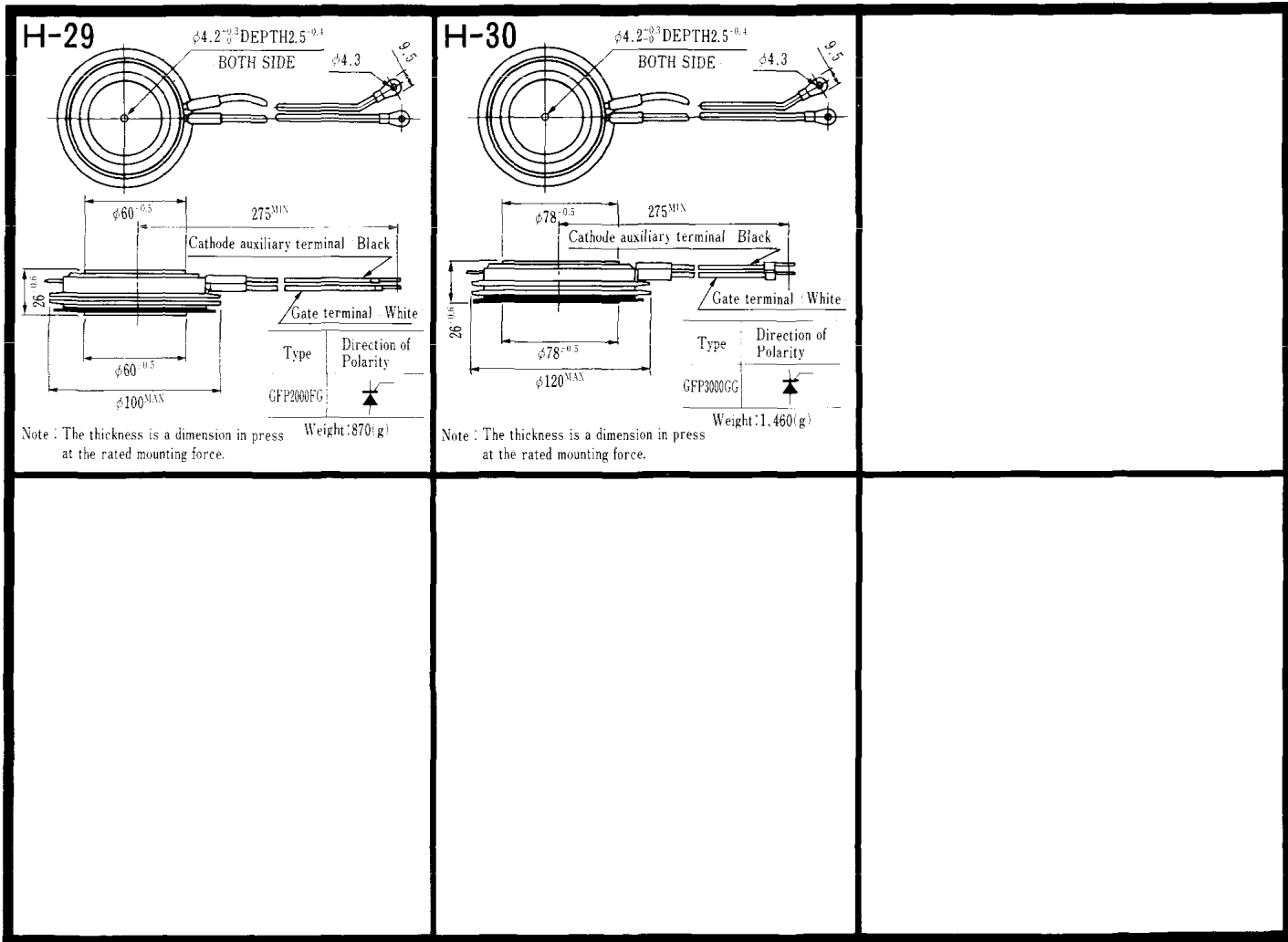

<寸法図単位:mm>

<http://store.iic.cc/>

### HT-1

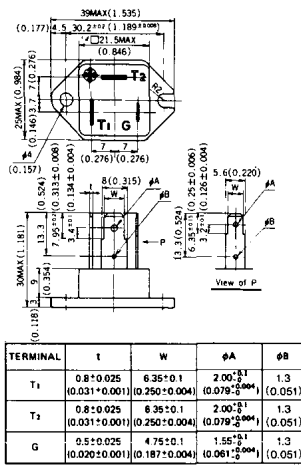

Unit in mm (inch)

### HT-2

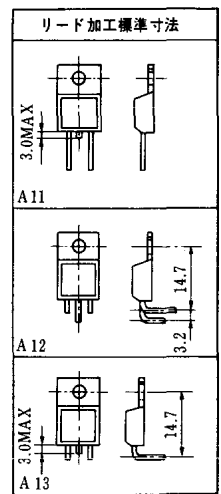
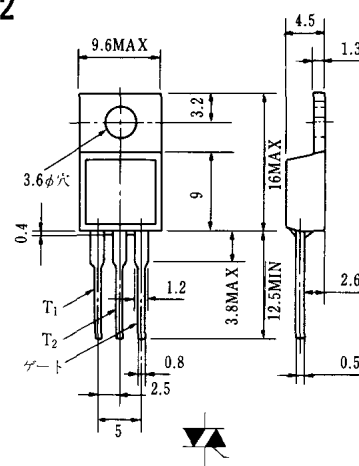

### HT-3

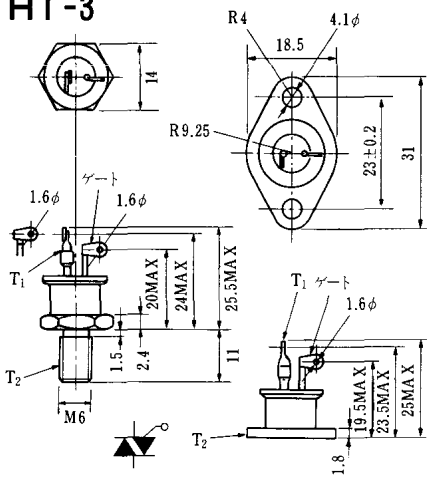

### HT-4

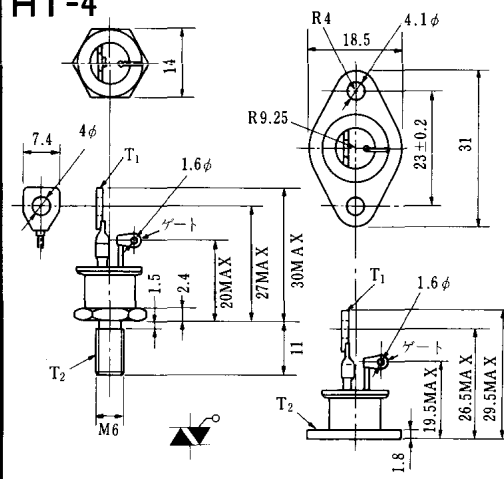

### HT-5

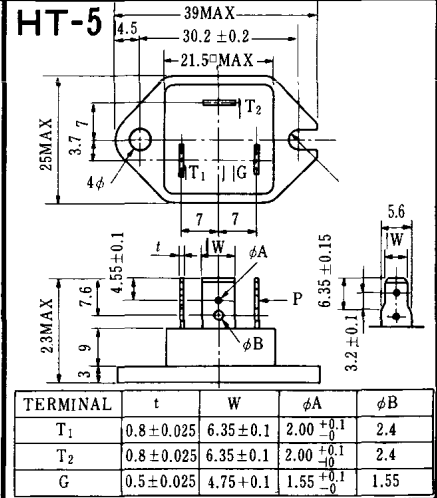

《寸法図単位：mm》

<http://store.iicc/>



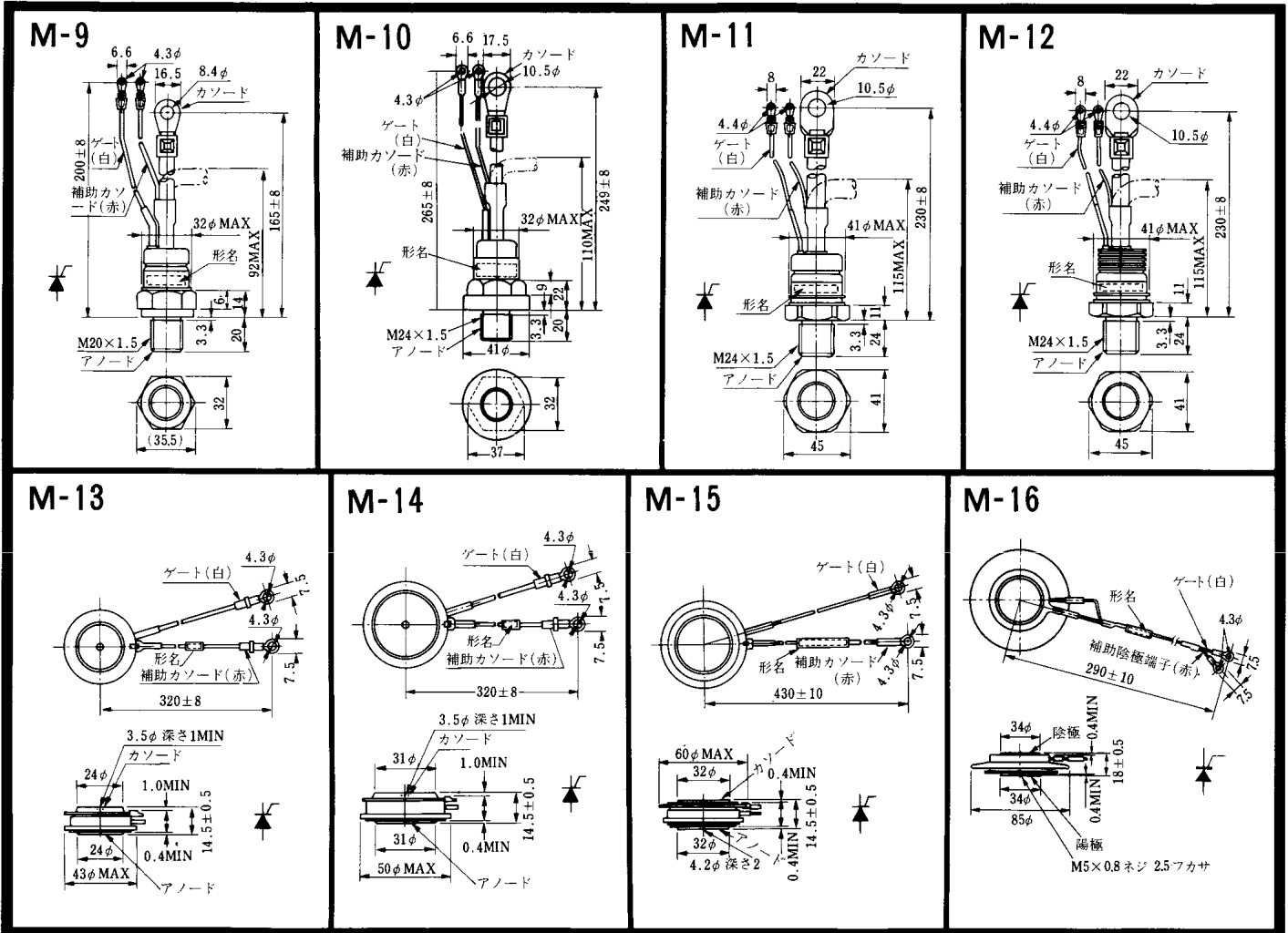

〈寸法図単位：mm〉

<http://store.iicc.cc/>



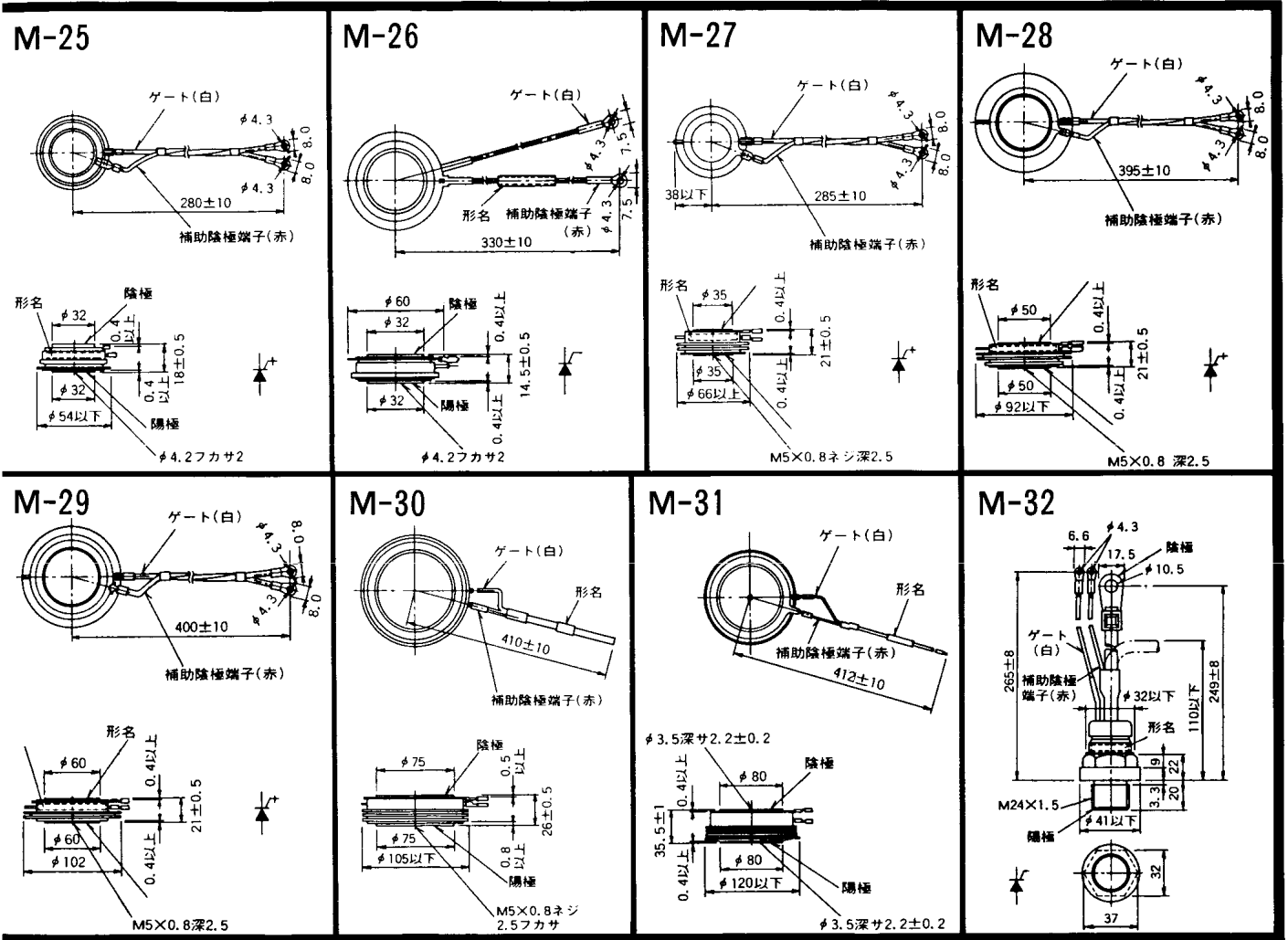

《寸法図単位：mm》

<http://store.iicc/>

<p><b>M-33</b></p>	<p><b>M-34</b></p>		

〈寸法図単位:mm〉

<http://store.iic.cc/>

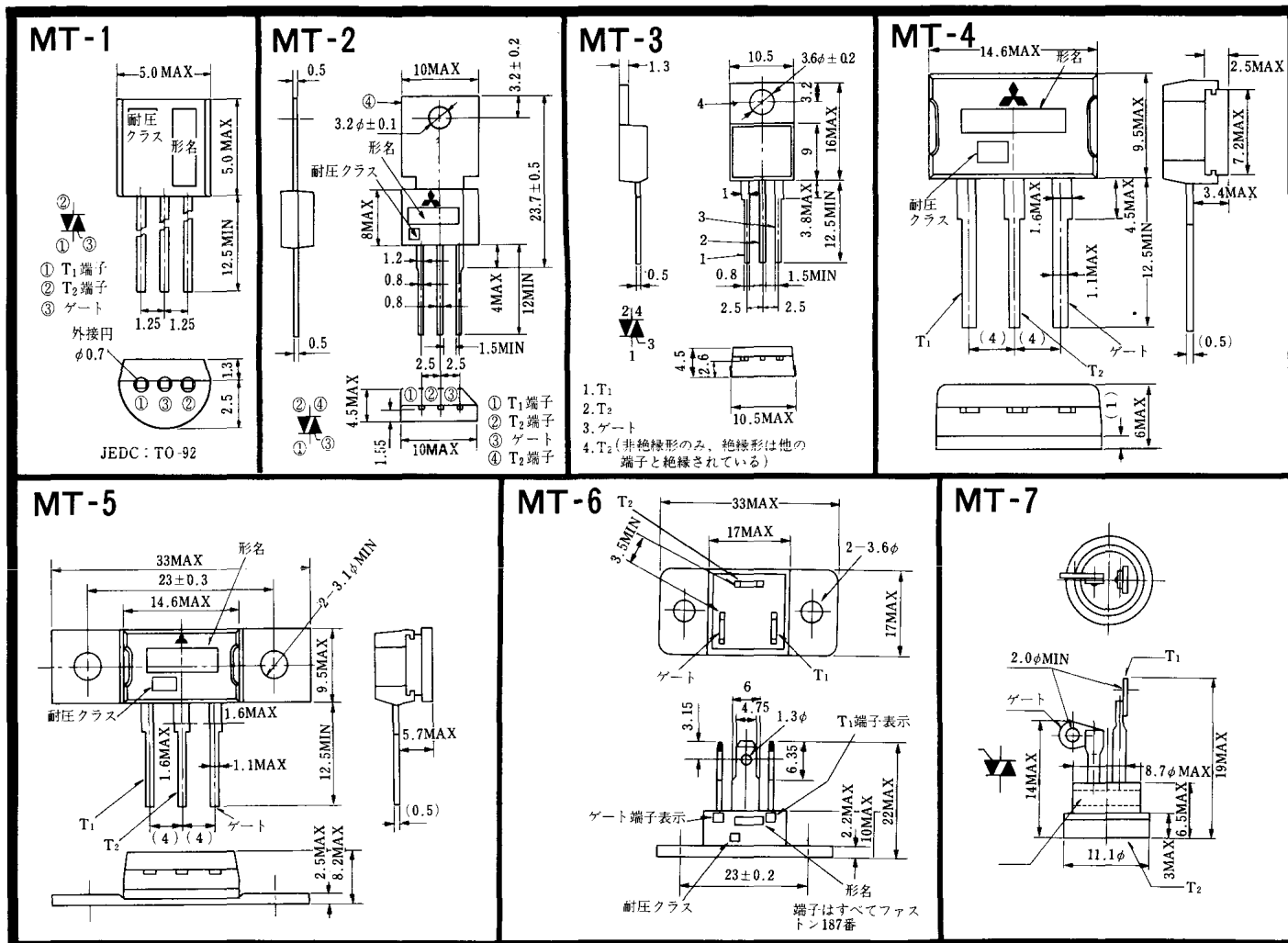

《寸法図単位：mm》

<http://store.iic.cc/>



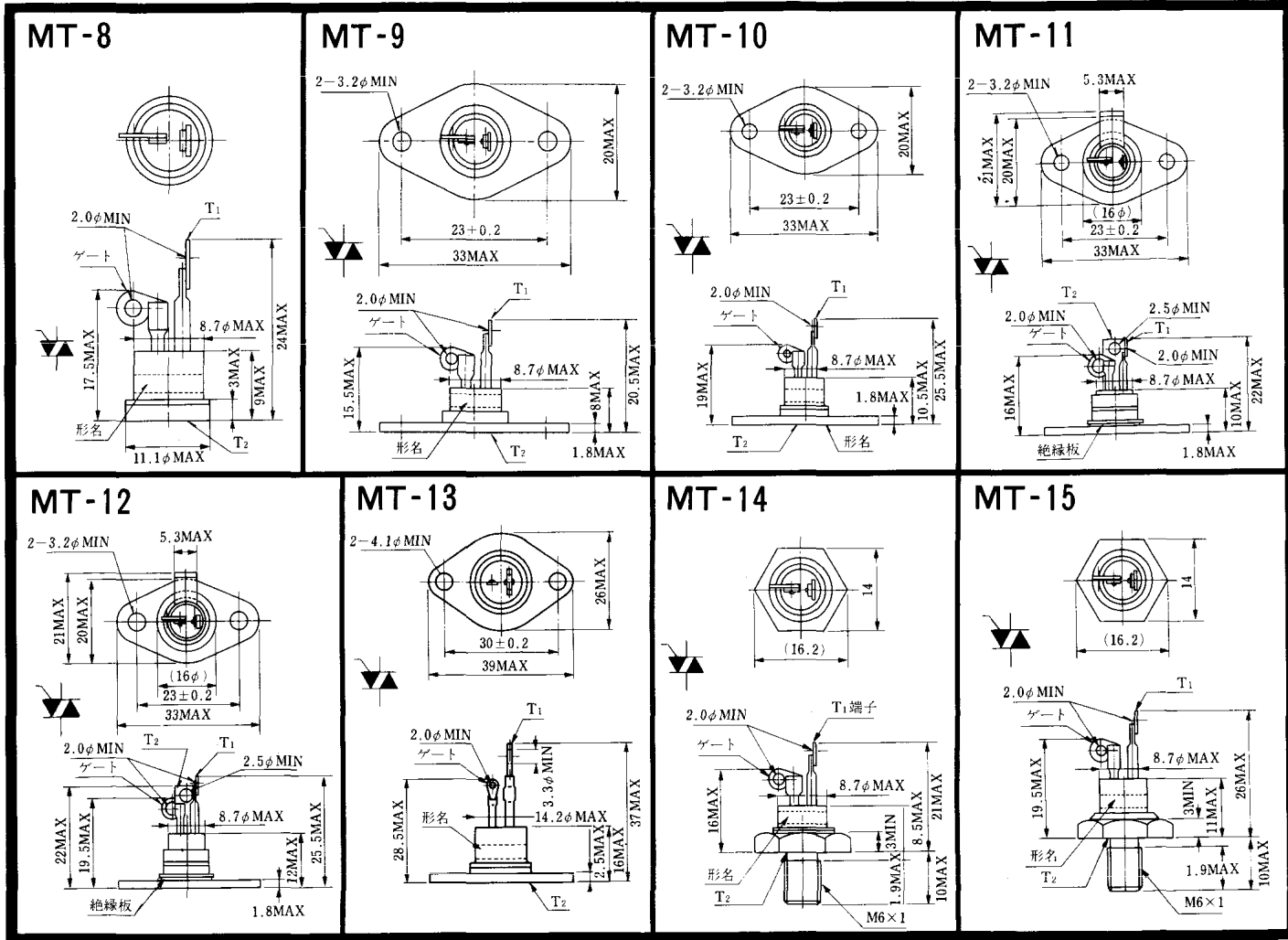

《寸法図単位：mm》

<http://store.iic.cc/>

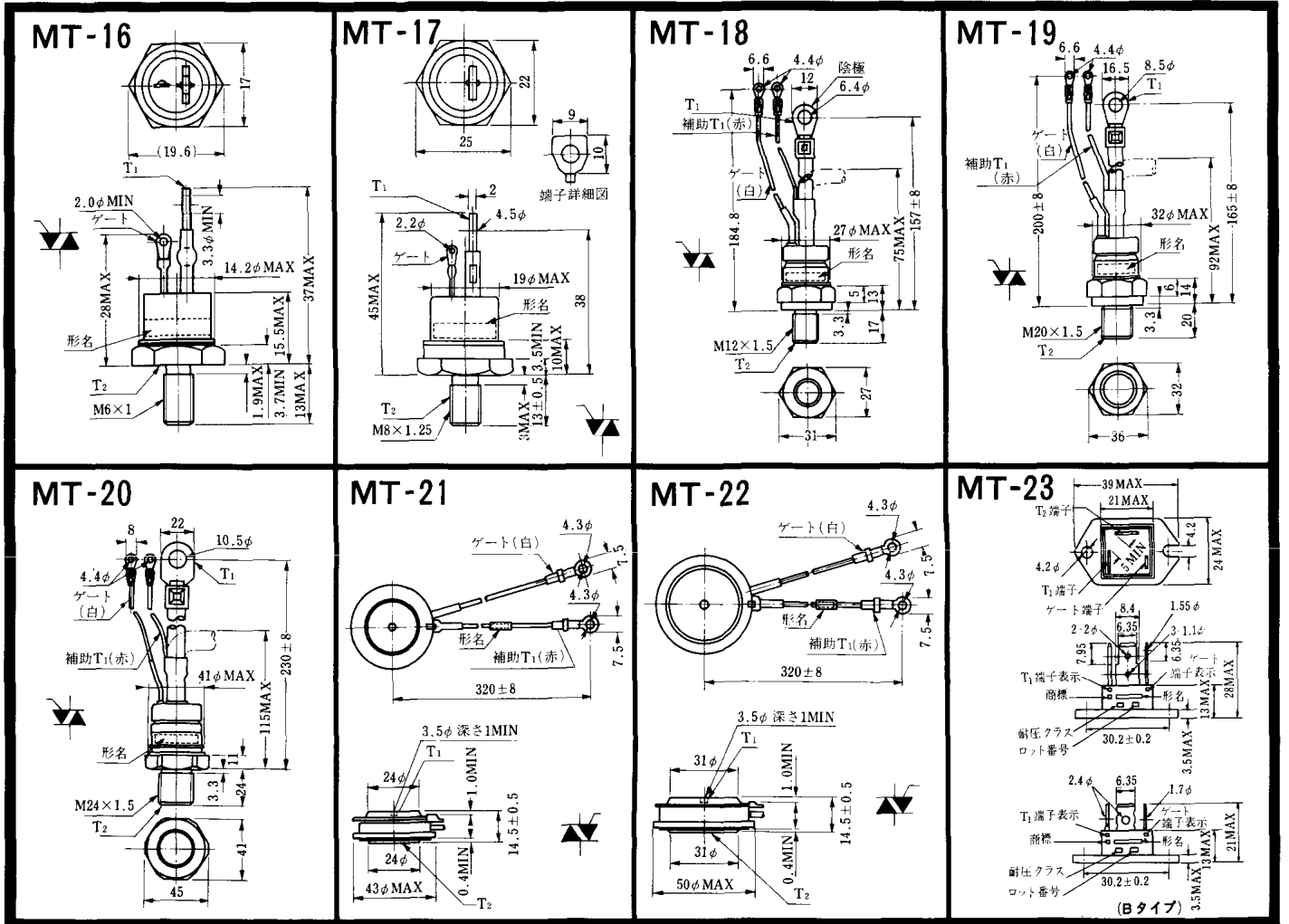

《寸法図単位：mm》

<http://store.iicc/>

<p><b>MT-24</b></p> <p>Technical drawing of the MT-24 component. It includes a side view on the left and a top view on the right. Dimensions are provided in millimeters: side view shows 4.5, 1.5, 0.6, and 2.8; top view shows 15.6, 20.0, 20.0, 2, 1.0, 5.45, 5.45, 1.5, and 1.0. A pinout diagram shows a triangle with pins 1, 2, and 3. A legend identifies the pins: ① T1端子, ② T2端子, ③ ゲート端子, ④ T2端子. The label TO-3P is also present.</p>			

〈寸法図単位:mm〉

<http://store.iic.cc/>

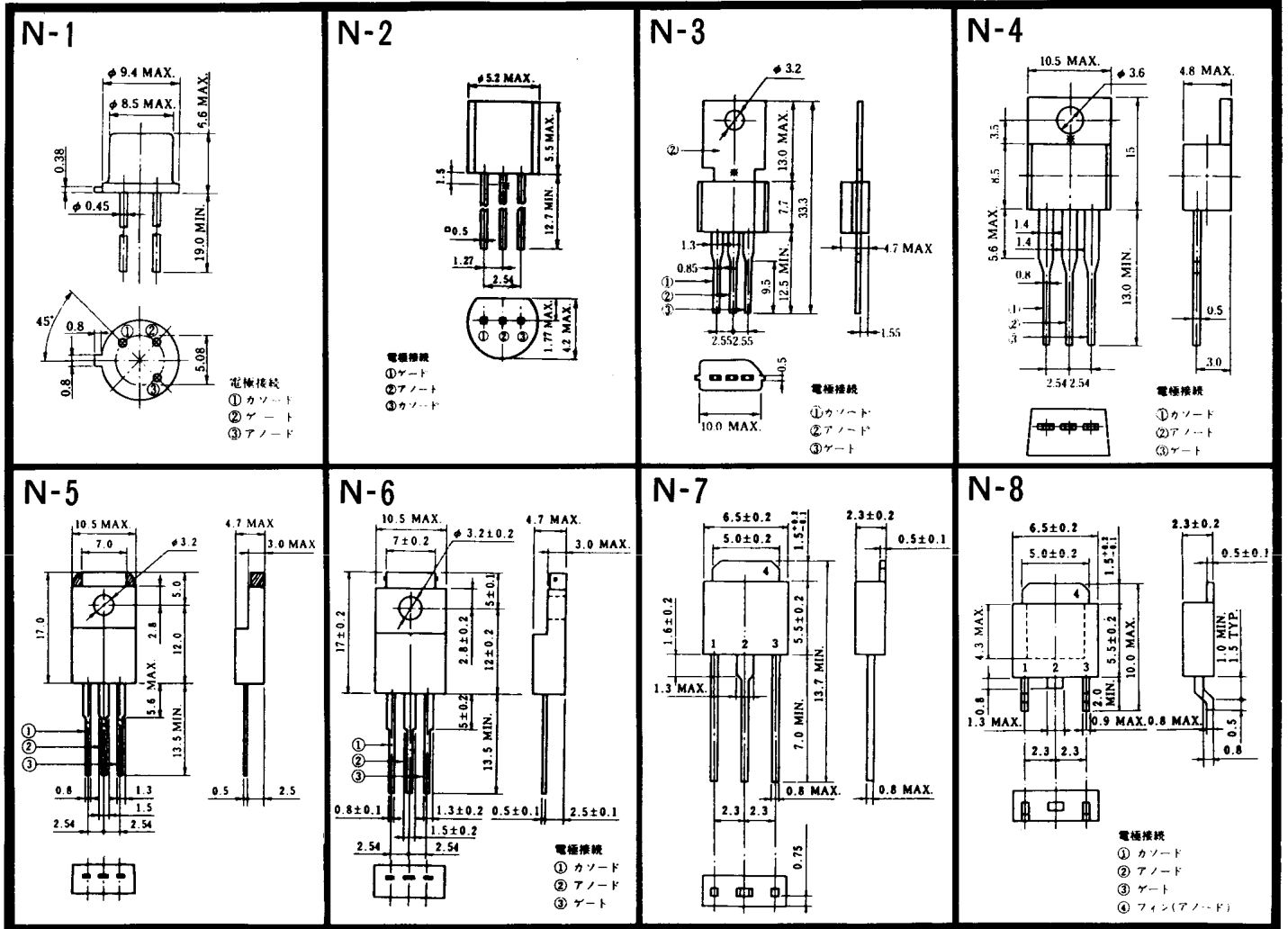

〈寸法図単位:mm〉

<http://store.iicc.cc/>

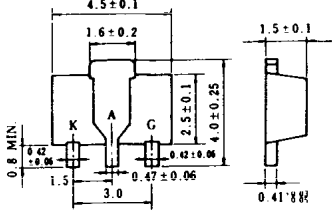
<p><b>N-9</b></p>  <p>電極標記 K: カソード A: アノード G: ゲート</p>			

< 寸法図単位 : mm >

<http://store.iic.cc/>

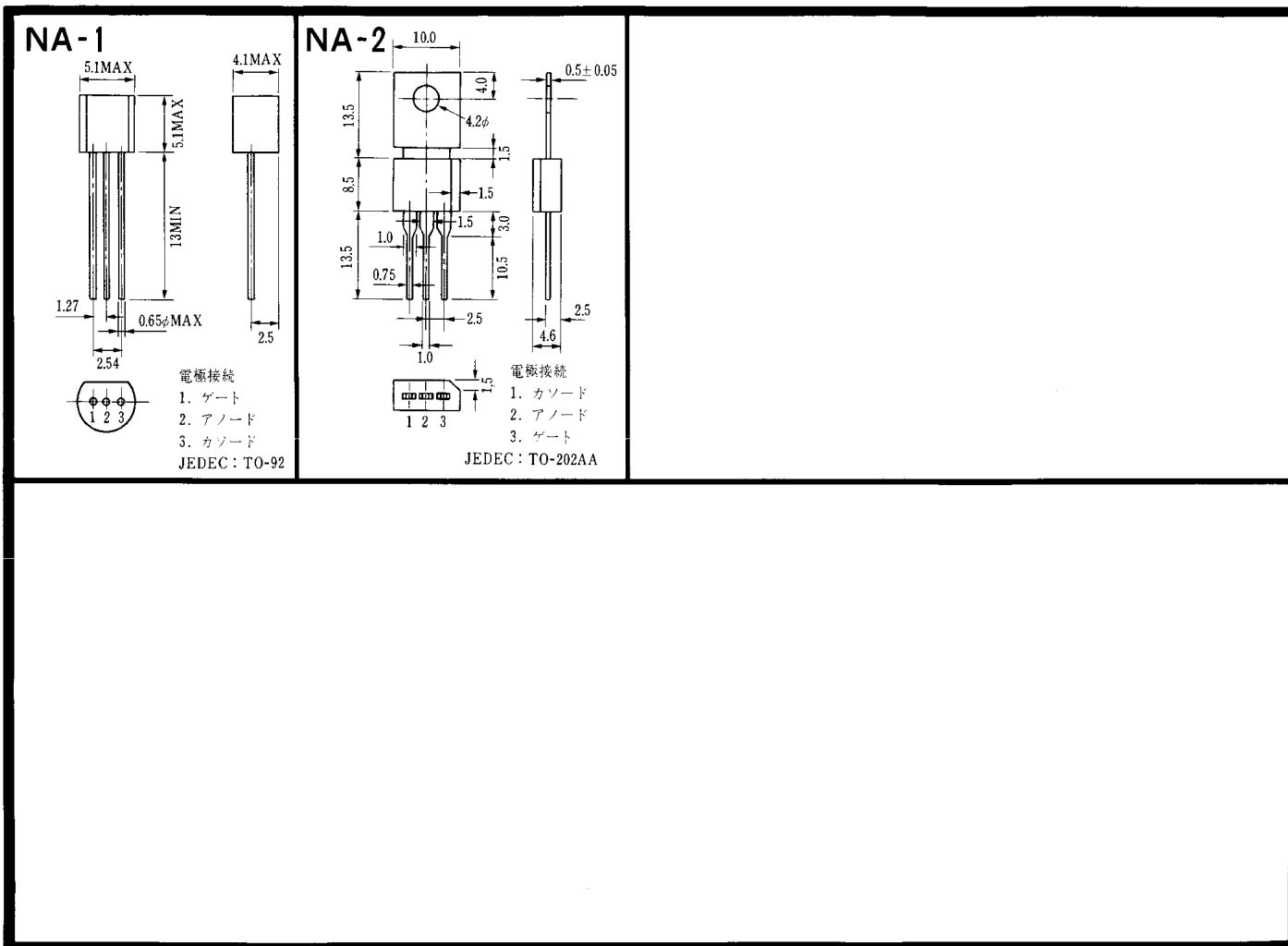

《寸法図単位：mm》

<http://store.iic.cc/>

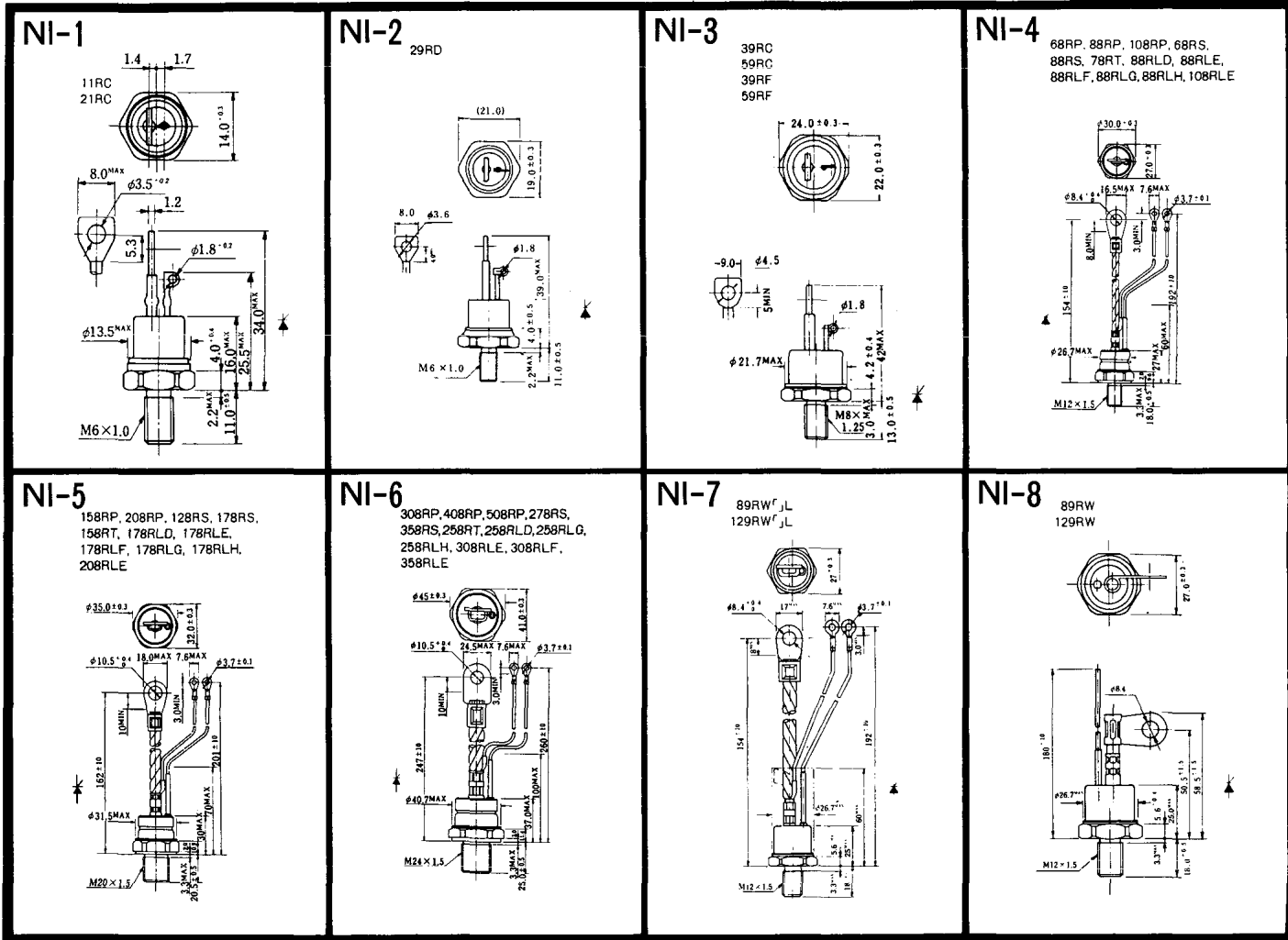

《寸法図単位:mm》

<http://store.iicc/>

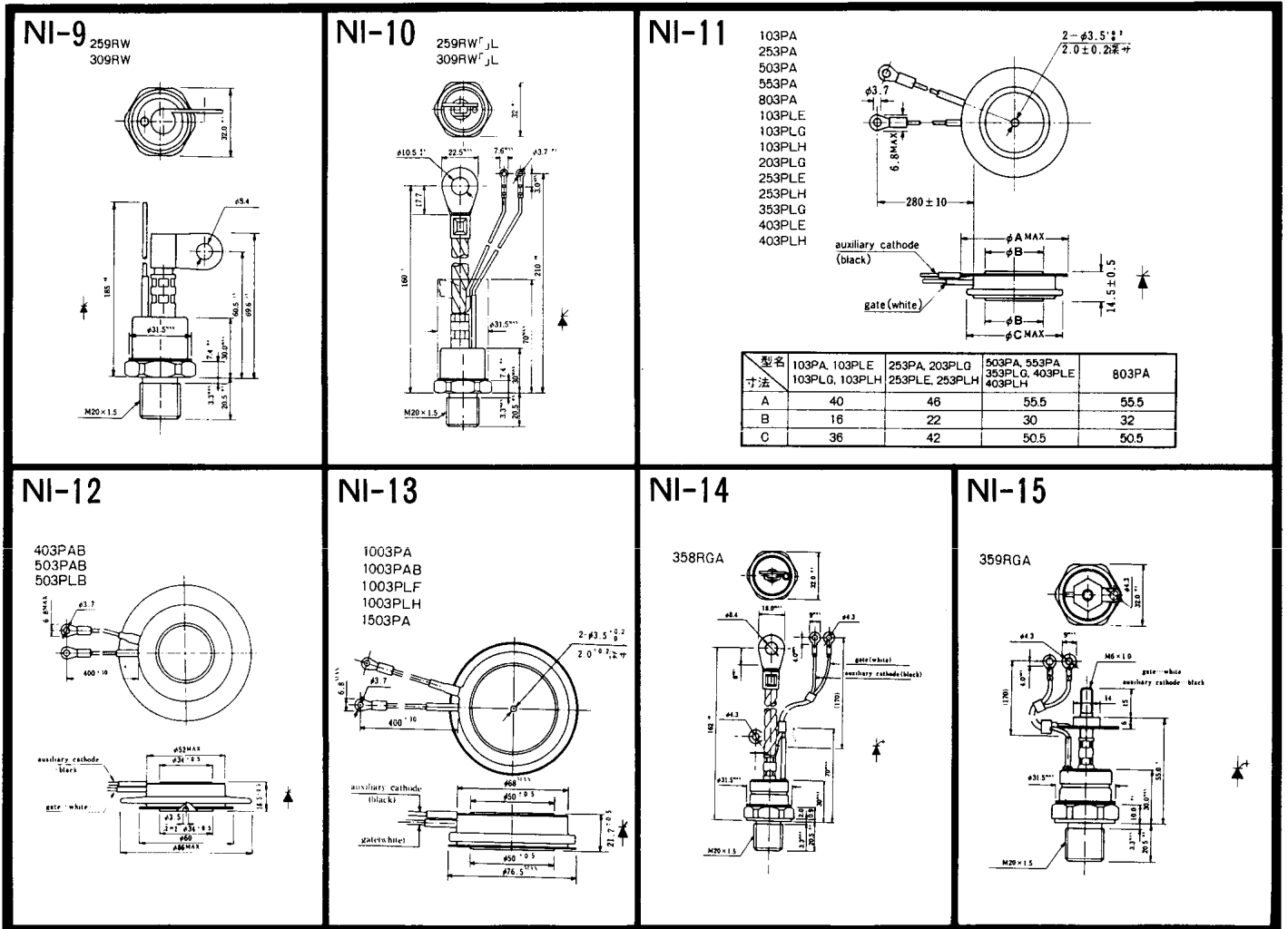

《寸法図単位:mm》

<http://store.iicc.cc/>



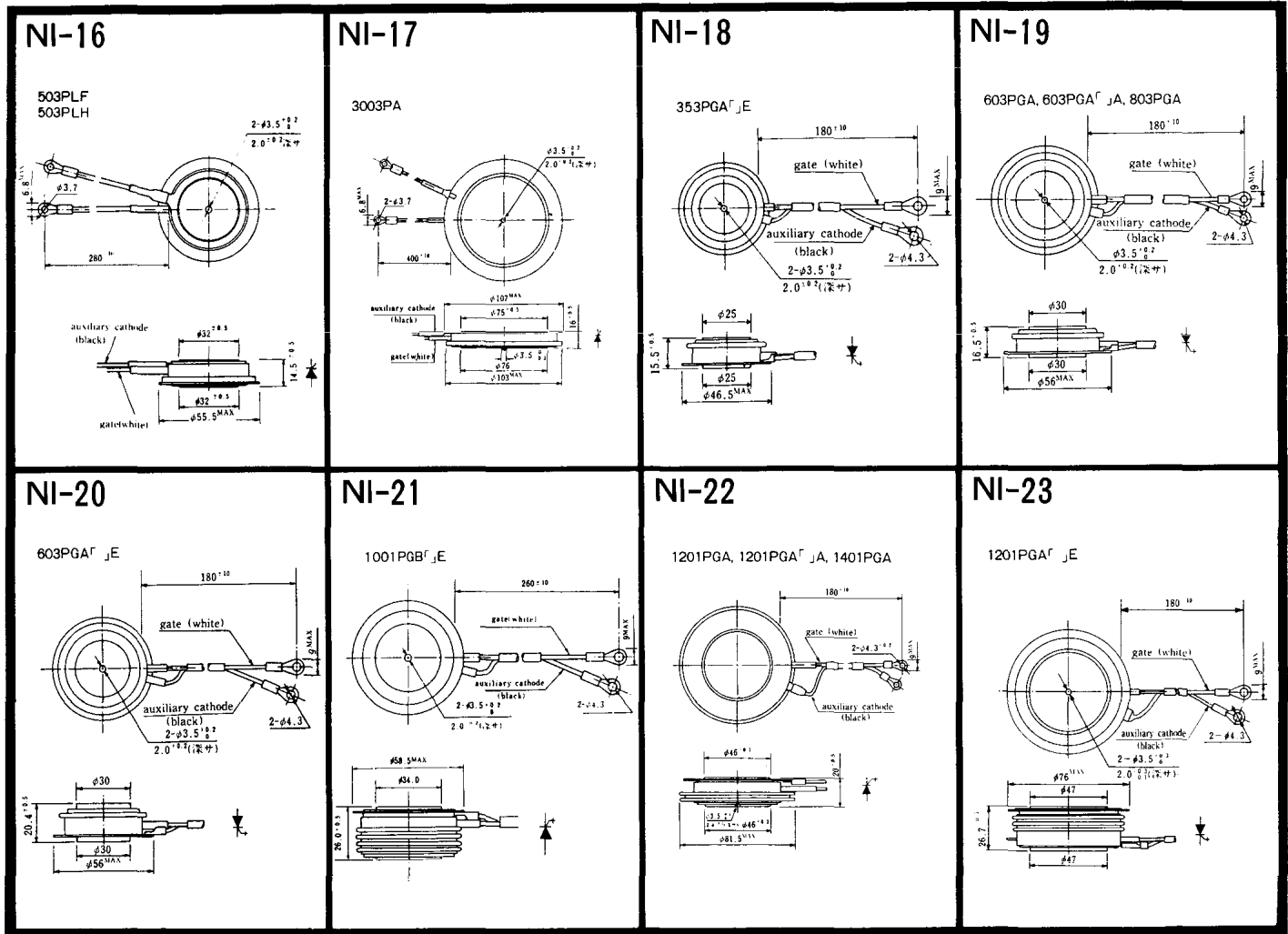

《寸法図単位:mm》

<http://store.iic.cc/>

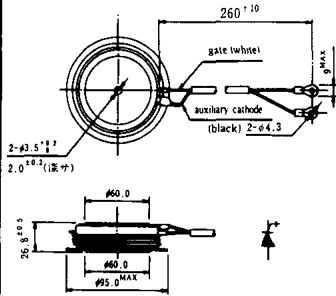
NI-24	NI-25	NI-26	
<p>2001PGBF JE</p>  <p>Technical drawing of a vacuum tube (NI-24) showing top and side views with dimensions and labels. The top view shows a circular base with a diameter of <math>\phi 60.0</math> and a maximum diameter of <math>\phi 95.0</math> MAX. The side view shows a length of <math>26.0 \pm 0.5</math> and a diameter of <math>\phi 60.0</math>. The drawing includes labels for 'gate (white)', 'auxiliary cathode (black) 2-<math>\phi 4.3</math>', and '2-<math>\phi 3.5 \pm 0.1</math> 2.0<sup>±0.2</sup> (深中)'. A dimension of <math>260 \pm 10</math> is also indicated.</p>			

<http://store.iic.cc/>

《寸法图单位:mm》

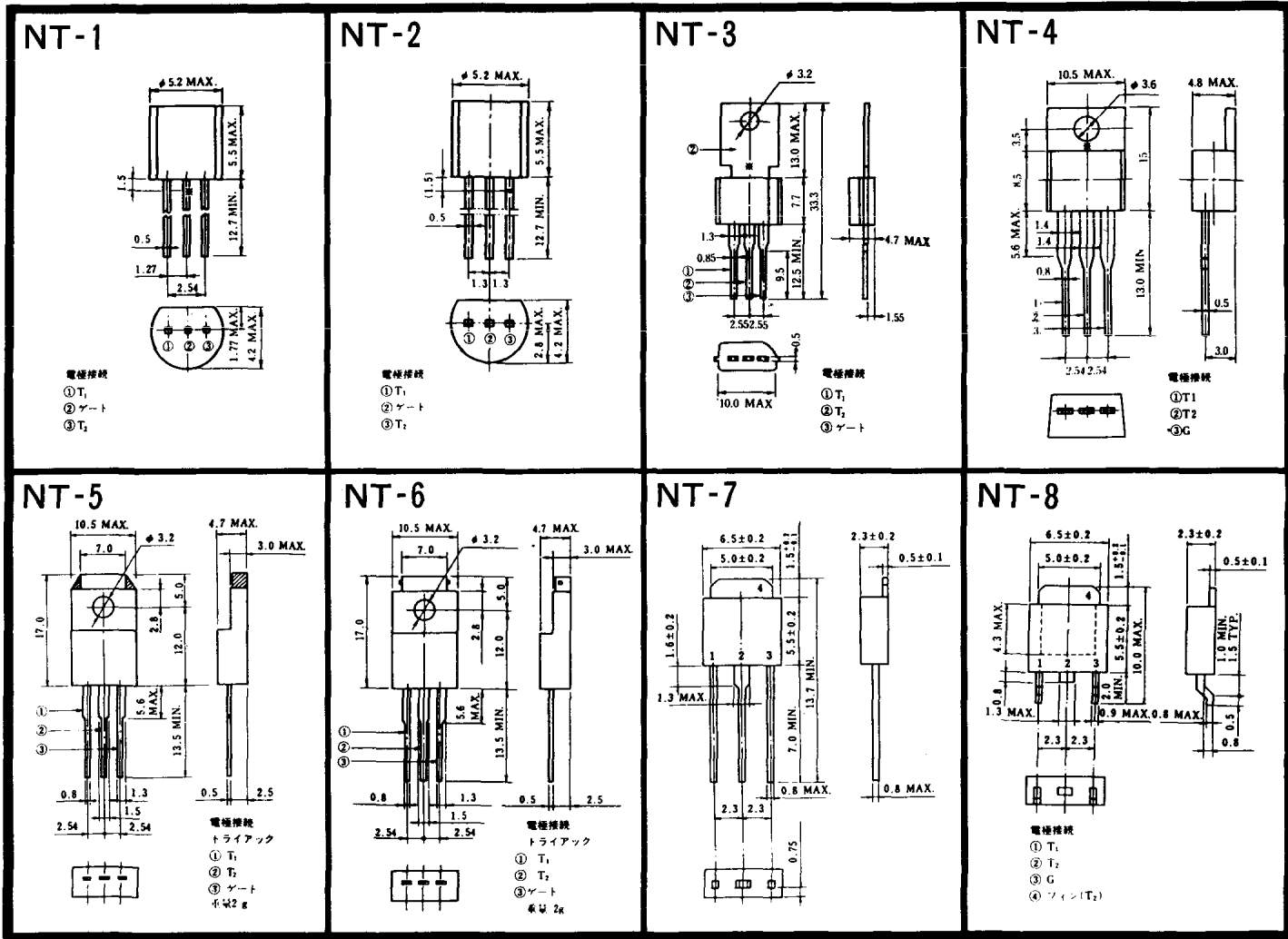

<http://store.iicc/>

〈寸法図単位:mm〉

### S-1

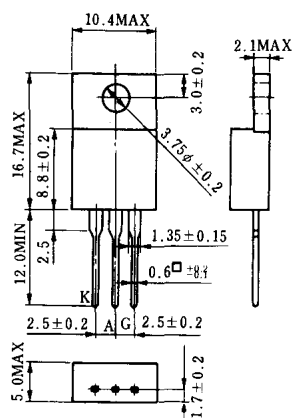

### ST-1

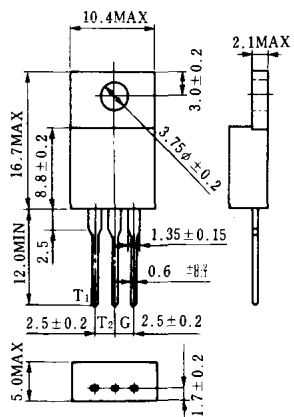

《寸法図単位：mm》

<http://store.iic.cc/>

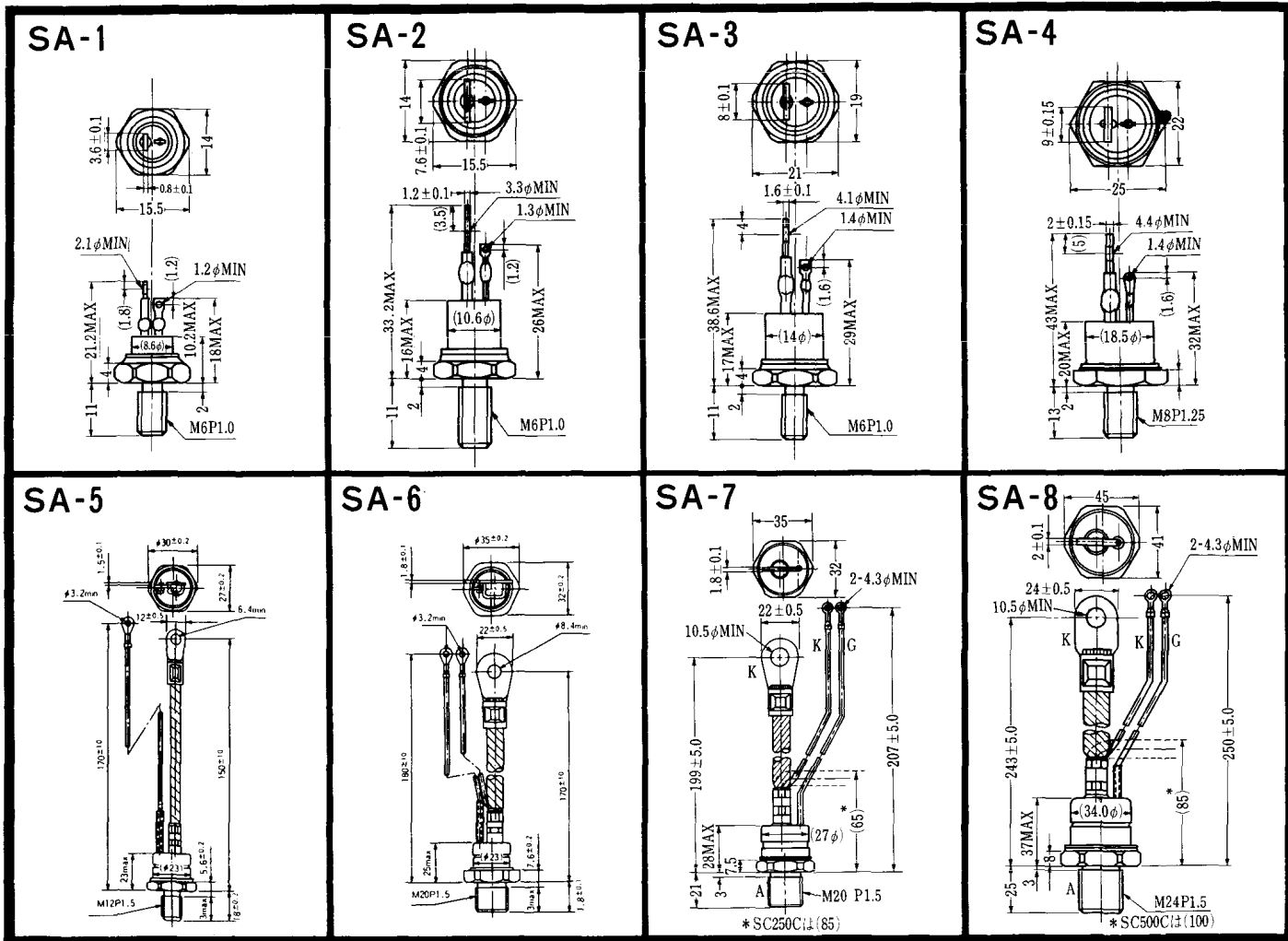

〈寸法図単位:mm〉

<http://store.iic.cc/>



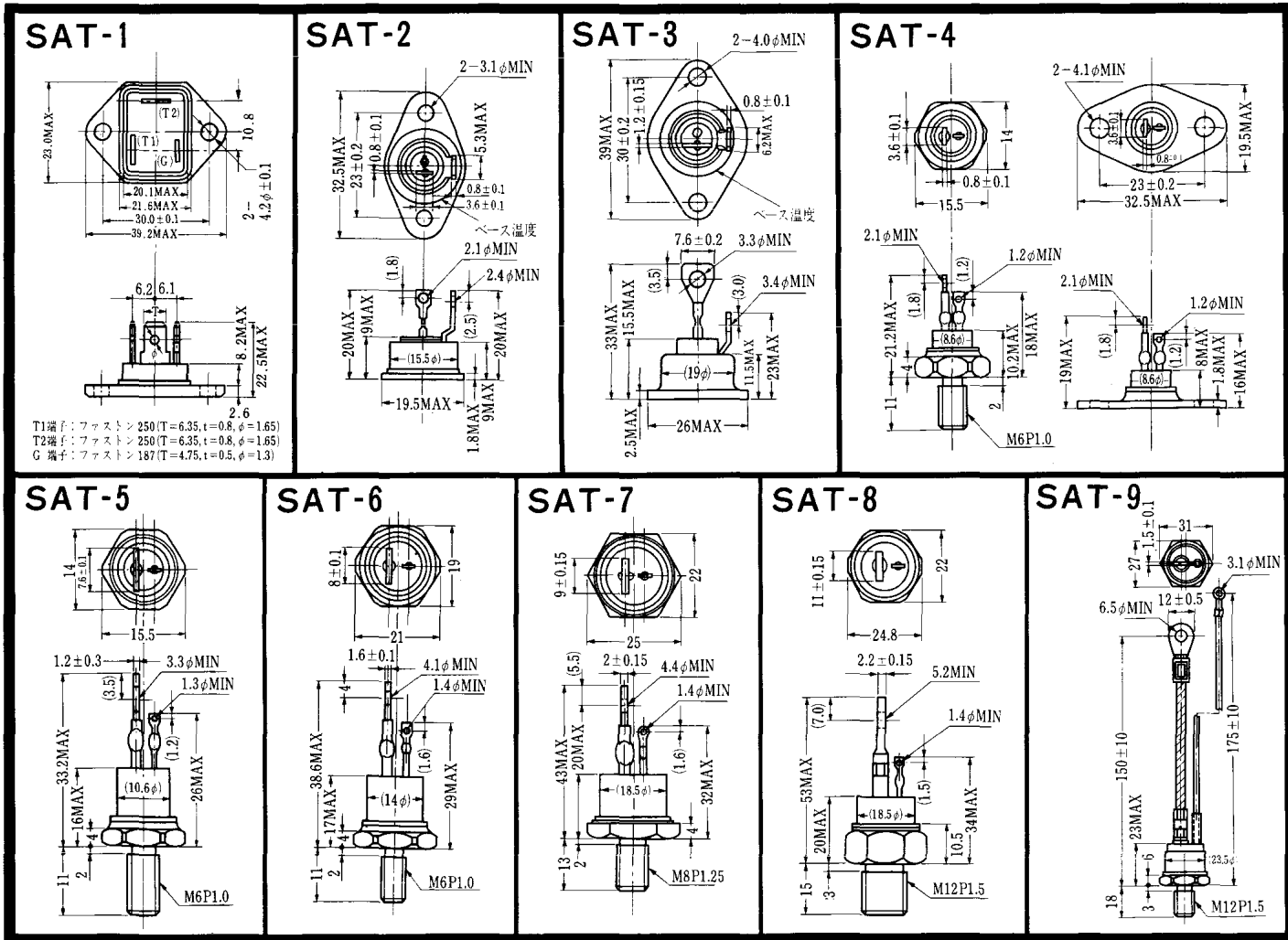

<http://store.iic.cc/>

《寸法図単位: mm》

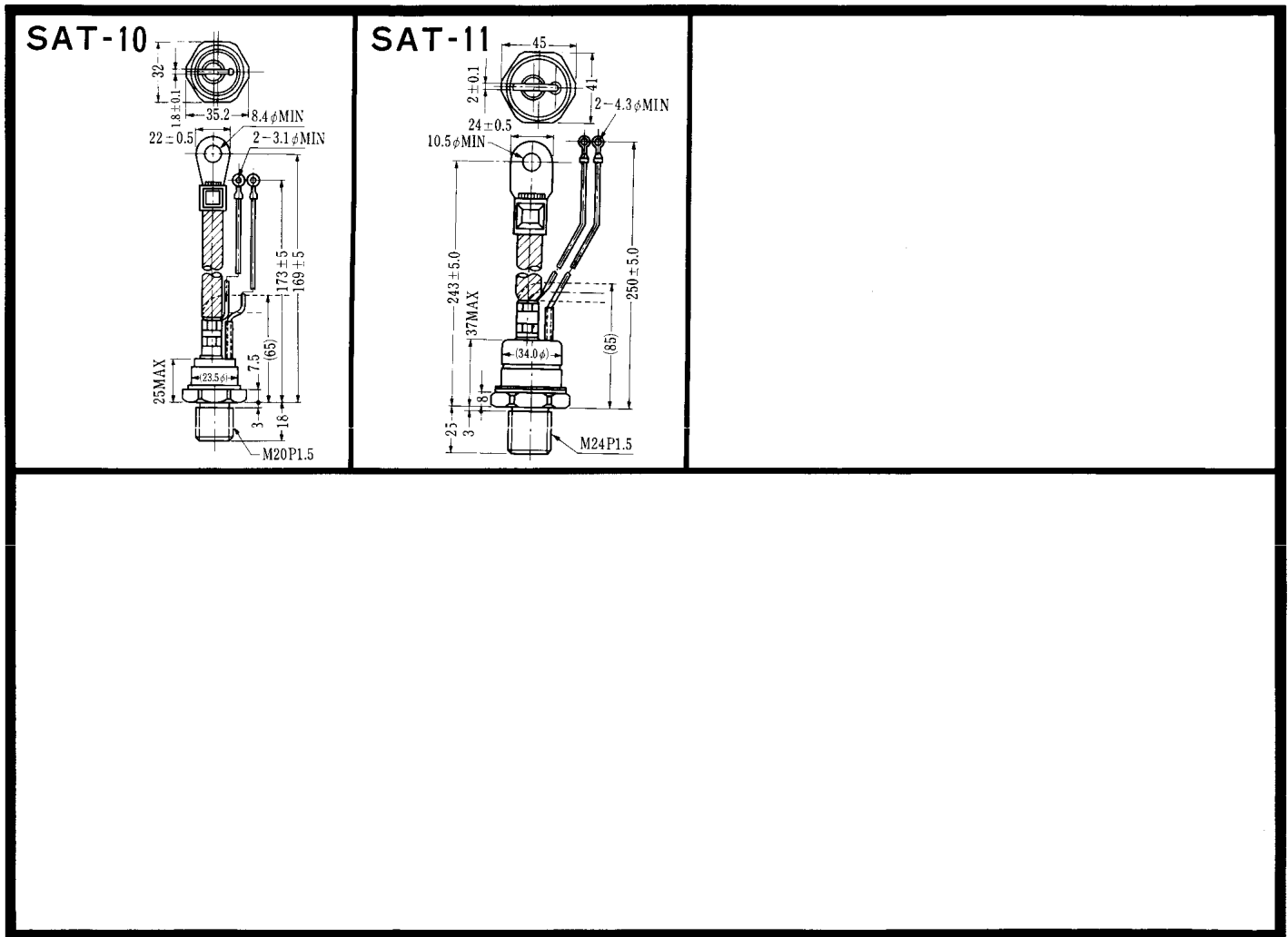

<http://store.iic.cc/>

《寸法図單位：mm》



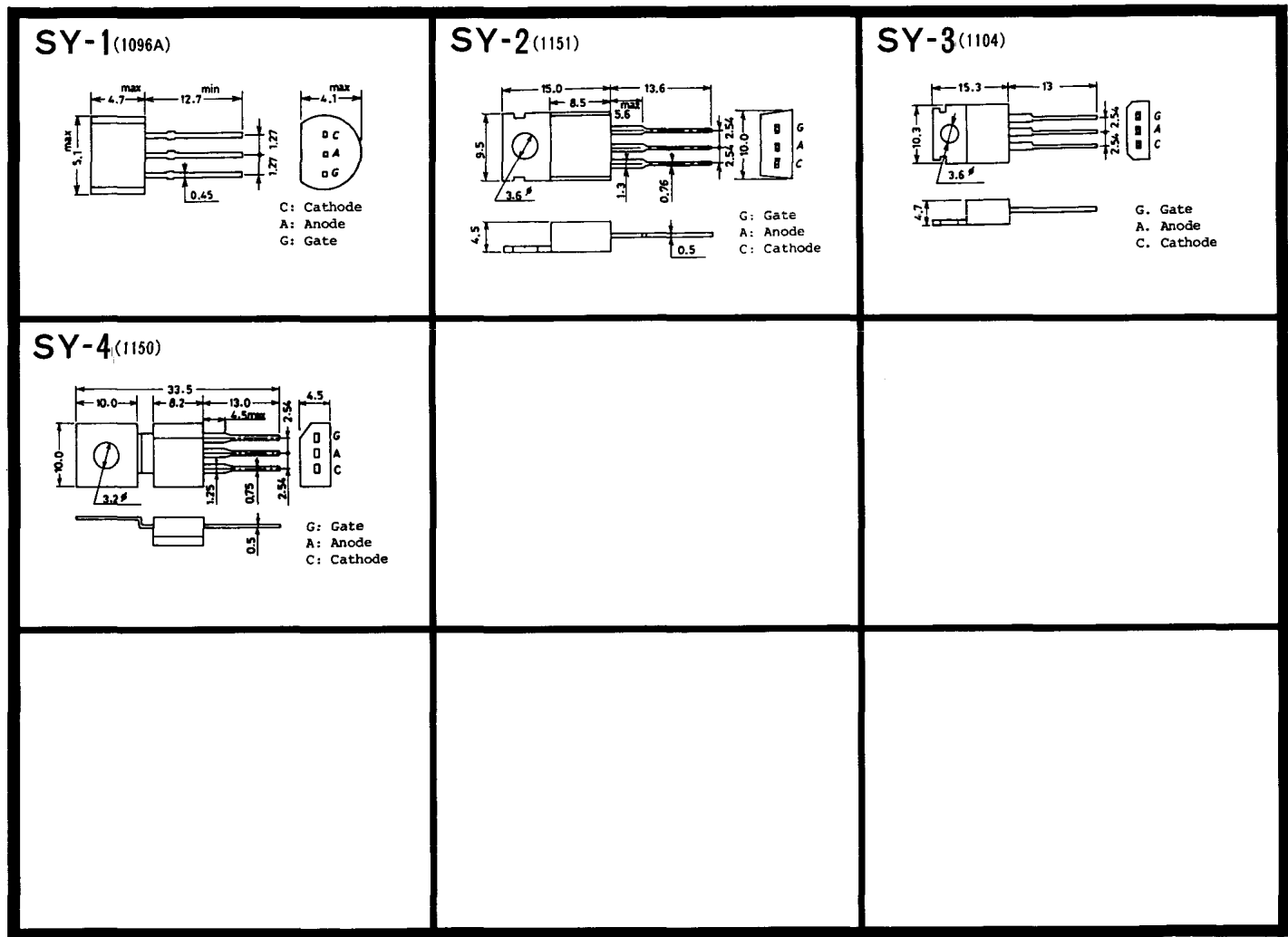

<http://store.iic.cc/>

〈寸法图单位:mm〉



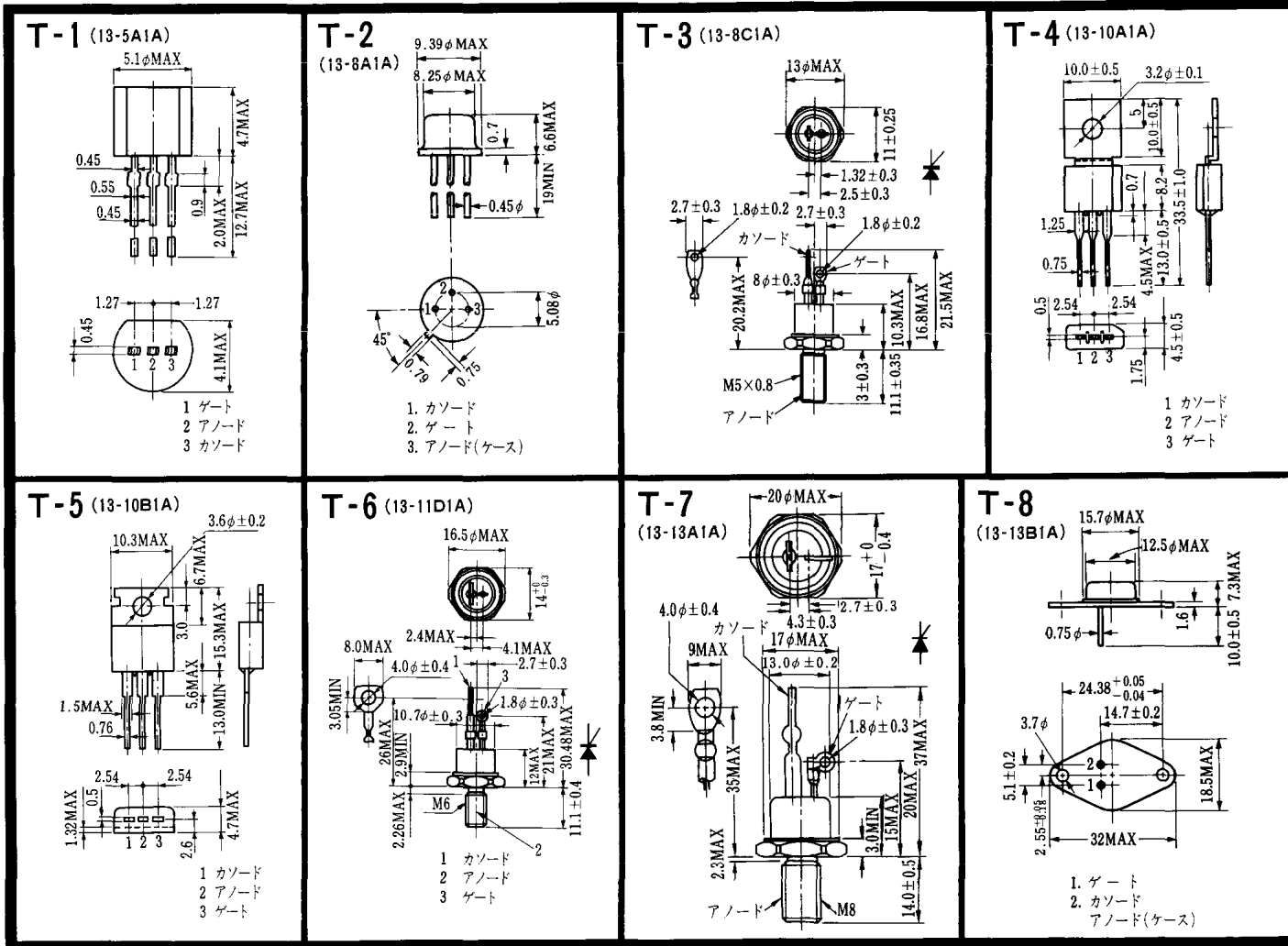

◀寸法図単位: mm

<http://store.iic.cc/>

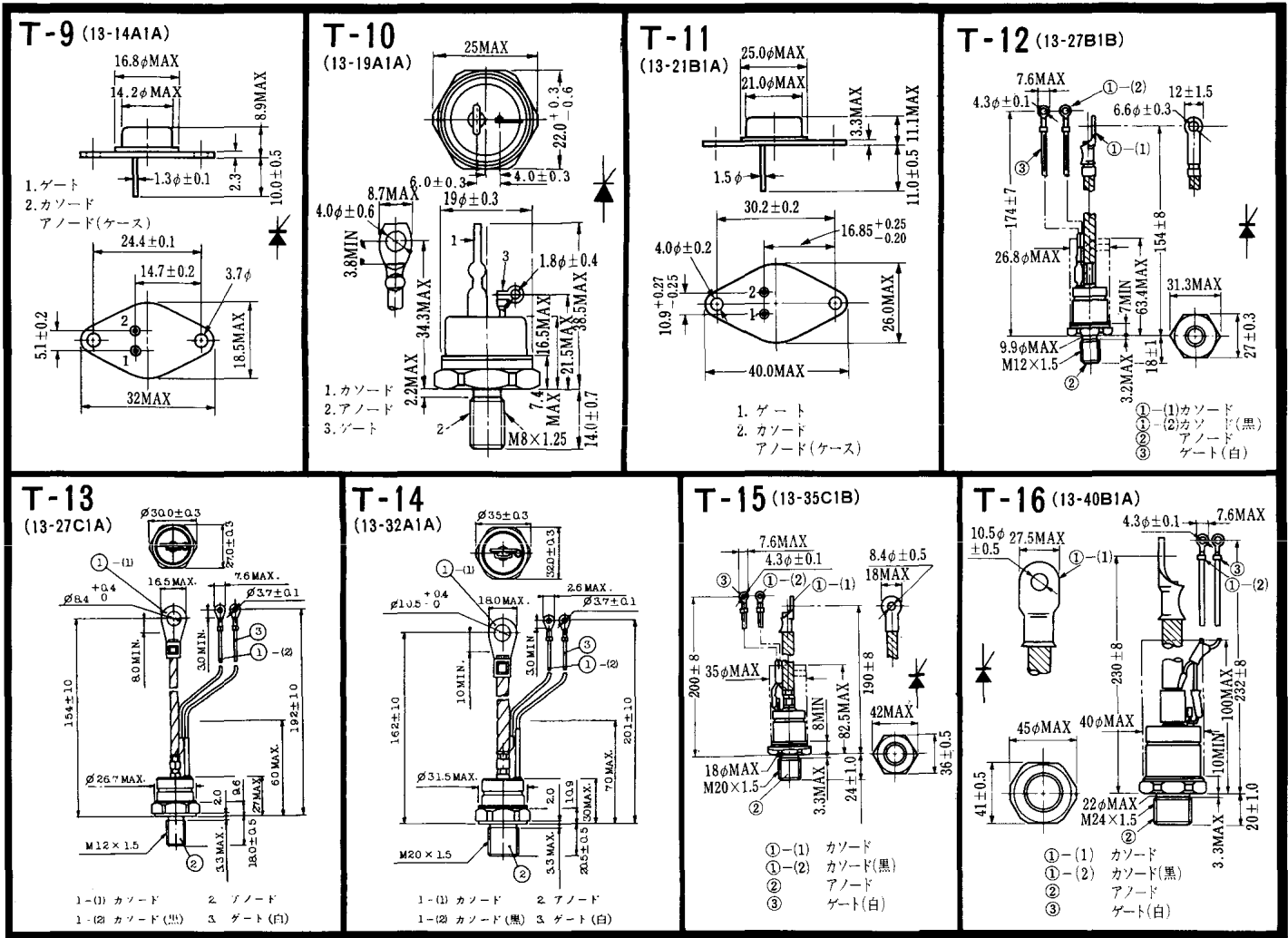

《寸法図単位：mm》

<http://store.iicc.cc/>

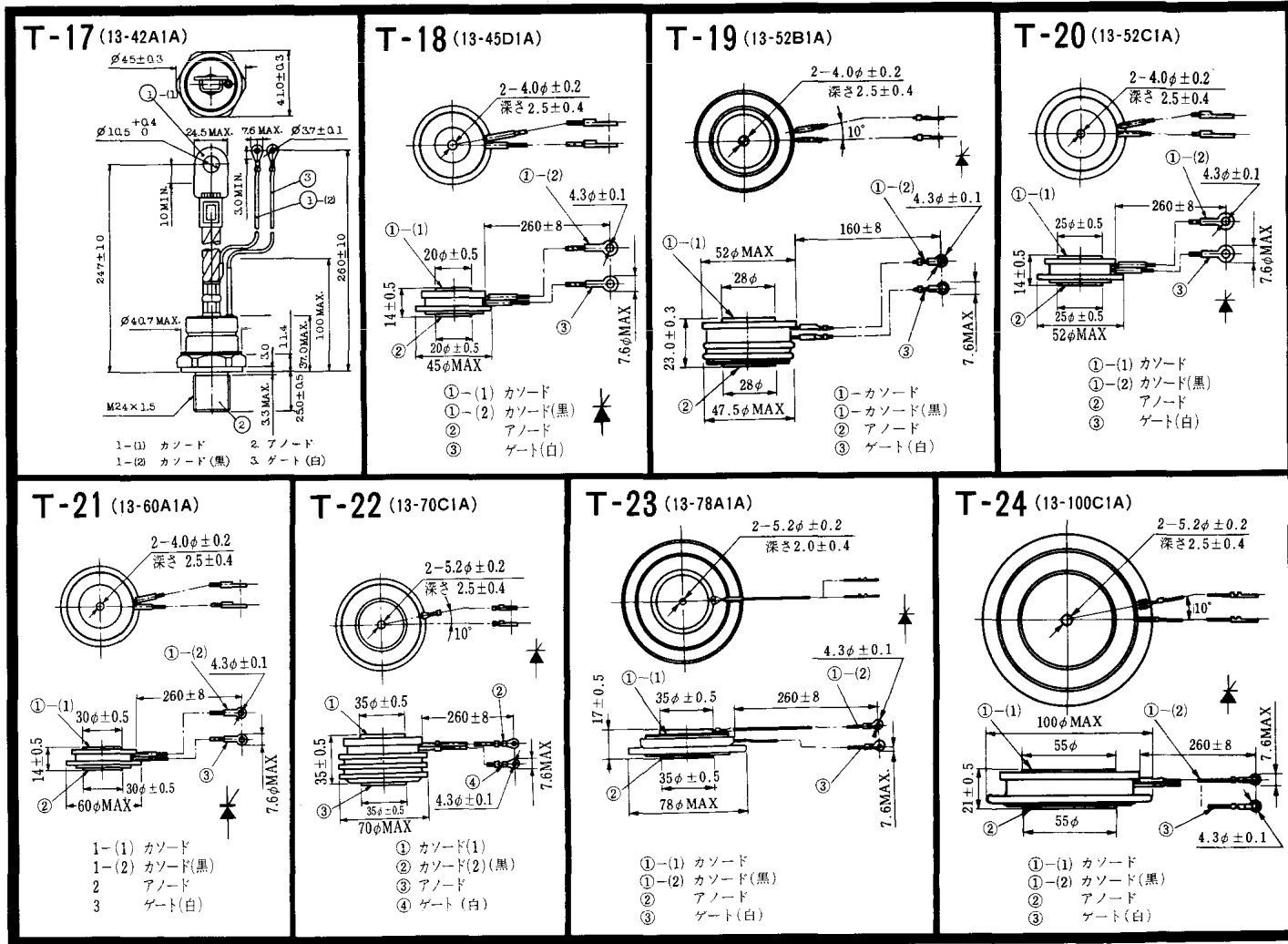

〈寸法図単位：mm〉

<http://store.iicc.cc/>

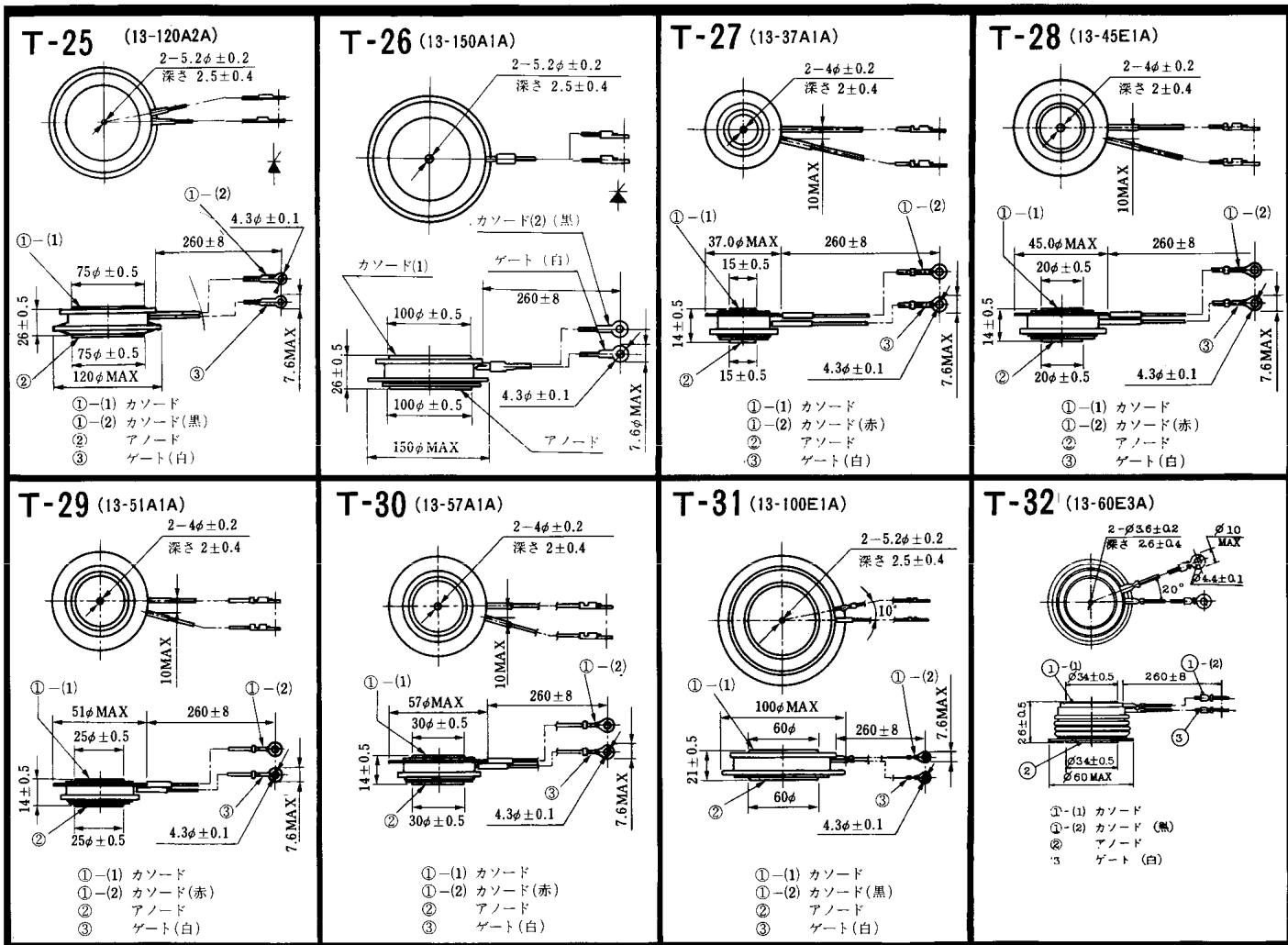

《寸法図単位：mm》

<http://store.iicc.cc/>

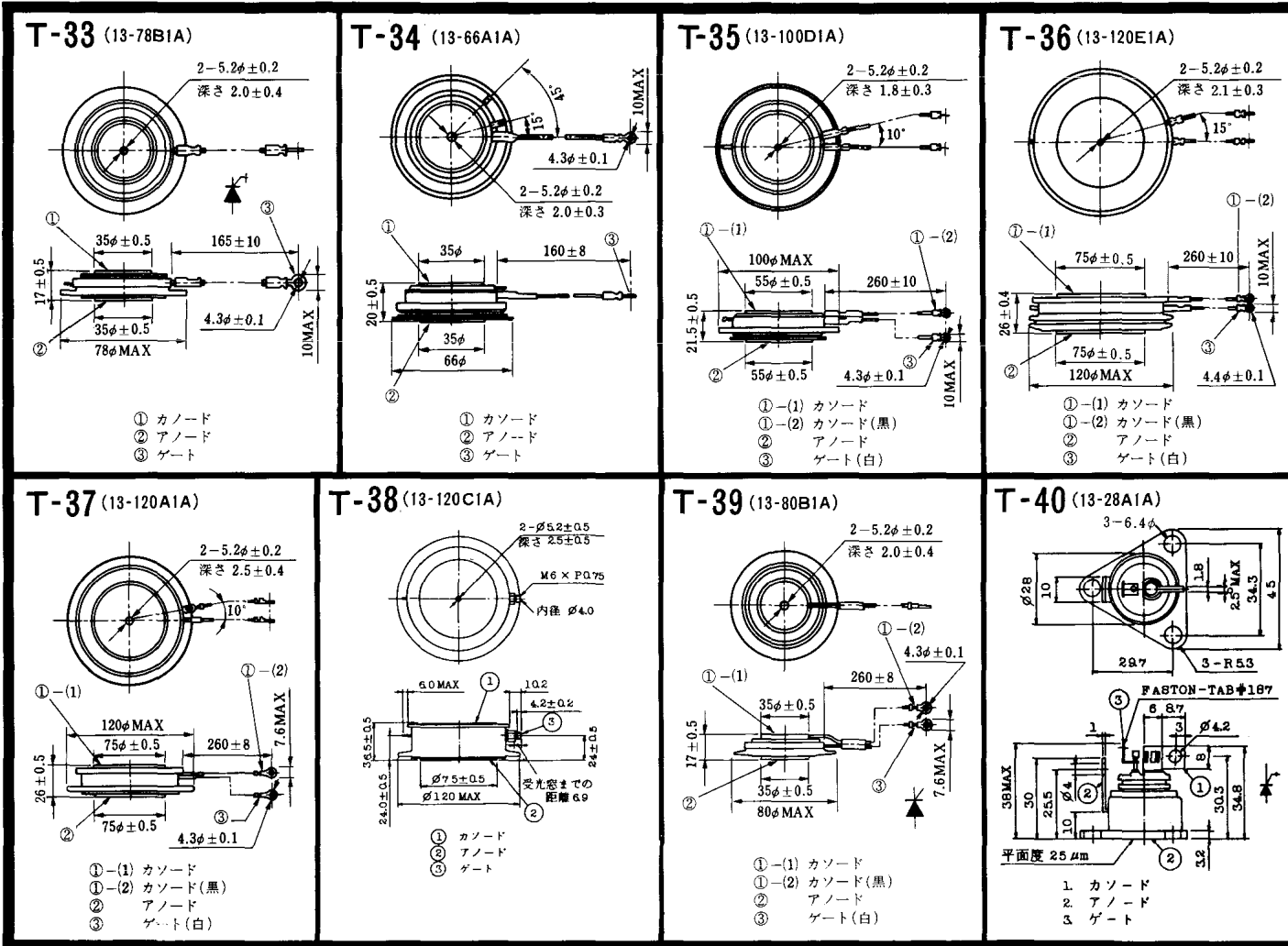

《寸法図単位：mm

<http://store.iic.cc/>





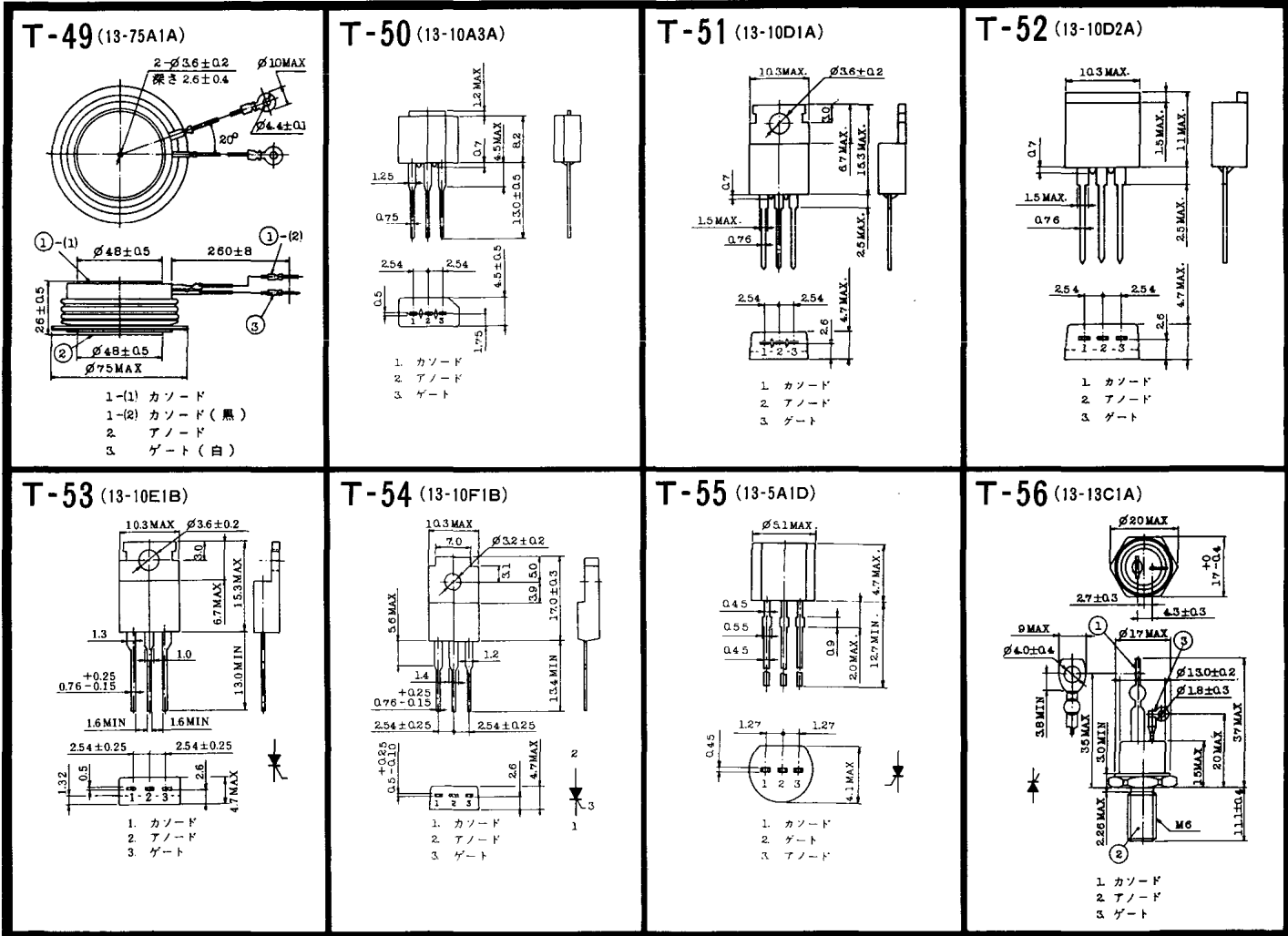

〈寸法図単位:mm〉

<http://store.iicc/>

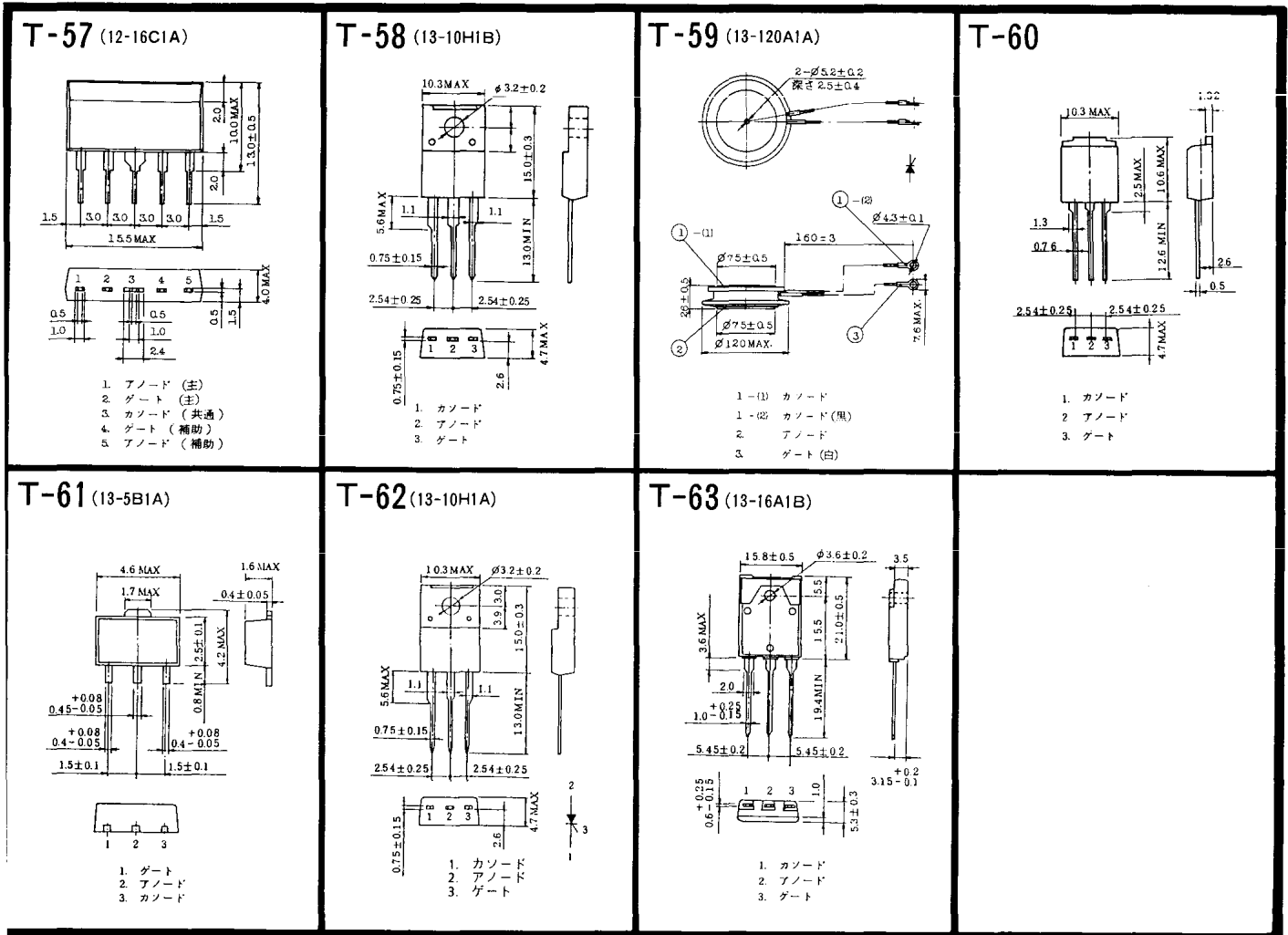

《寸法図単位:mm》

<http://store.iic.cc/>

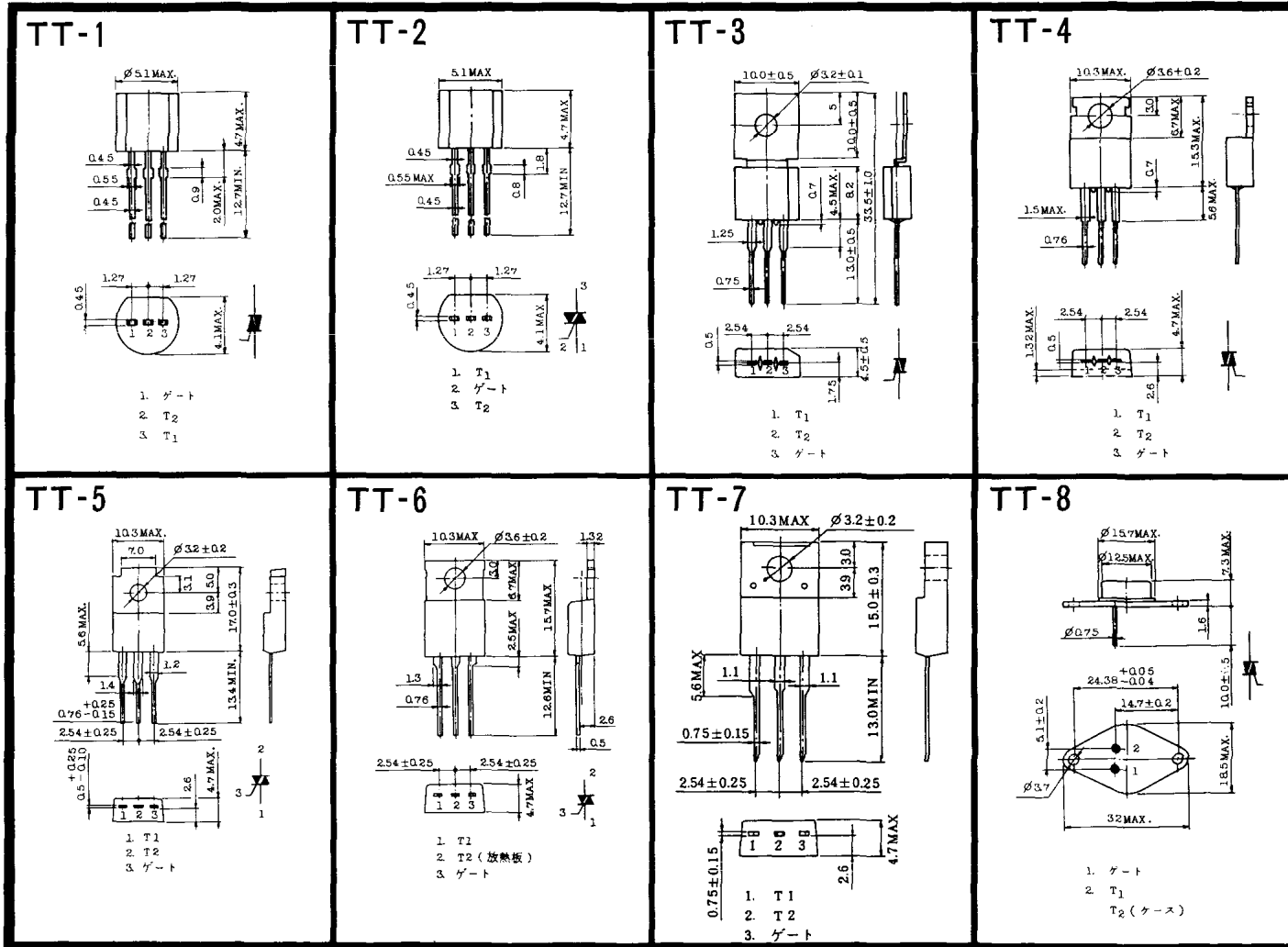

〈寸法図単位: mm〉

<http://store.iic.cc/>

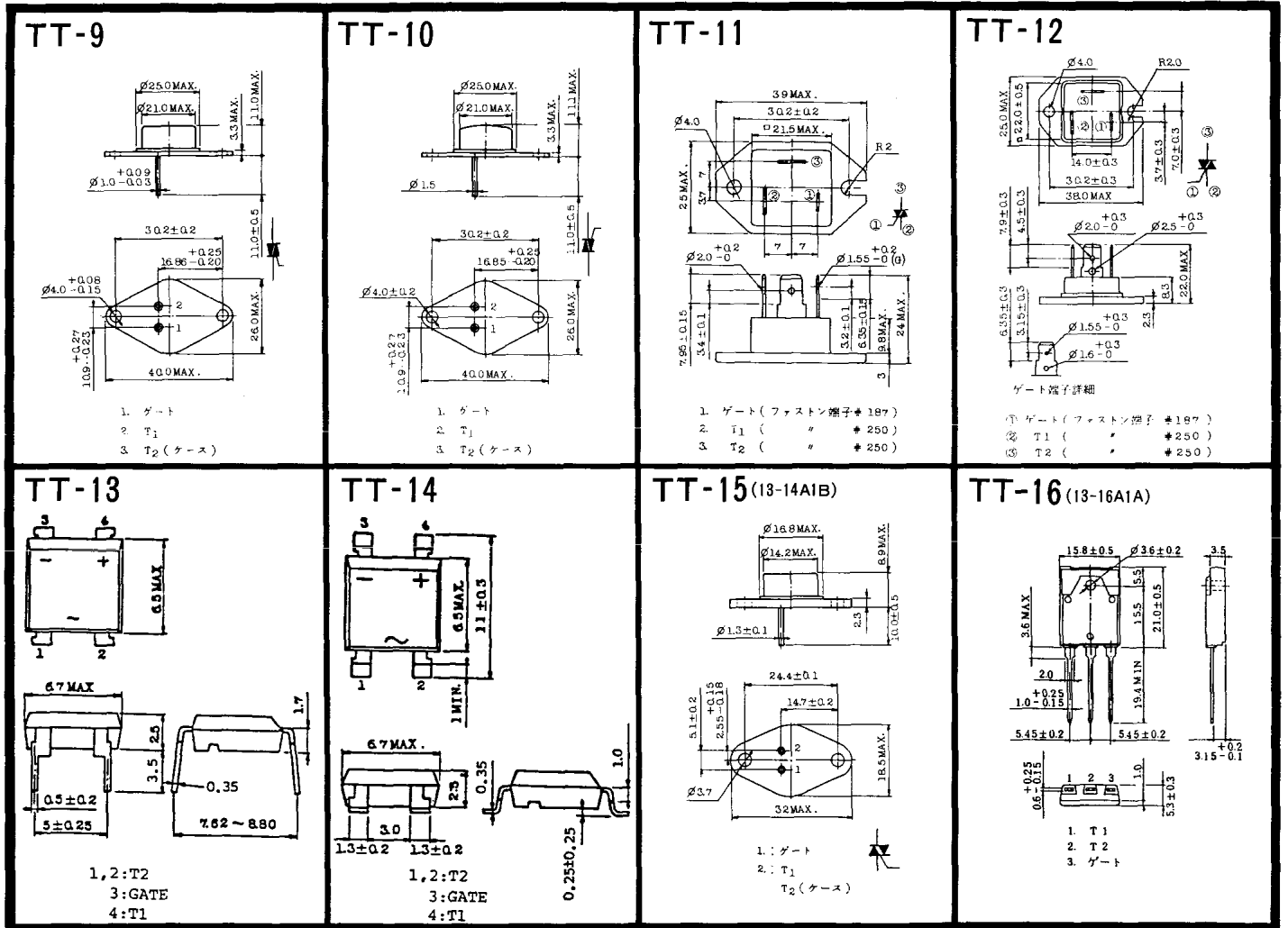

◀寸法図単位: mm▶

<http://store.iic.cc/>

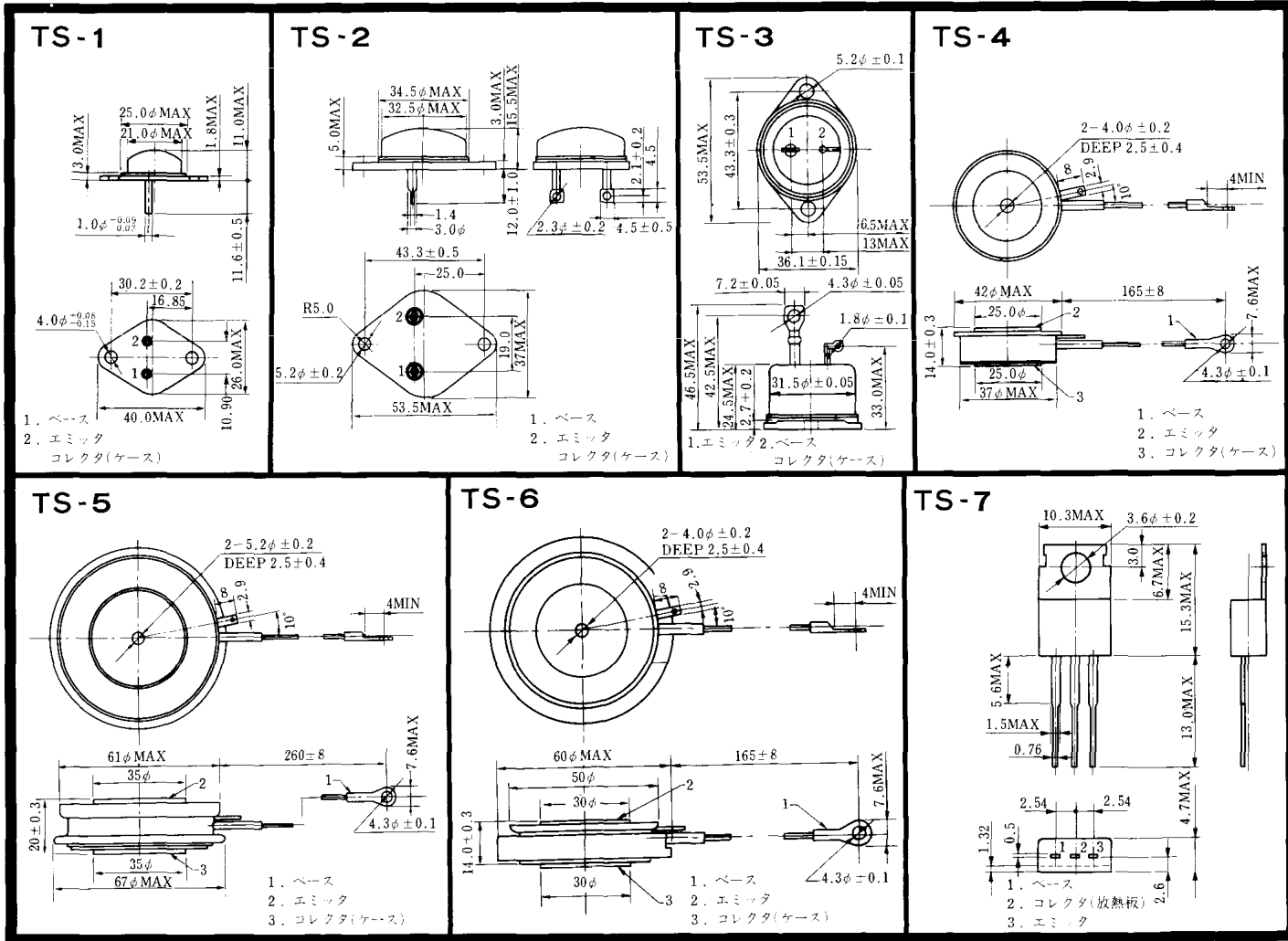

《寸法図単位：mm》

<http://store.iicc/>

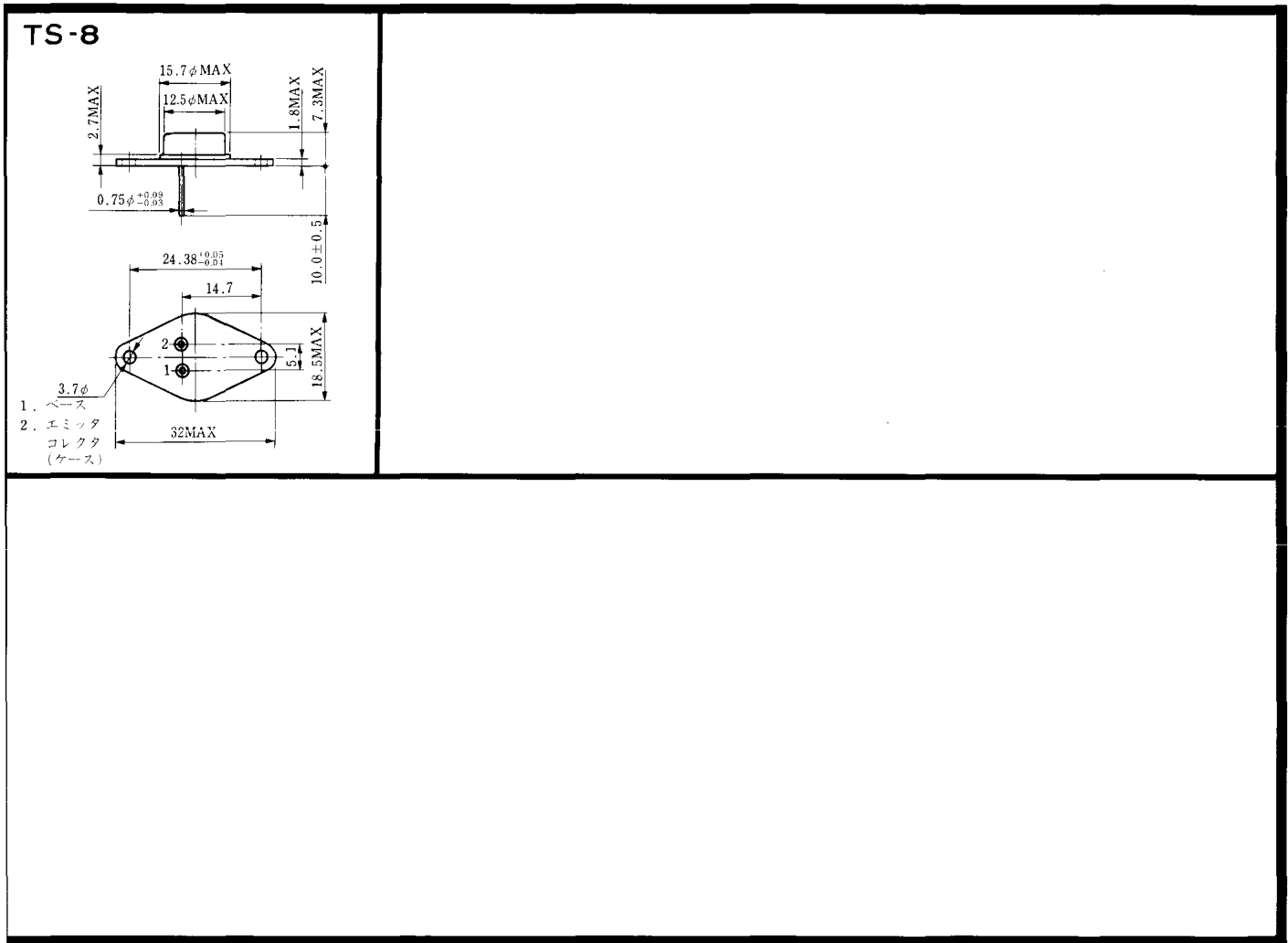

<http://store.iic.cc/>

《寸法図単位：mm》

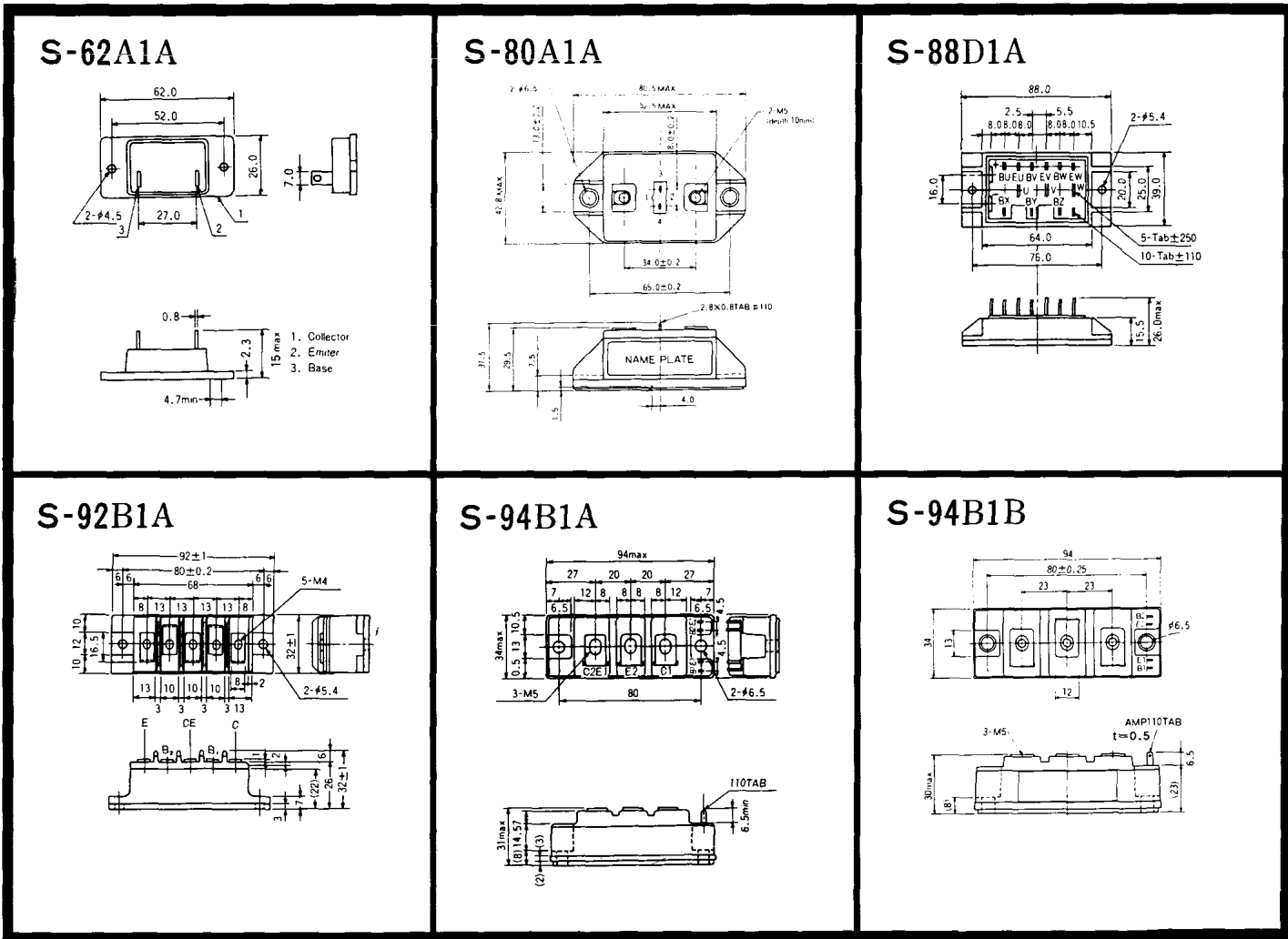

<http://store.iic.cc/>

〈寸法図単位：mm〉

S-94B2A

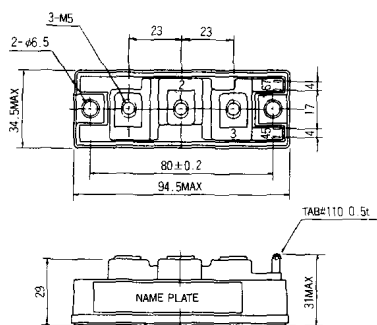

S-94D1A

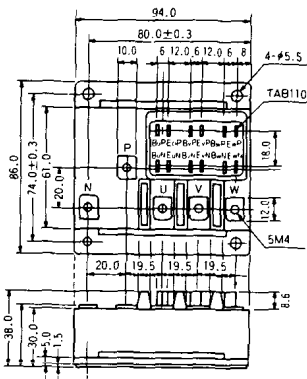

S-95A1A

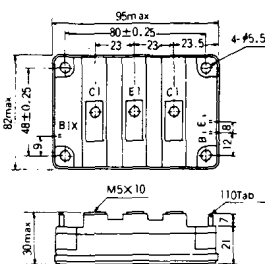

S-95B1A

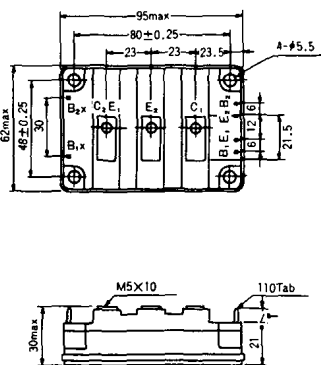

S-98B1B

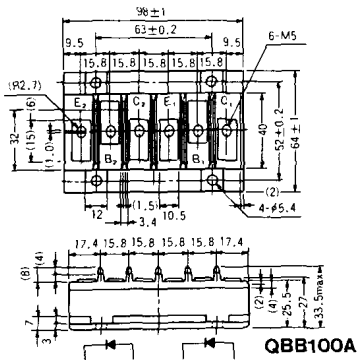

S-108A2A

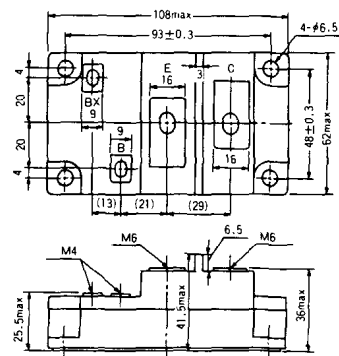

〈寸法図単位: mm〉

<http://store.iic.cc/>



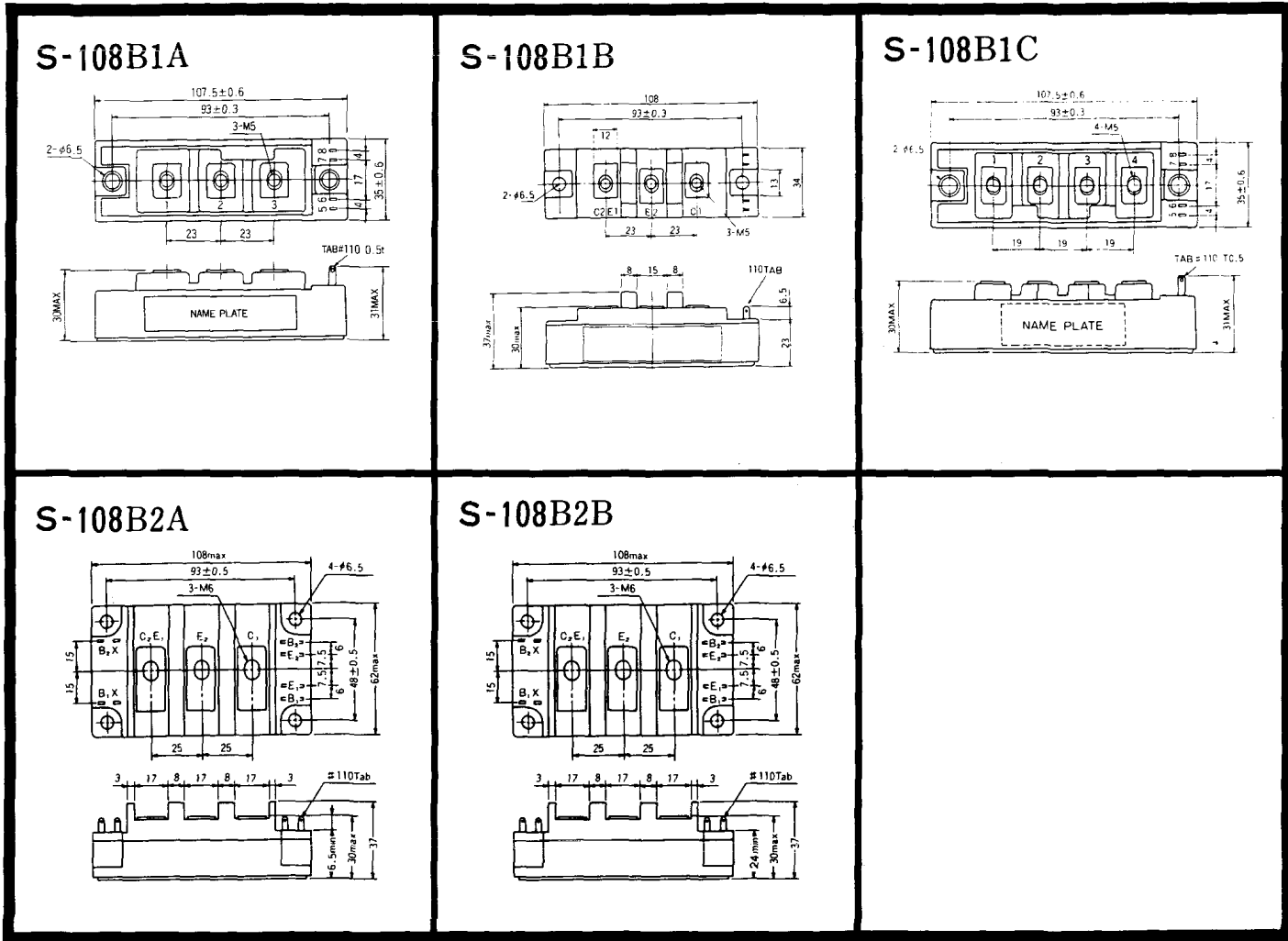

<http://store.iic.cc/>

<寸法图单位:mm>

### 2-22B1A

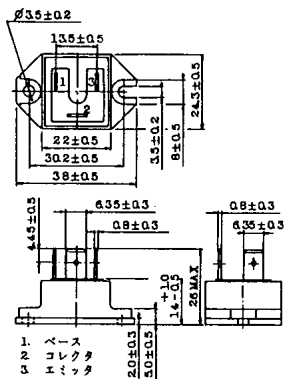

### 2-27A4A

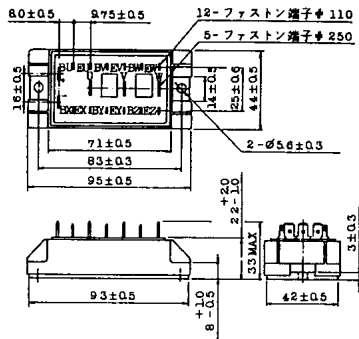

### 2-33C1A

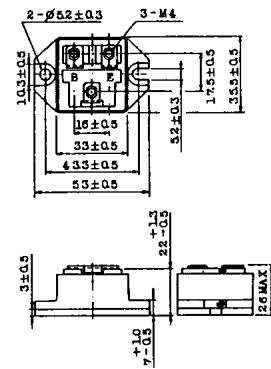

### 2-33D1A

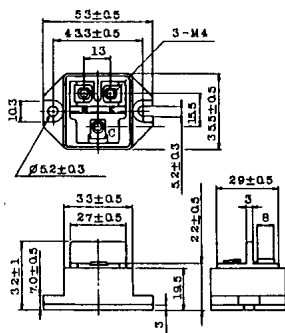

### 2-33F1A

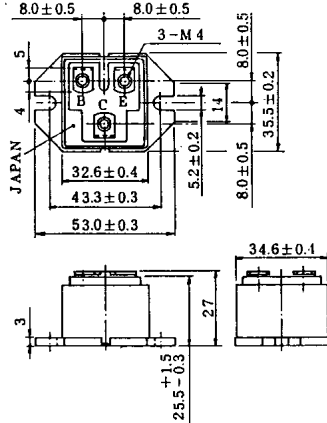

### 2-37A1A

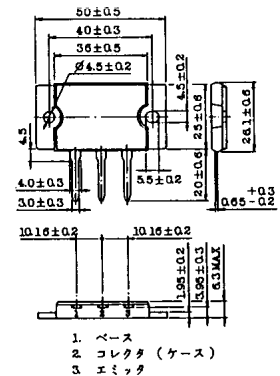

<http://store.iicc.cc/>

〈寸法図単位：mm〉

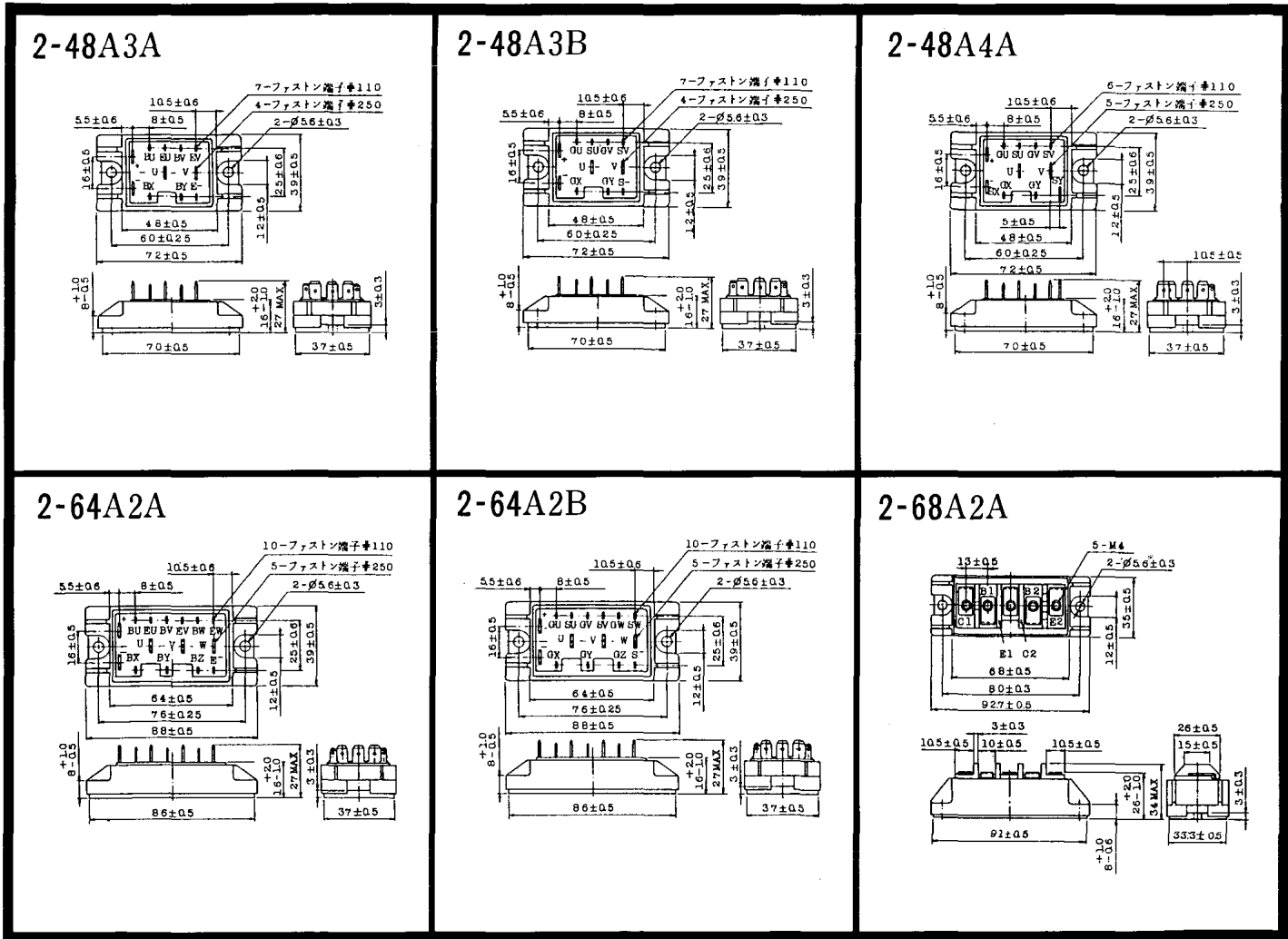

<http://store.iic.cc/>

〈寸法図単位：mm〉

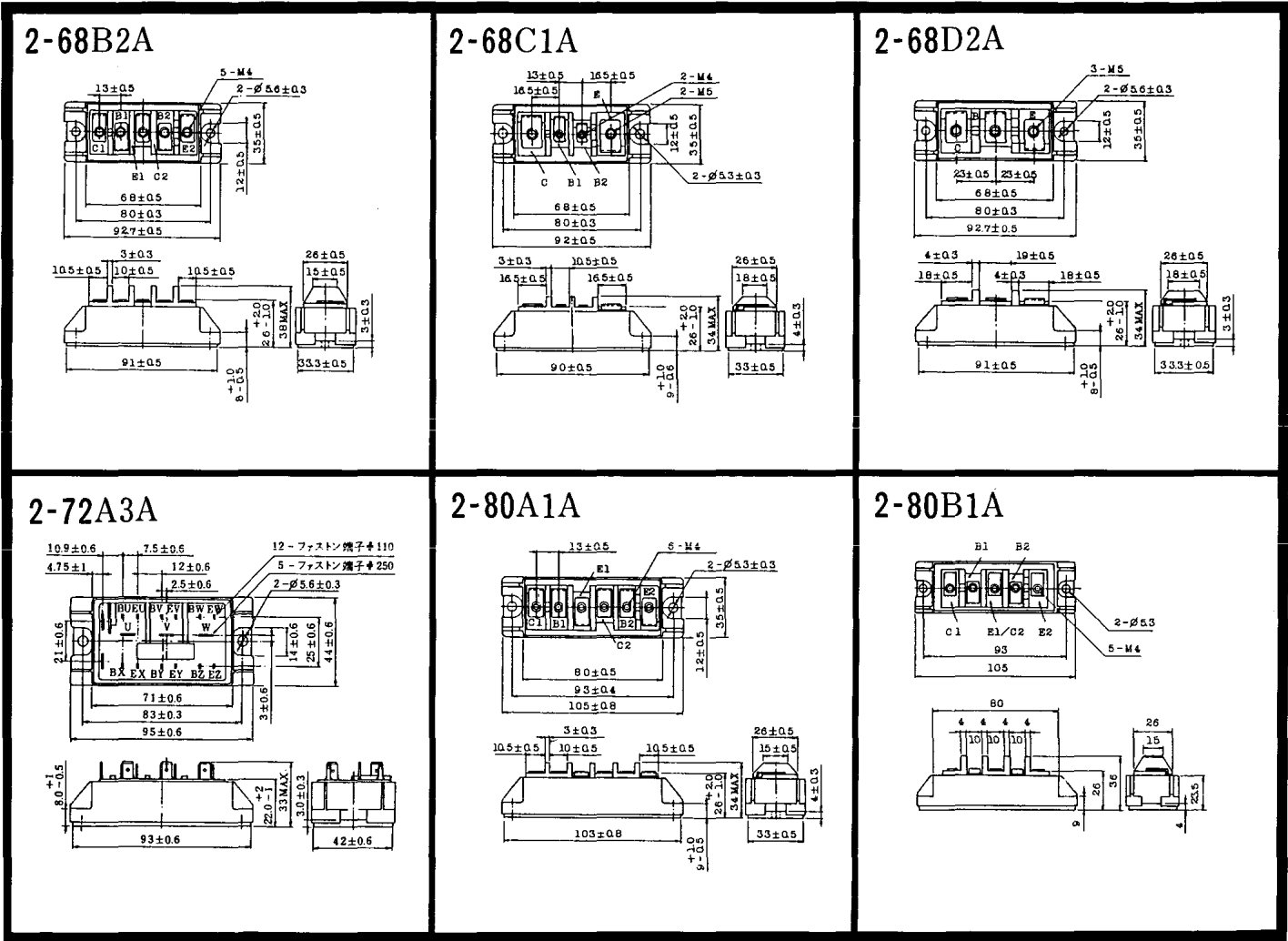

<http://store.iicc/>

〈寸法図単位：mm〉

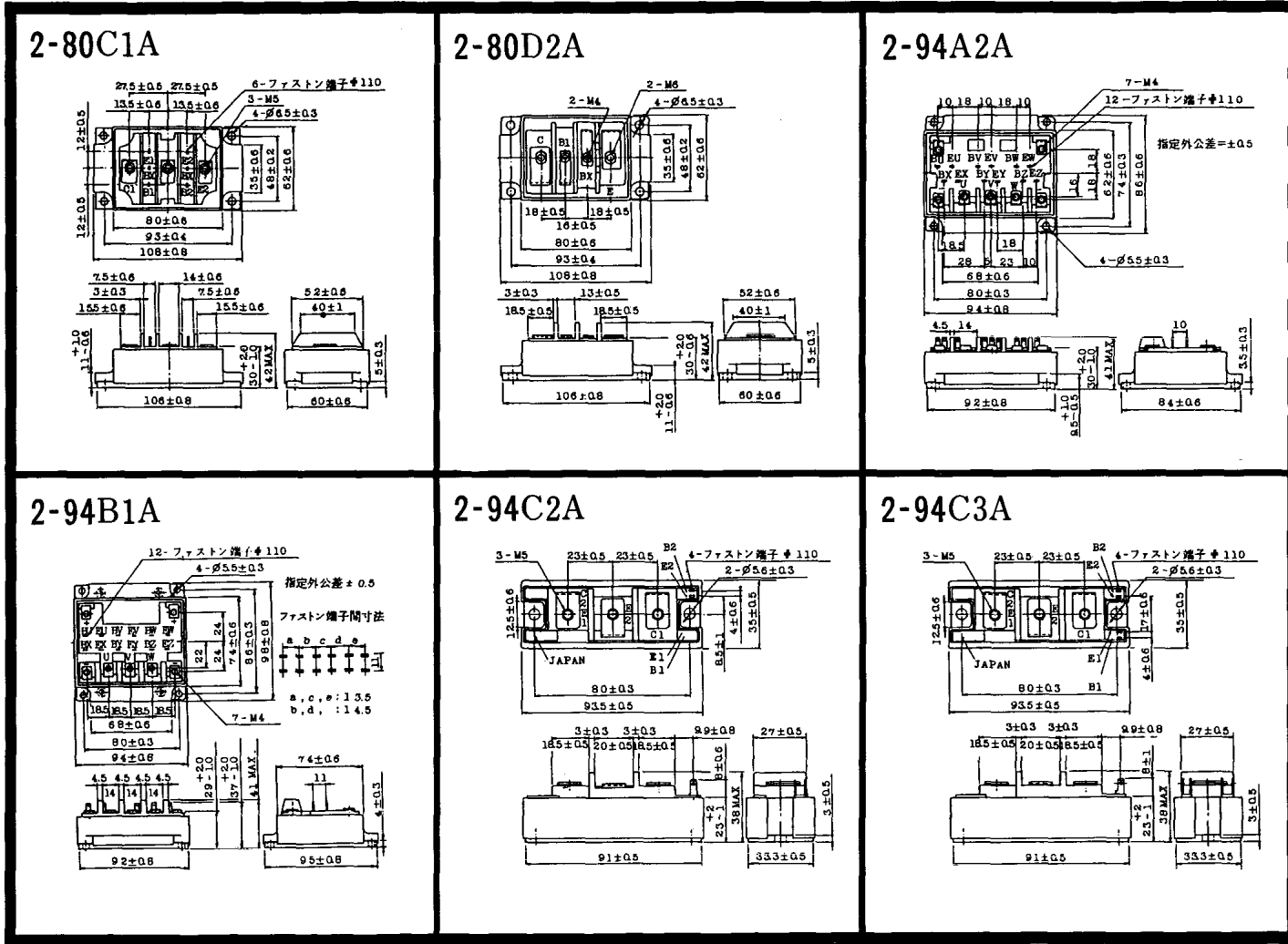

〈寸法図単位：mm〉

<http://store.iic.cc/>

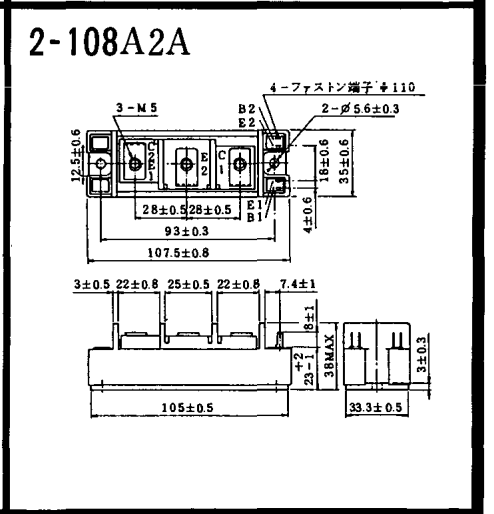
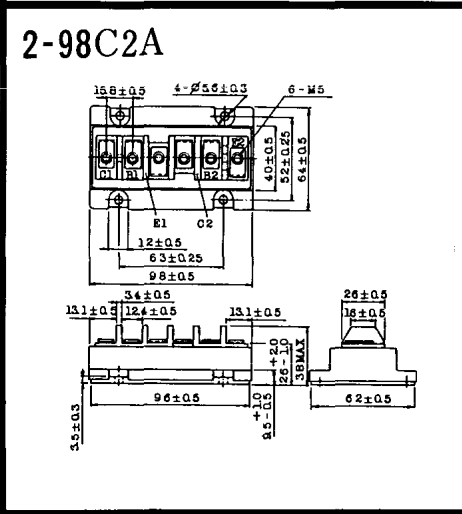
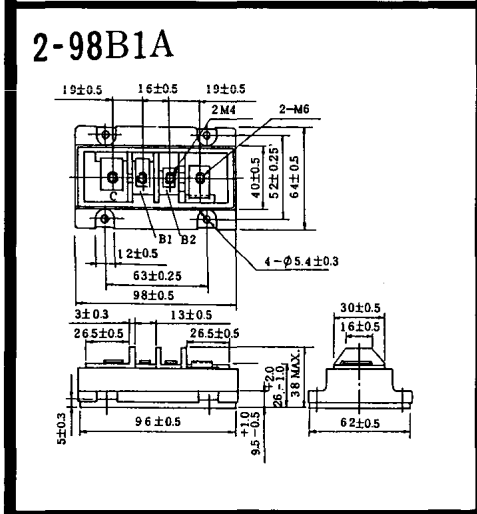
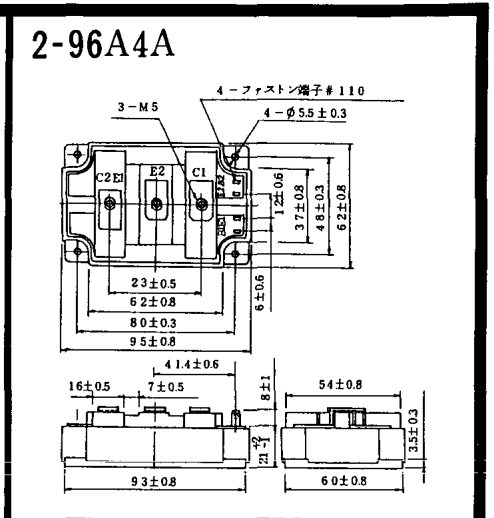
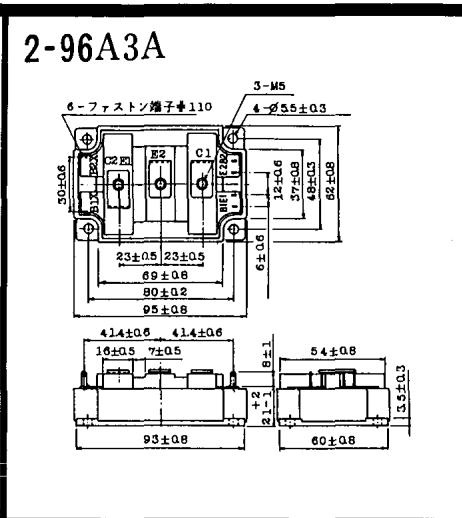
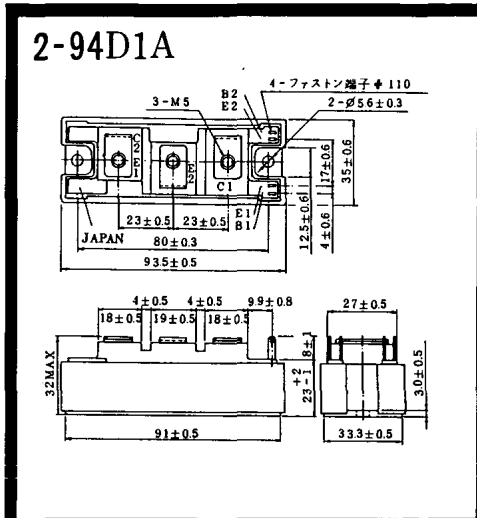

<http://store.iicc/>

《寸法図単位：mm》

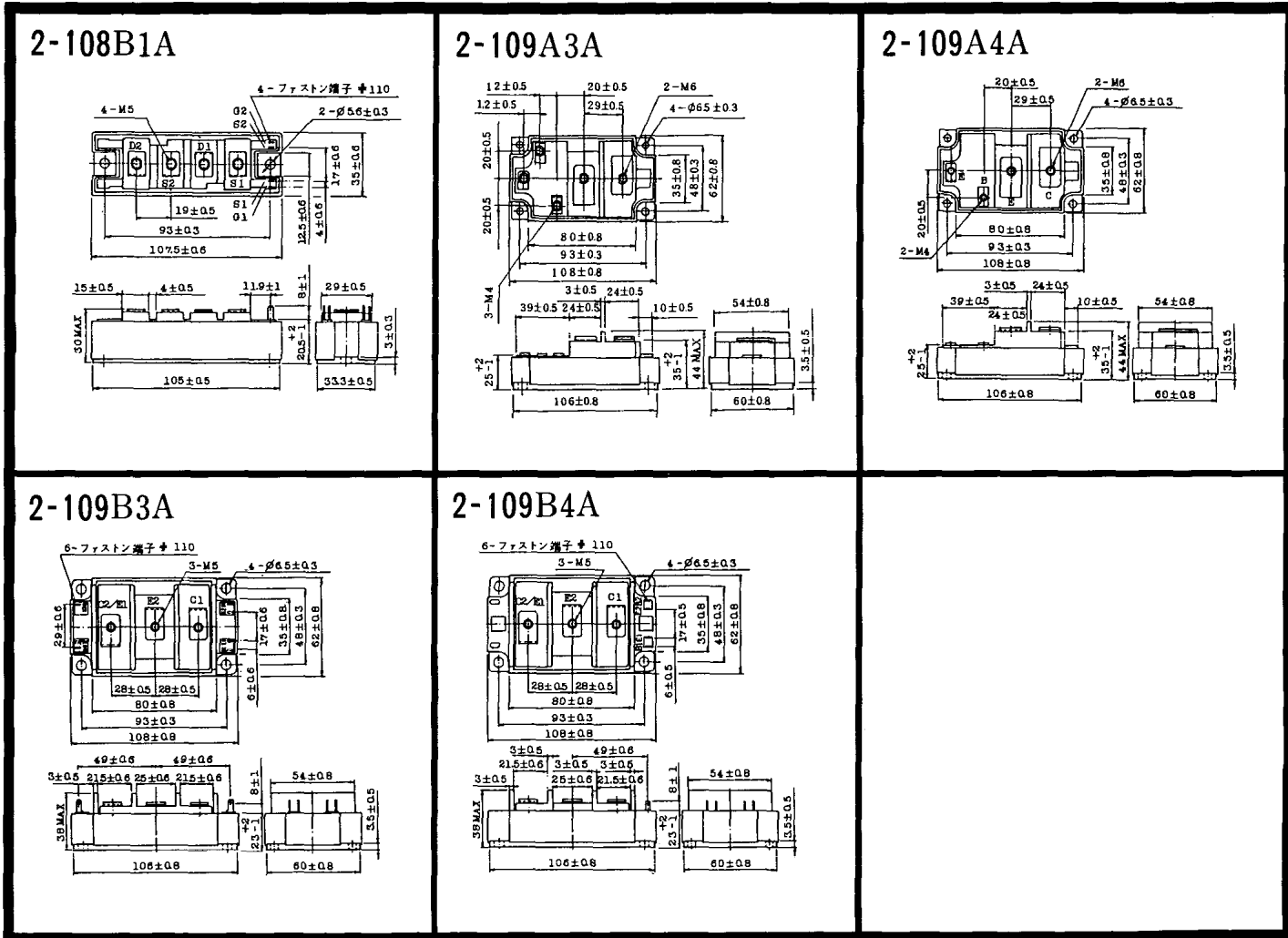

<寸法図単位: mm>

<http://store.iic.cc/>

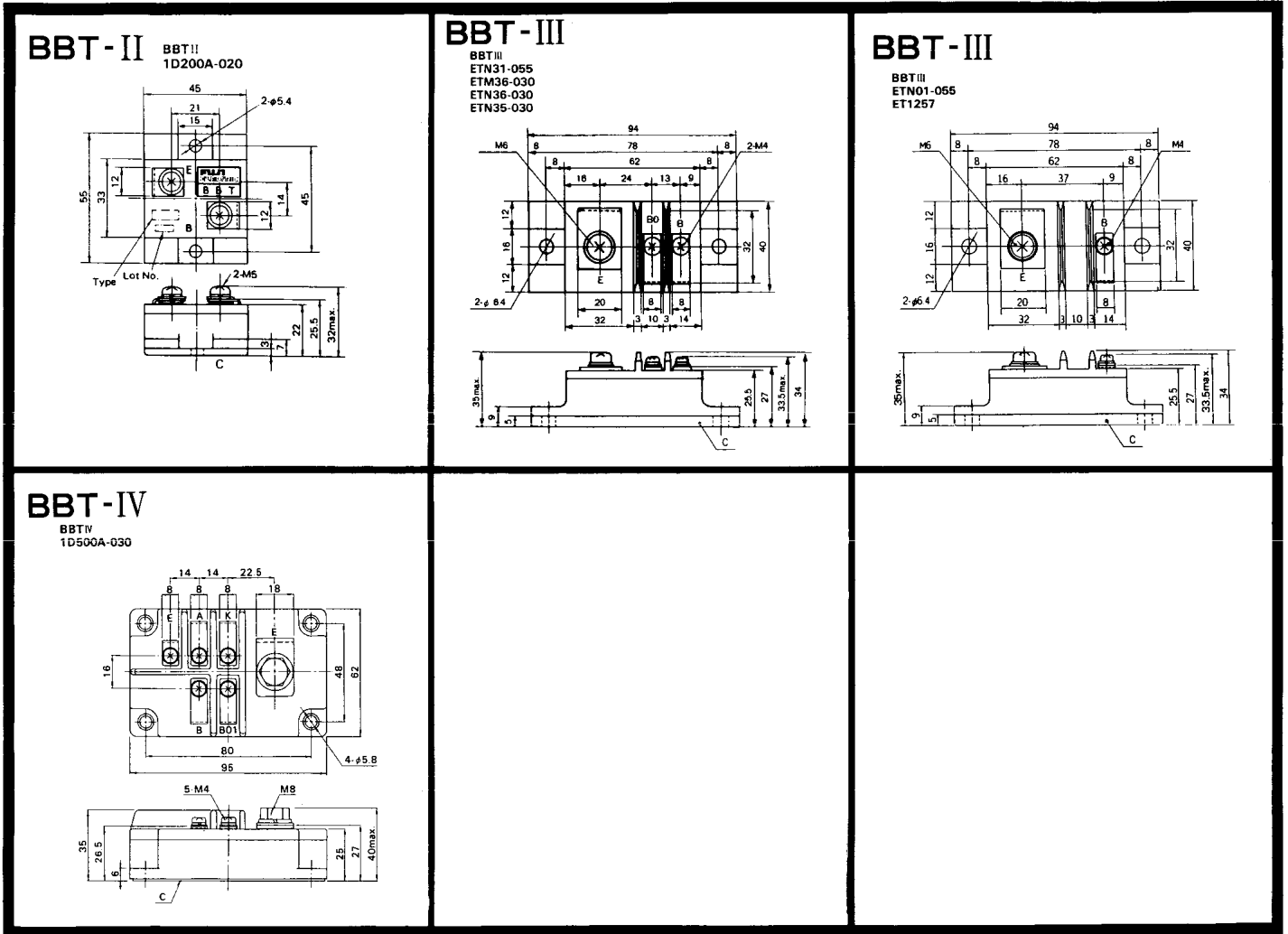

<http://store.iic.cc/>

〈寸法图单位:mm〉





M-107

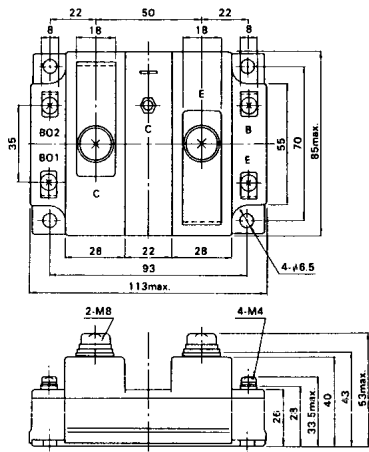

M-116

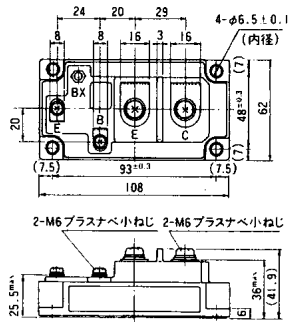

<http://store.iic.cc/>

〈寸法図単位：mm〉

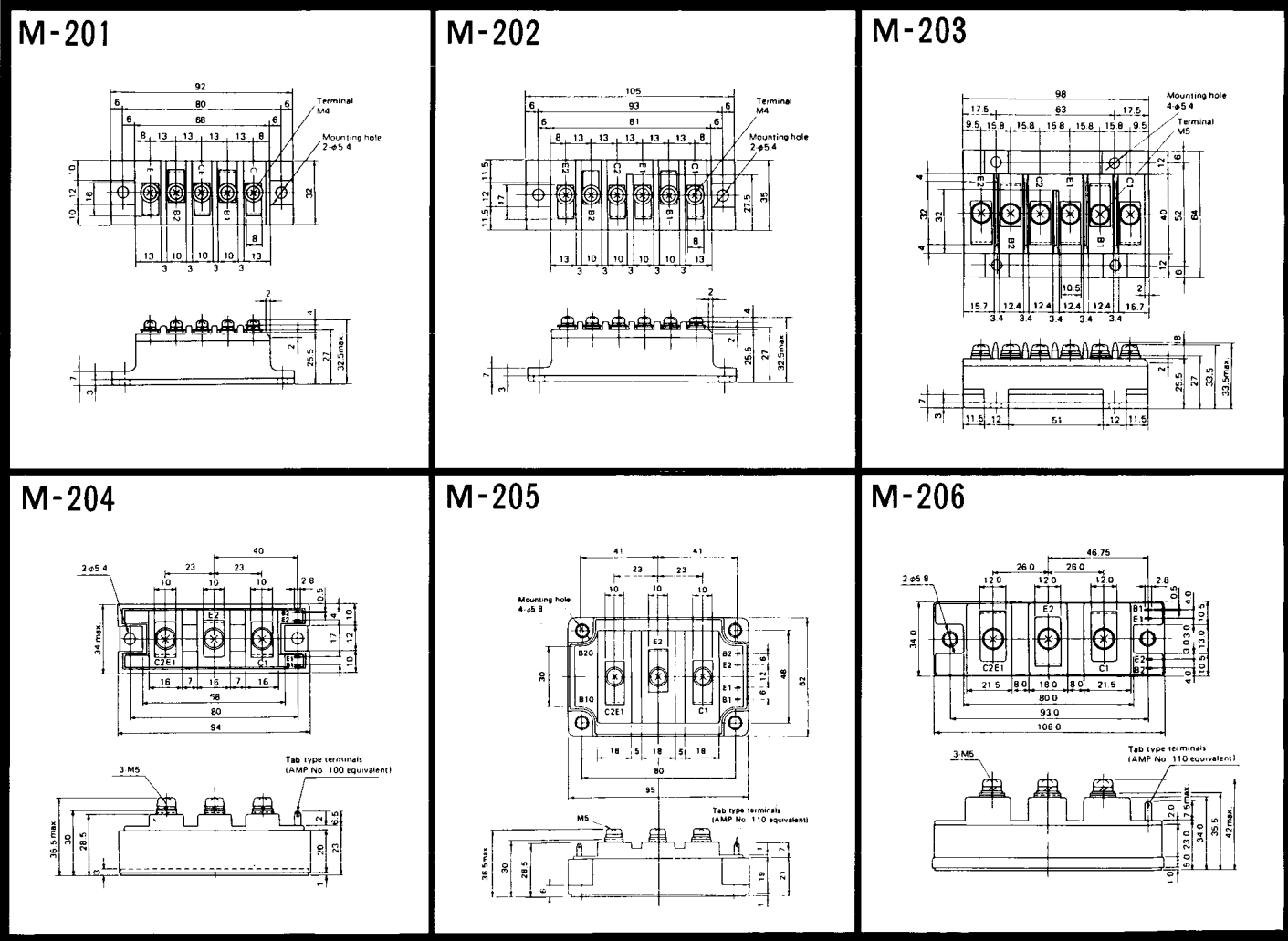

<http://store.iicc/>

〈寸法図単位：mm〉

**M-207**

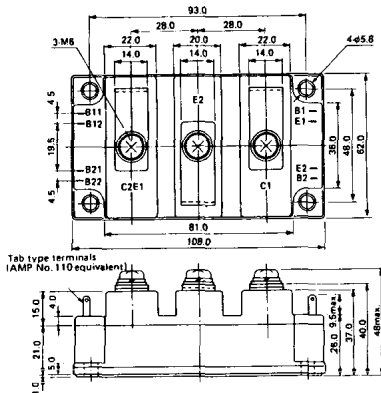

**M-208**

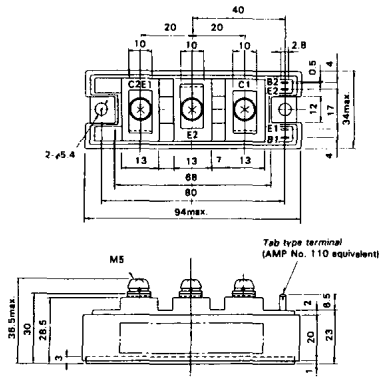

**M-209**

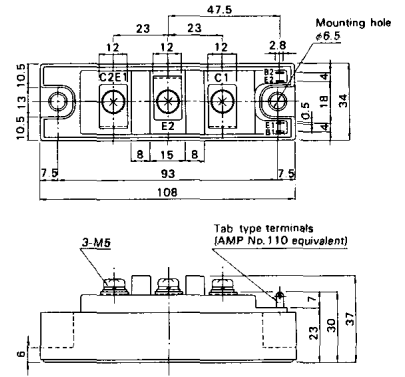

**M-210**

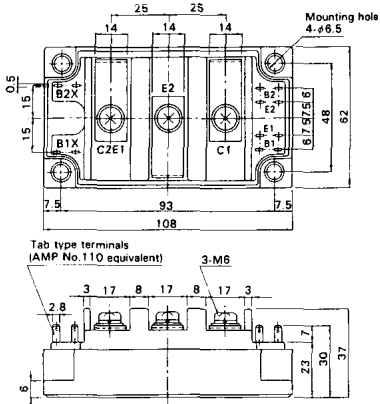

**M-211**

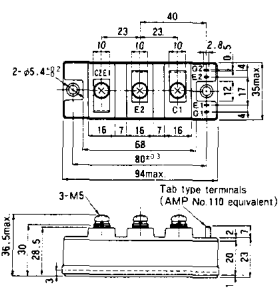

**M-212**

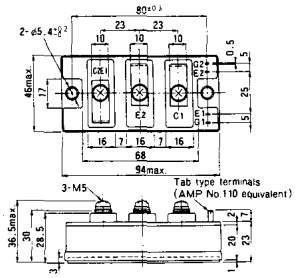

《寸法図単位：mm》

<http://store.iic.cc/>

M-213

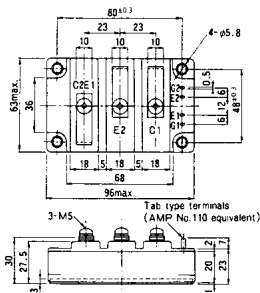

M-214

M-215

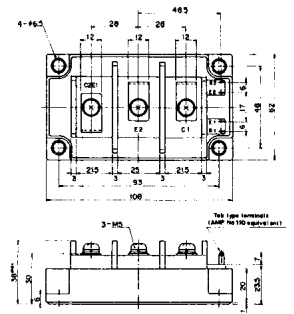

M-216

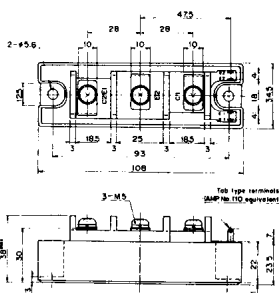

M-217

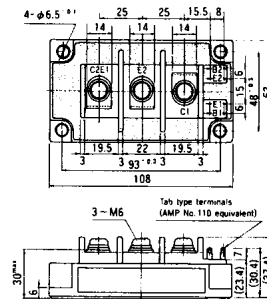

M-218

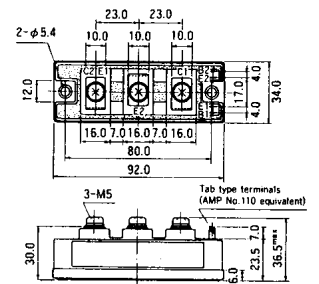

〈 寸法図単位:mm 〉

<http://store.iicc.cc/>

# M-219

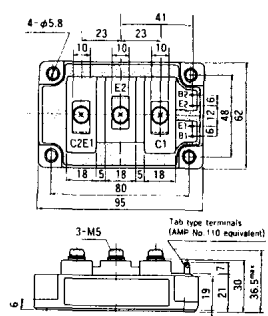

〈寸法図単位:mm〉

<http://store.iic.cc/>

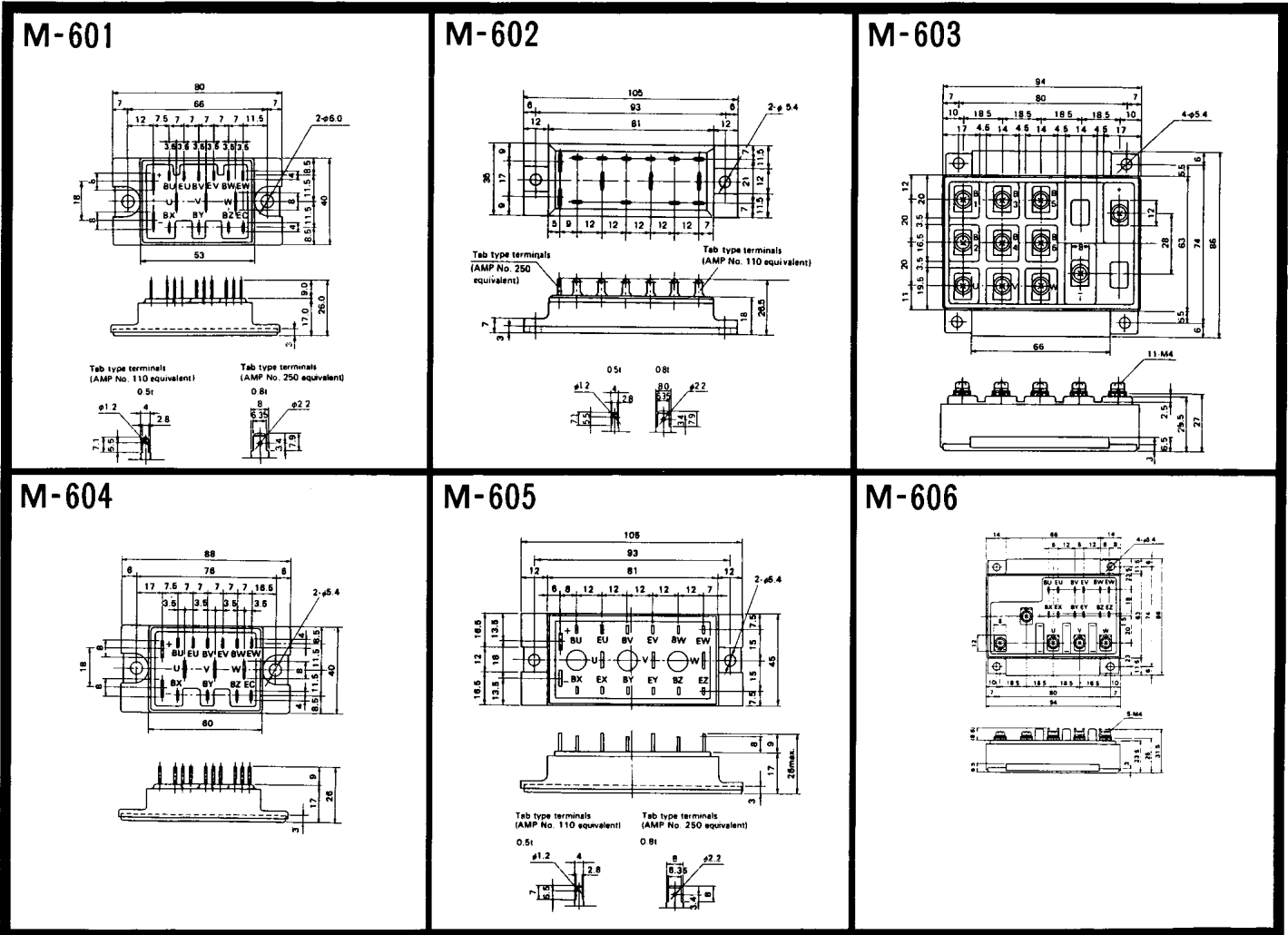

《寸法図単位：mm》

<http://store.iicc.cc/>

M-607

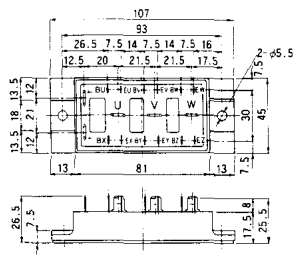

M-608

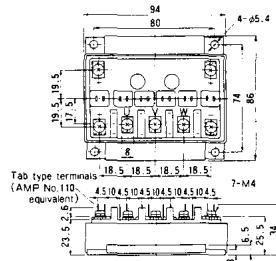

M-609

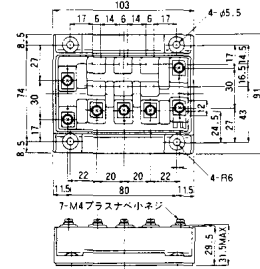

M-610

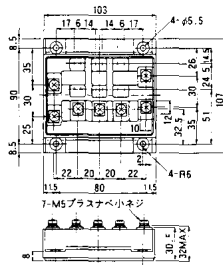

M-616

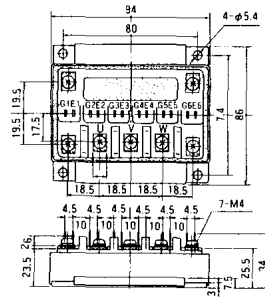

◀ 寸法図単位:mm ▶

<http://store.iic.cc/>













M-8A1B

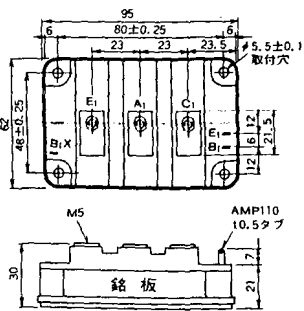

M-8A2A

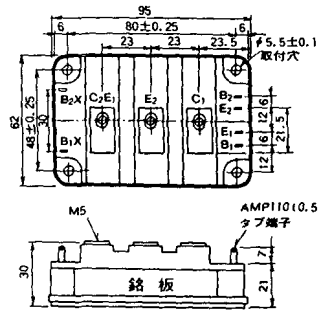

M-8A2B

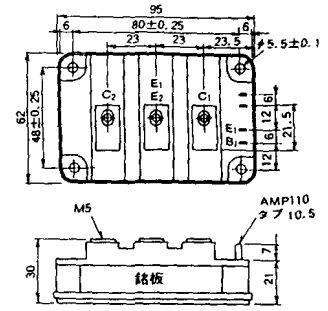

M-8B2A

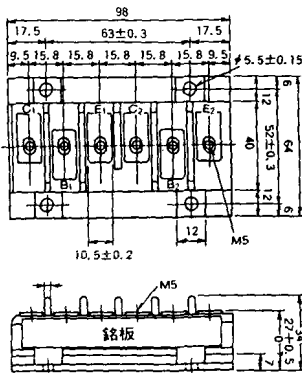

M-9A1A

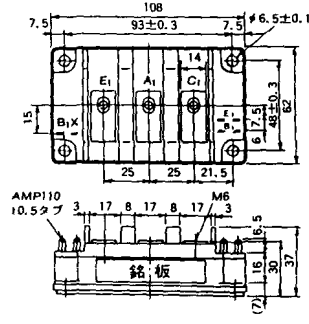

M-9A2A

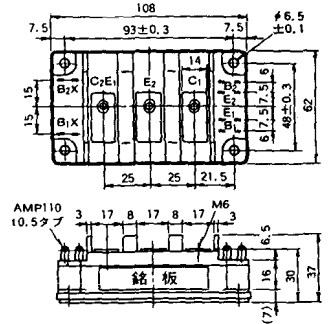

《寸法図単位:mm》

<http://store.iic.cc/>







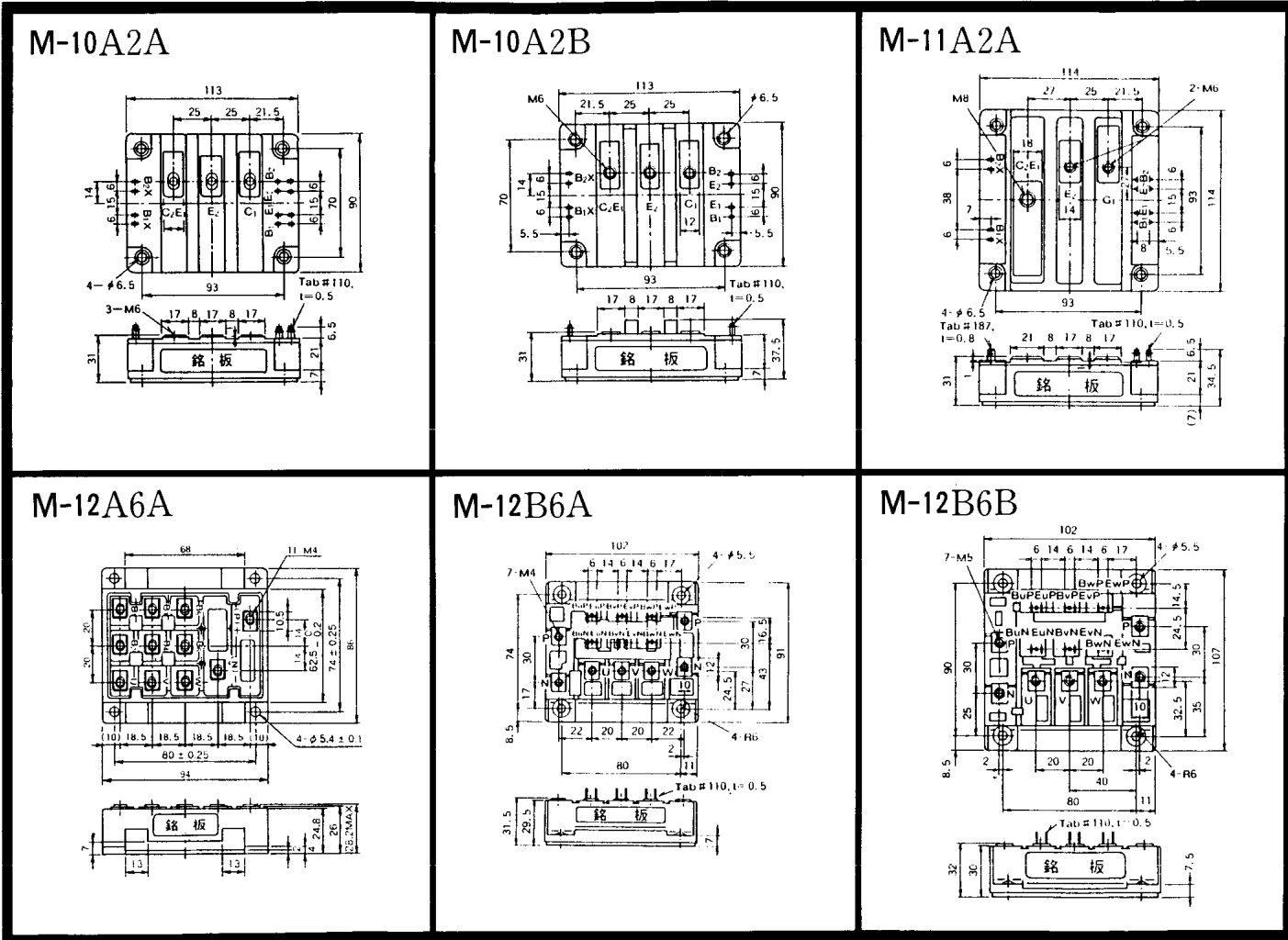

《寸法図単位：mm》

<http://store.iicc.cc/>

M-4A2D

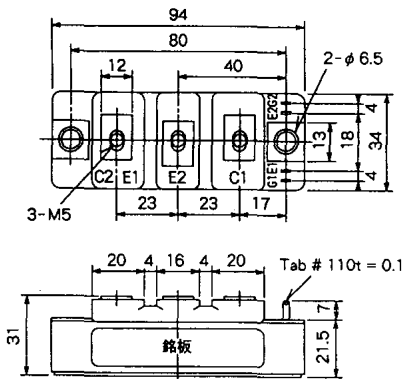

M-4A2E

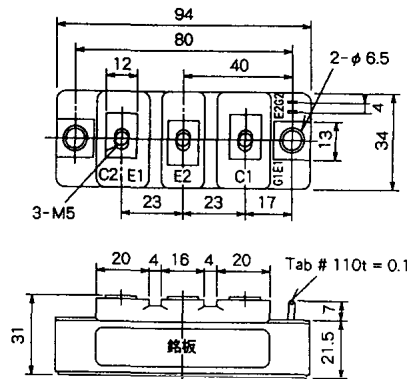

M-4C2A

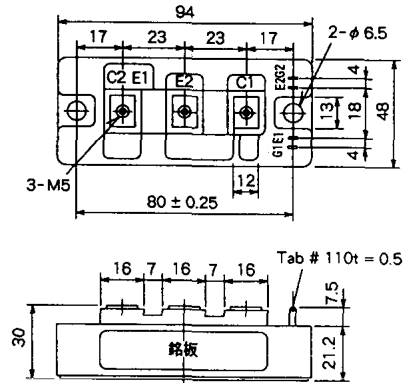

M-4C2B

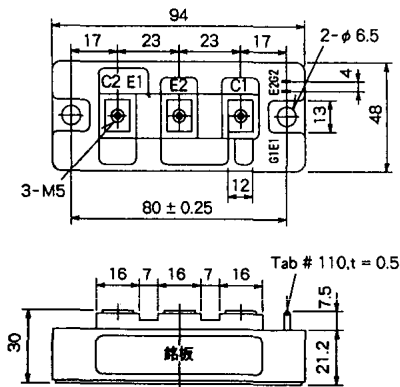

M-9B1C

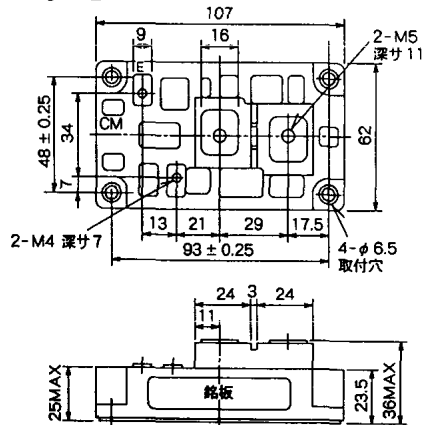

M-9D2A

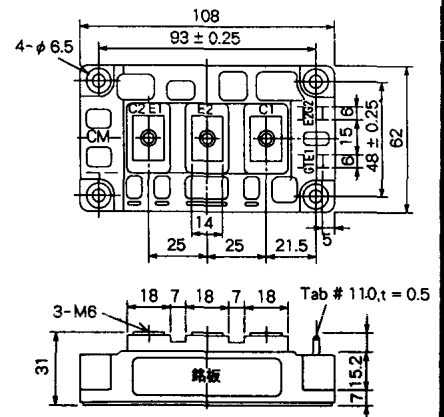

〈寸法図単位：mm〉

<http://store.iic.cc/>

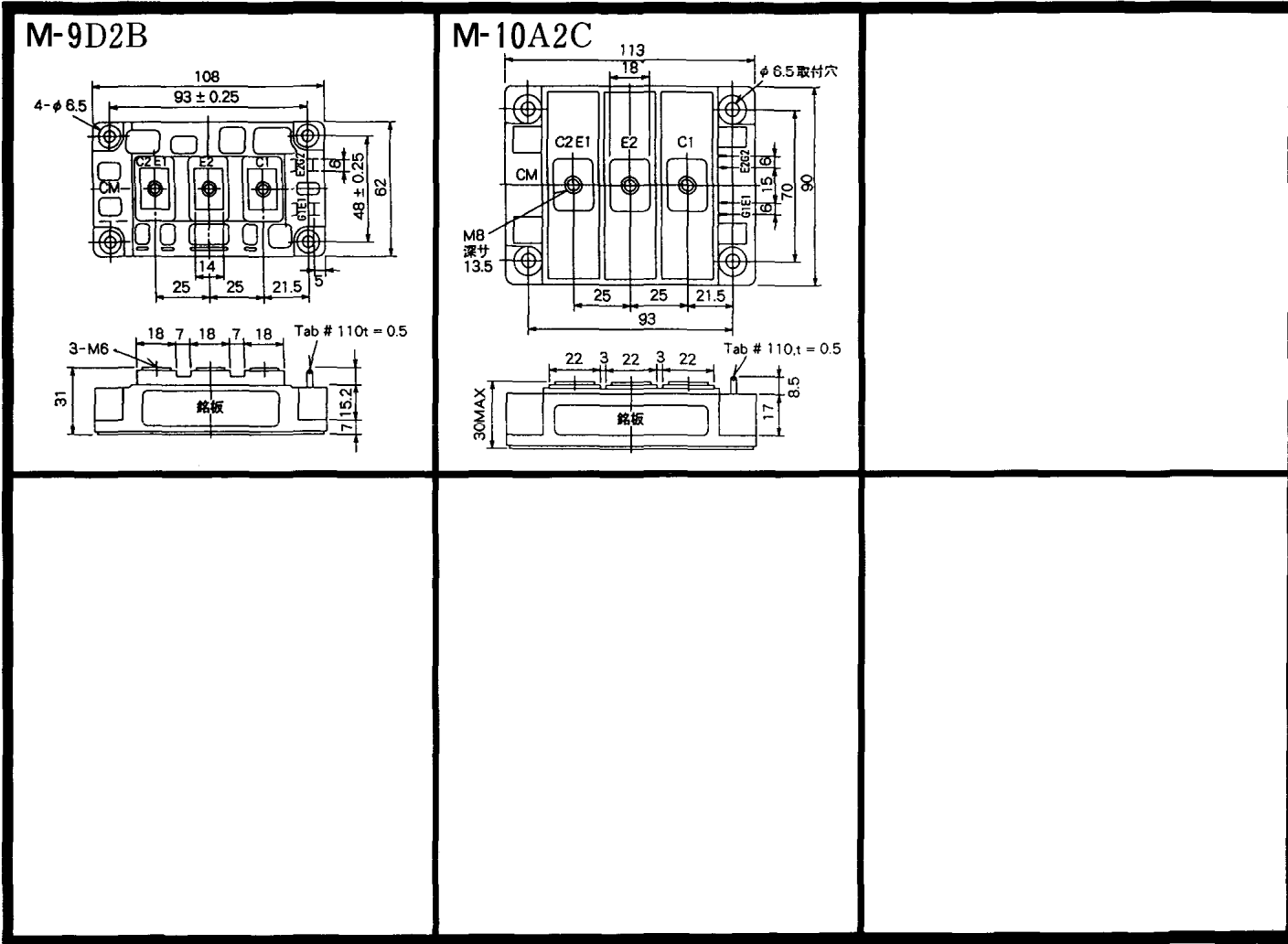

〈寸法図単位：mm〉

<http://store.iic.cc/>

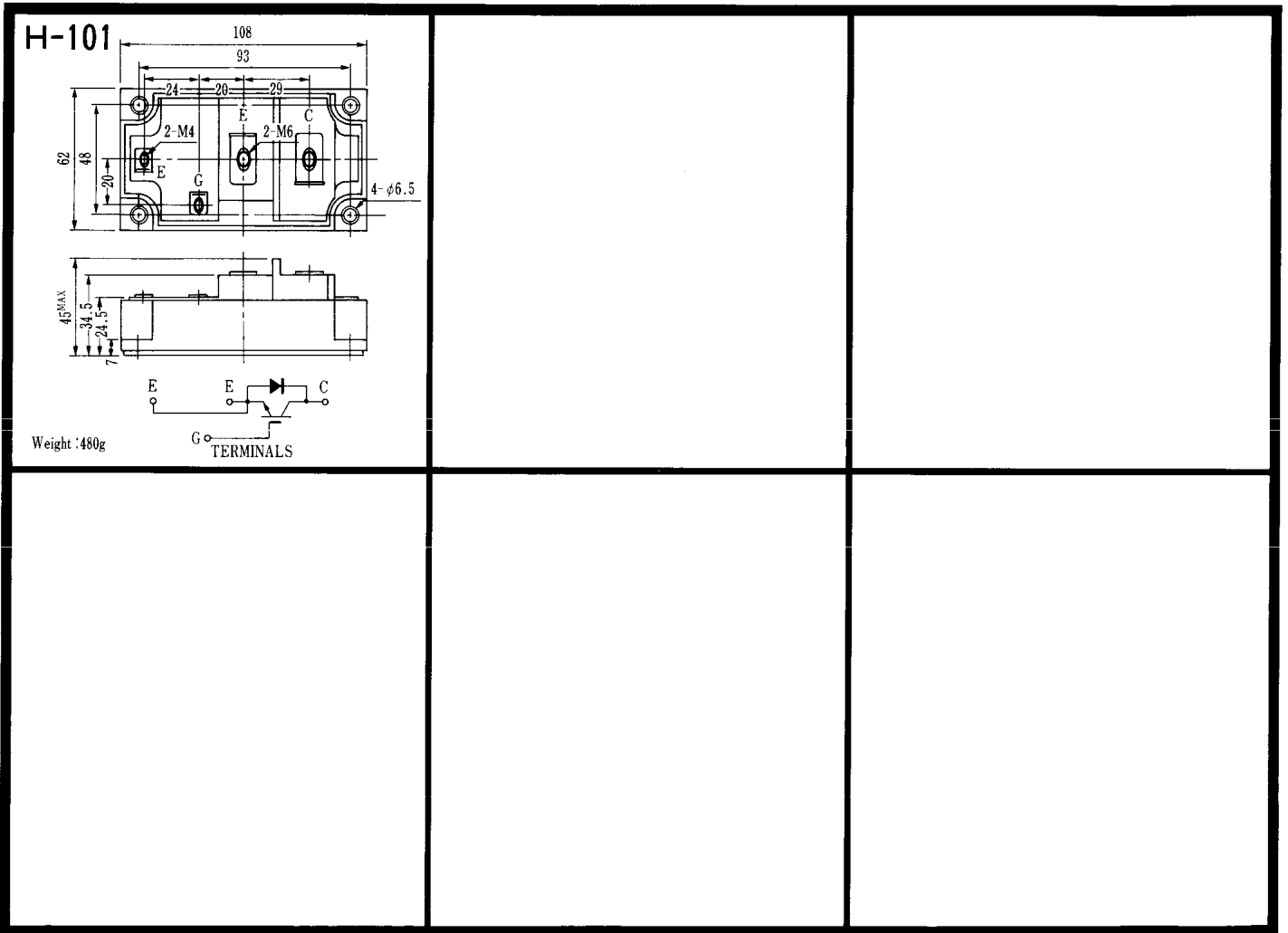

<http://store.iic.cc/>

《寸法图单位:mm》

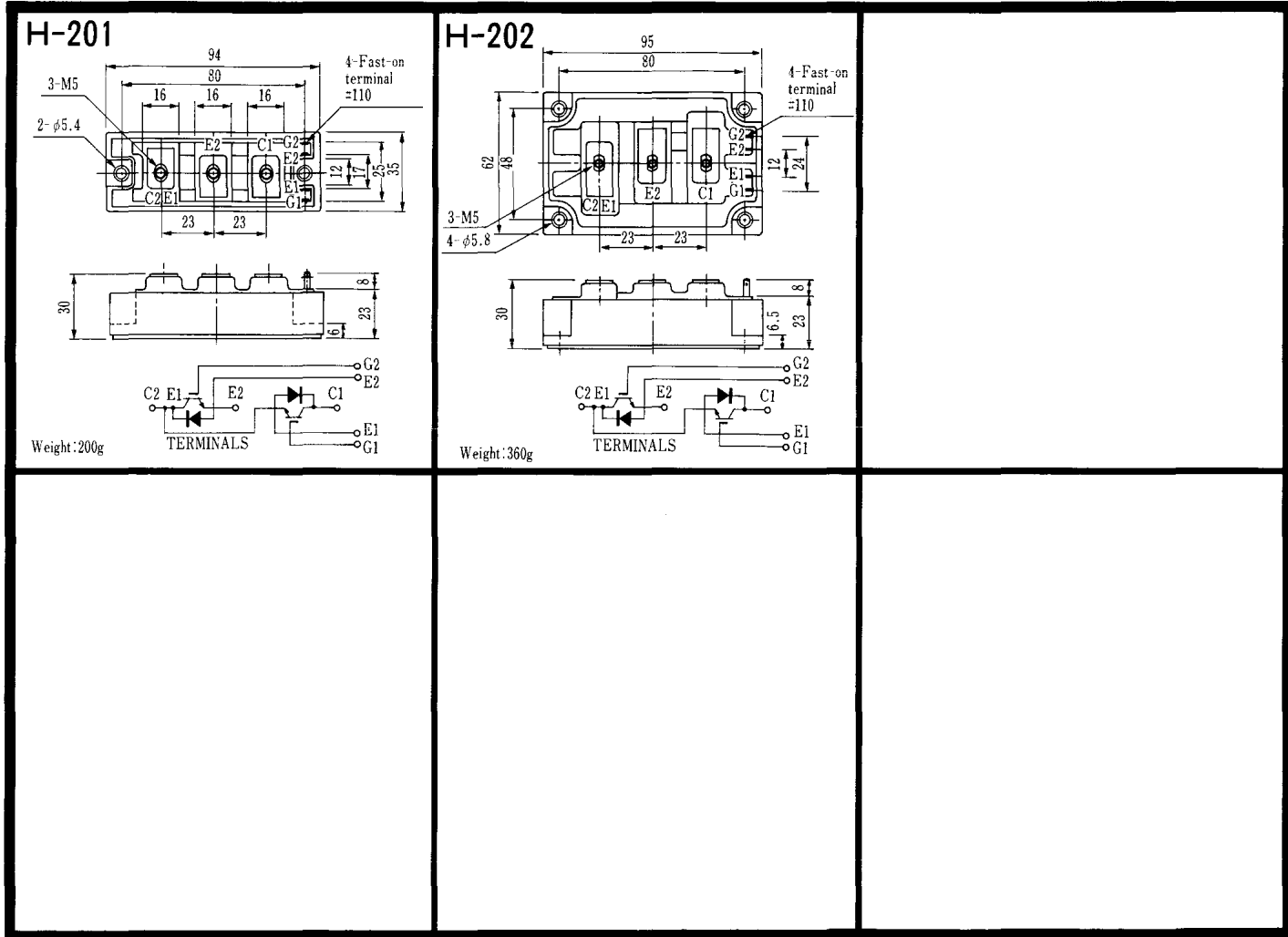

〈寸法図単位:mm〉

<http://store.iic.cc/>

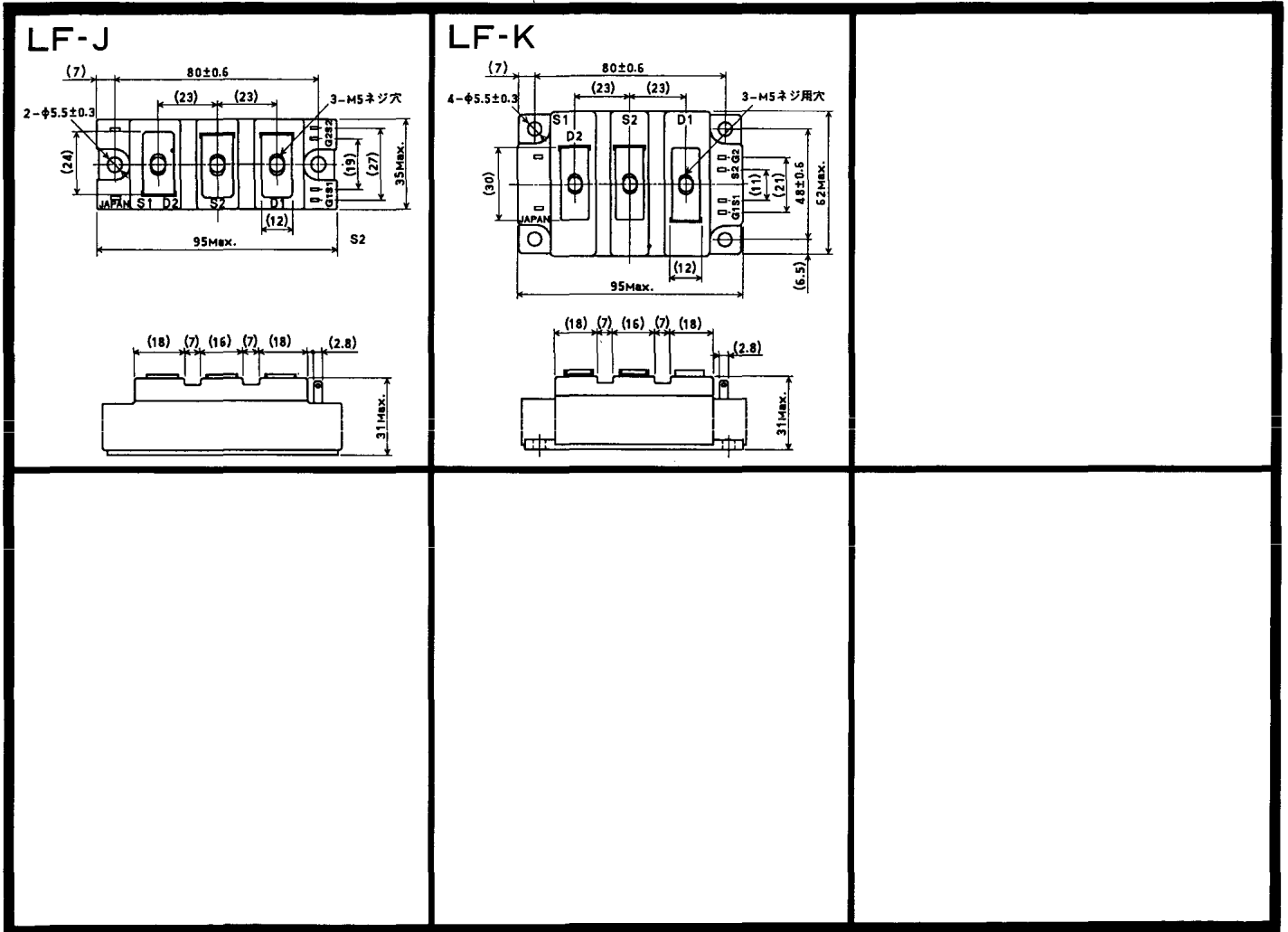

〈寸法図単位：mm〉

<http://store.iic.cc/>

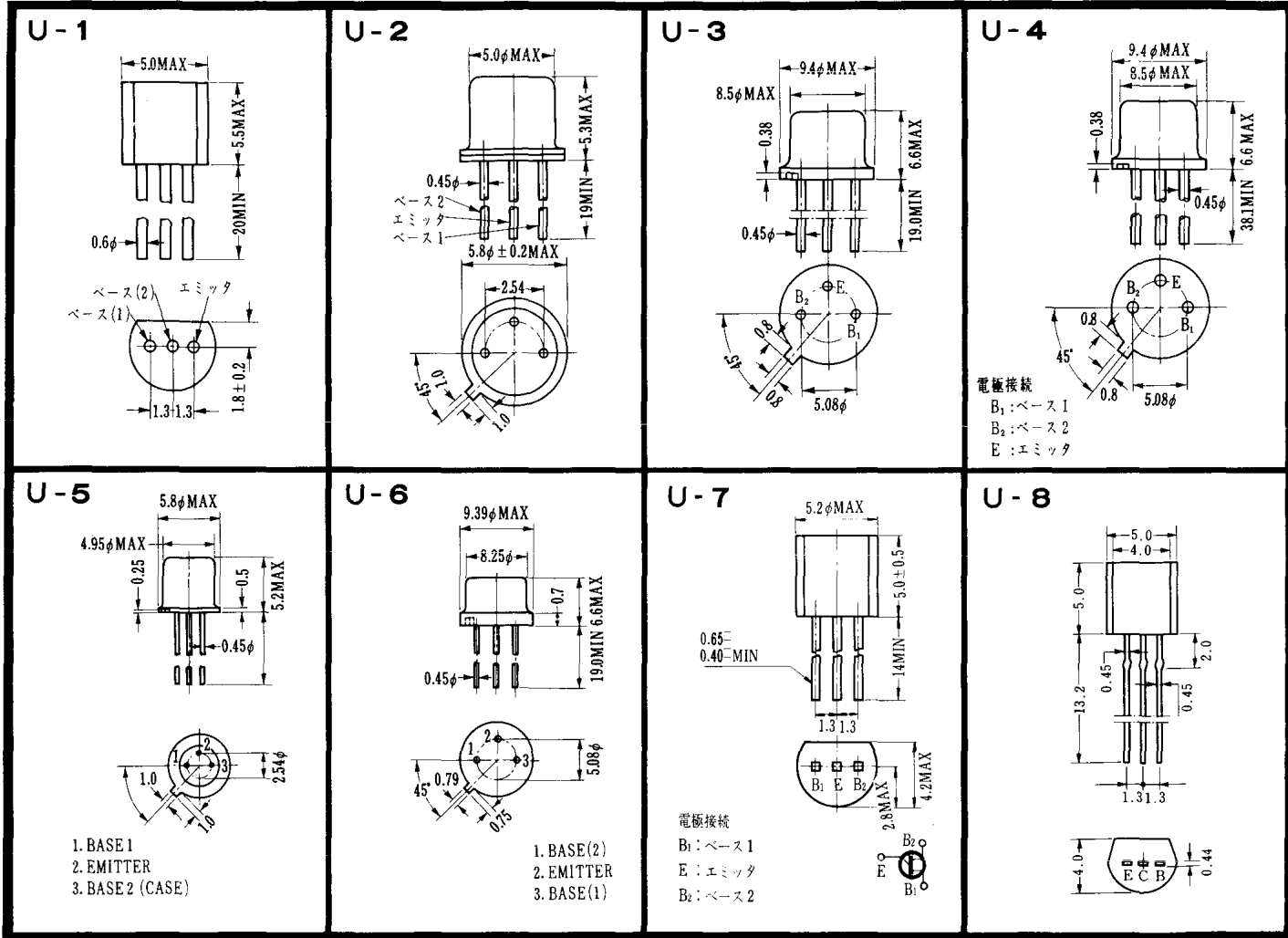

〈寸法図単位: mm〉

<http://store.iic.cc/>