



WESTCODE SEMICONDUCTORS

Technical
Publication
TN370C
Issue 4
April 1988

Convertor Grade Capsule Thyristor Type N370C

880 amperes average: up to 1500 volts V_{RRM}

Ratings (Maximum values at 125°C T_j unless stated otherwise)

RATING	CONDITIONS	SYMBOL	
Average on-state current	Half sine wave $\left\{ \begin{array}{l} 55^\circ\text{C heatsink temperature} \\ \text{(double side cooled)} \\ 85^\circ\text{C heatsink temperature} \\ \text{(single side cooled)} \end{array} \right.$	$I_{T(AV)}$	880A 337A
R.M.S. on-state current	25°C heatsink temperature, double side cooled	$I_T(RMS)$	1780A
Continuous on-state current	25°C heatsink temperature, double side cooled	I_T	1500A
Peak one-cycle surge (non-repetitive) on state current	10ms duration, 60% V_{RRM} re-applied	$I_{TSM(1)}$	12700A
	10ms duration, $V_R \leq 10$ volts	$I_{TSM(2)}$	14000A
Maximum permissible surge energy	10ms duration, $V_R \leq 10$ volts	$I^2t(2)$	975000A ² s
	3ms duration, $V_R \leq 10$ volts	I^2t	720000A ² s
Peak forward gate current	Anode positive with respect to cathode	I_{FGM}	20A
Peak forward gate voltage	Anode positive with respect to cathode	V_{FGM}	22V
Peak reverse gate voltage		V_{RGM}	5V
Average gate power		P_G	4W
Peak gate power	100μs. pulse width	P_{GM}	120W
Rate of rise of off-state voltage	To 80% V_{DRM} gate open-circuit	dv/dt	*200V/μs
Rate of rise of on-state current (repetitive)	$\left\{ \begin{array}{l} \text{Gate drive 20 volts, 20 ohms with } t_r \leq 1\mu\text{s.} \\ \text{Anode voltage } \leq 80\% V_{DRM} \end{array} \right.$	$di/dt(1)$	500A/μs
Rate of rise of on-state current (non-repetitive)		$di/dt(2)$	1000A/μs
Operating temperature range		T_{hs}	-40 + 125°C
Storage temperature range		T_{stg}	-40 + 150°C

Characteristics (Maximum values at 125°C T_j unless stated otherwise)

CHARACTERISTIC	CONDITIONS	SYMBOL	
Peak on-state voltage	At 1700A, I_{TM}	V_{TM}	1.59V
Forward conduction threshold voltage		V_O	1.06V
Forward conduction slope resistance		r	0.31mΩ
Repetitive peak off-state current	At V_{DRM}	I_{DRM}	60mA
Repetitive peak reverse current	At V_{RRM}	I_{RRM}	60mA
Maximum gate current required to fire all devices	$\left\{ \begin{array}{l} V_A = 6V, I_A = 2A, \text{ at } 25^\circ\text{C } T_j \end{array} \right.$	I_{GT}	300mA
Maximum gate voltage required to fire all devices		V_{GT}	3V
Maximum holding current		I_H	1A
Maximum gate voltage which will not trigger any device		V_{GD}	0.25V
Thermal resistance, junction to heatsink, for a device with a maximum forward volt drop characteristic	Double side cooled Single side cooled	$R_{th(j-hs)}$	0.044°C/W 0.088°C/W

VOLTAGE CODE		H02	H04	H06	H08	H10	H12	H14	H15
Repetitive peak voltages	$V_{RRM} V_{DRM}$	200	400	600	800	1000	1200	1400	1500
Non-repetitive peak off-state voltage	V_{DSM}	200	400	600	800	1000	1200	1400	1500
Non-repetitive peak reverse blocking voltage	V_{RSM}	300	500	700	900	1100	1300	1500	1600

Ordering Information (Please quote device code as explained below – 8 digits)

N 3 7 0 C	● ● ●	Typical code: N370CH12 = 1200 V_{RRM} 1200 V_{DRM} , 200 V/μs. dv/dt to 80% V_{DRM}
	Voltage code (see ratings)	

* Other values of dv/dt may be available.

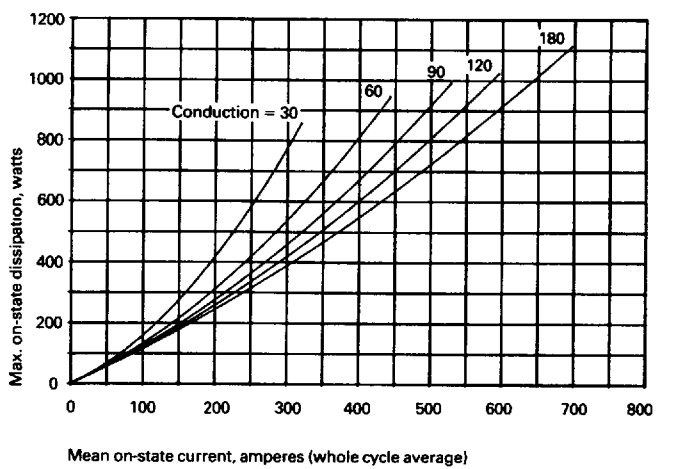
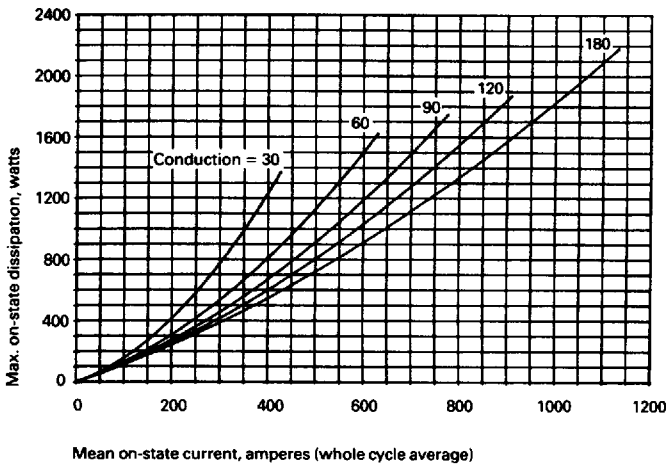
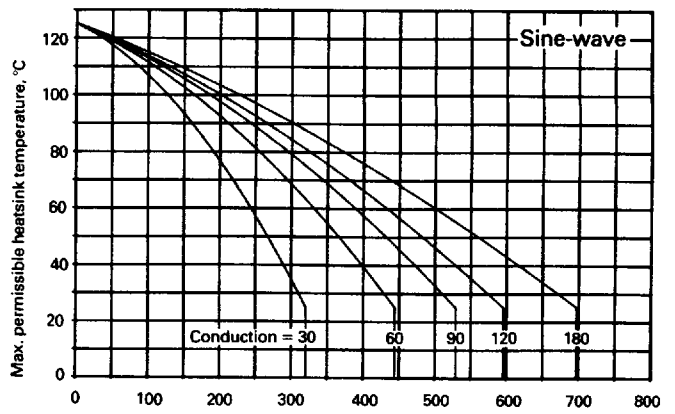
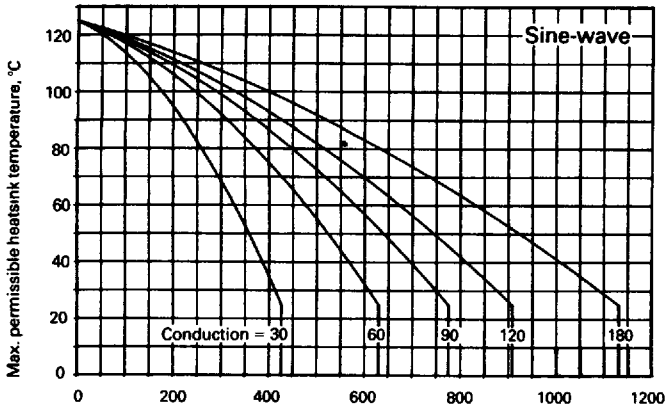

Figure 1 Dissipation and heatsink temperature v. current (Double side cooled)

Figure 2 Dissipation and heatsink temperature v. current (Single side cooled)

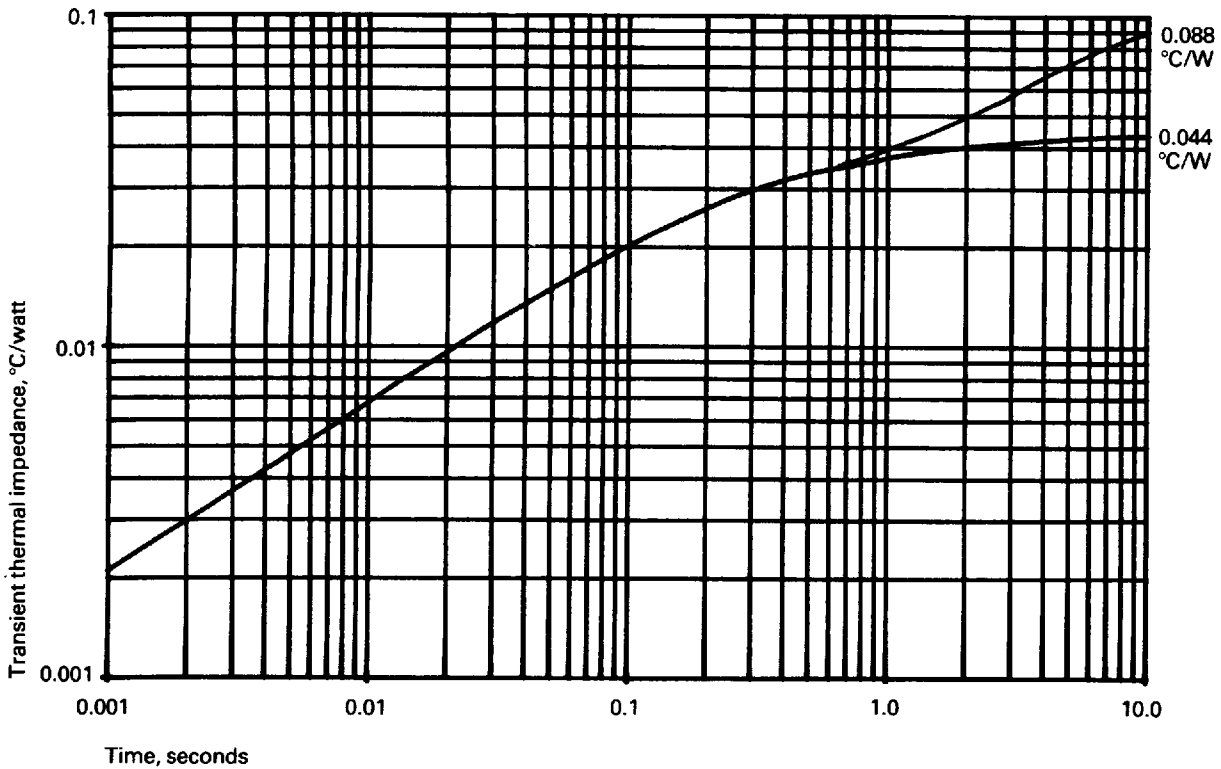

Figure 3 Junction to heatsink thermal impedance

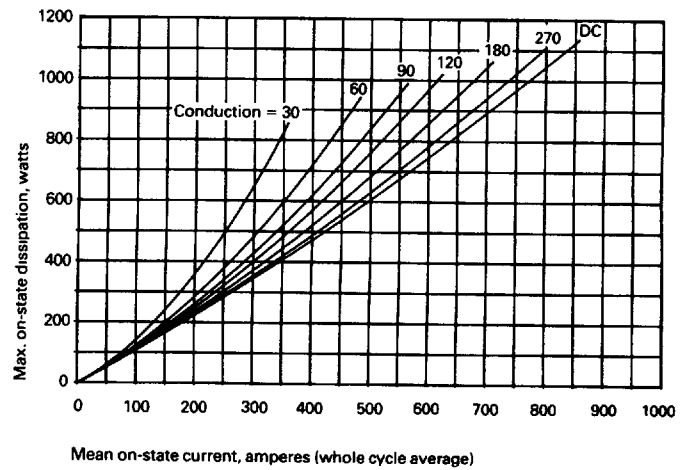
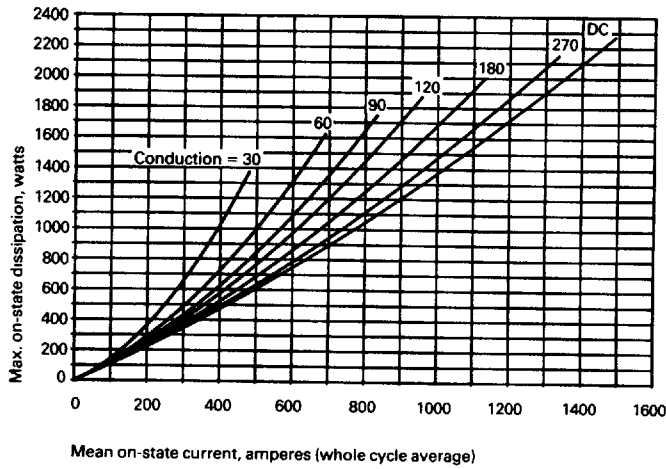
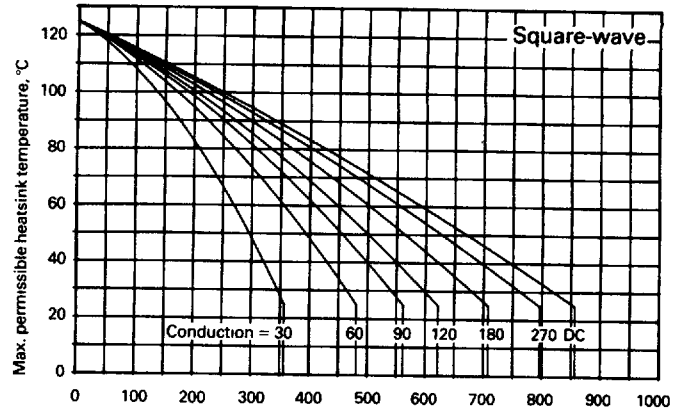
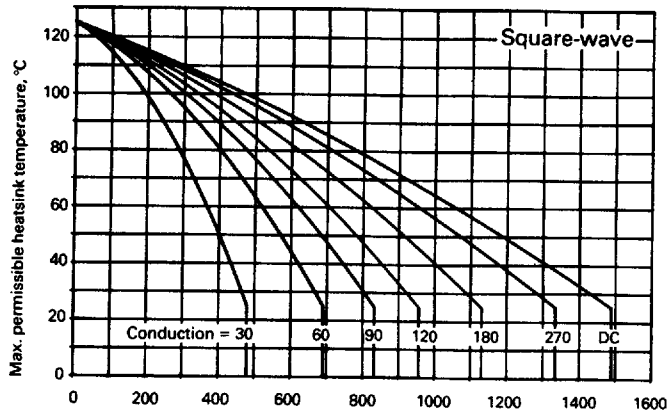

Figure 4 Dissipation and heatsink temperature v. current (Double side cooled)

Figure 5 Dissipation and heatsink temperature v. current (Single side cooled)

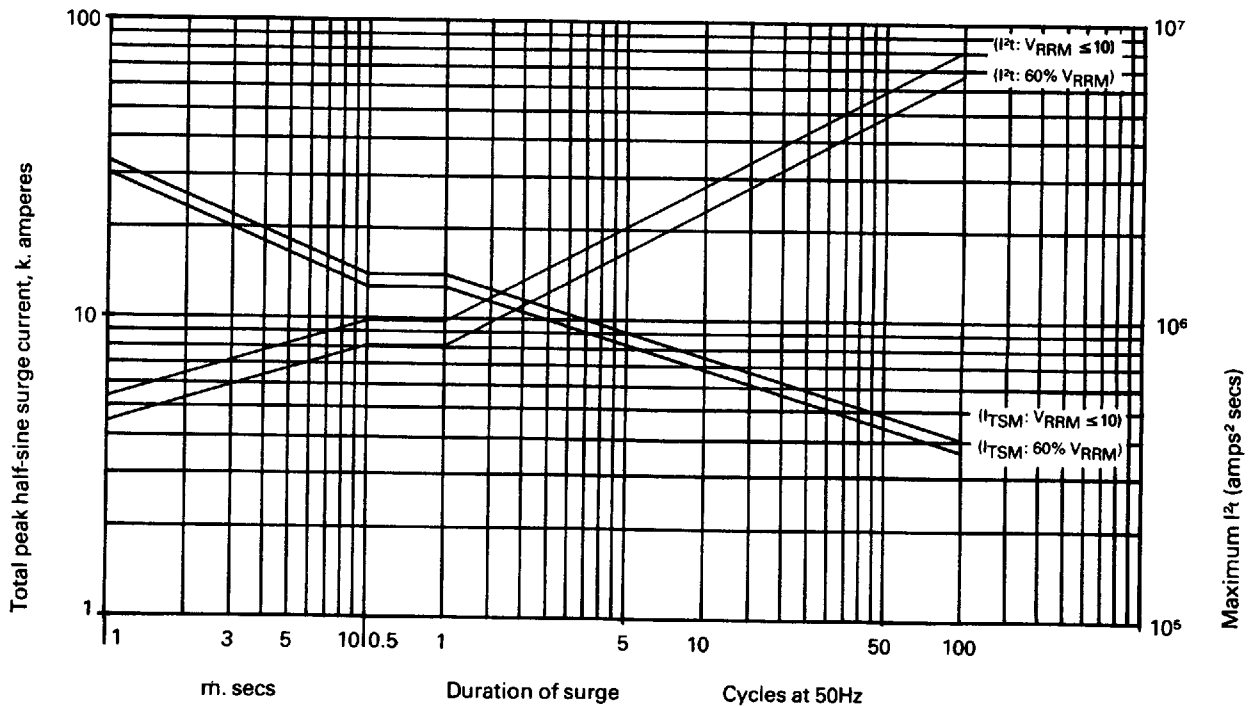

Figure 6 Max. non-repetitive surge current at initial junction temperature 125°C.
 (gate may temporarily lose control of firing angle)
 Note: This rating must not be interpreted as an intermittent rating

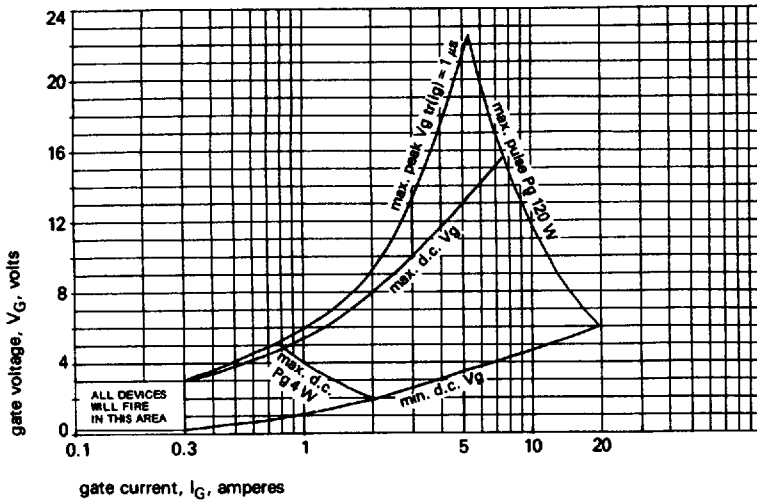

Figure 7 Gate characteristics at 25°C junction temperature

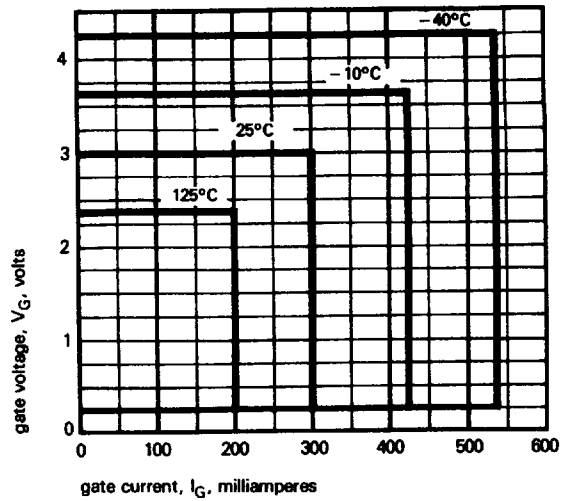

Figure 8 Gate triggering characteristics
Trigger points of all thyristors lie within the areas shown

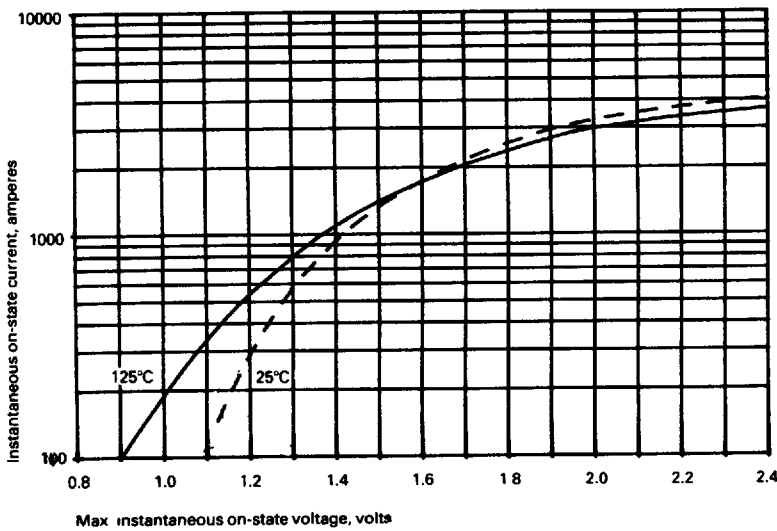
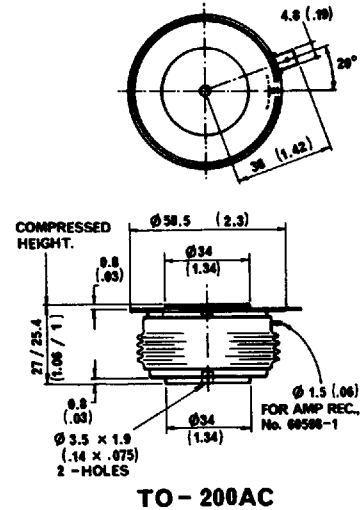

Figure 9 Limit on-state characteristic



Dimensions in mm (inches)
Mounting force: 1000-2000 Kg
Weight: 340 grams

In the interest of product improvement, Westcode reserves the right to change specifications at any time without notice.

WESTCODE SEMICONDUCTORS LIMITED
P.O. Box 57, Chippenham,
Wiltshire, England SN15 1JL
Telephone: (Sales) 0249 444524
Telex: 44751 Telefax: 0249 659448

HAWKER SIDDELEY
Westinghouse Brake and Signal Co. Ltd.