

SEMIPACK[®] 4
Fast Diode Modules

SKKE 400 F



Features

- Heat transfer through aluminium nitride ceramic isolated metal baseplate
- Precious metal pressure contacts for high reliability
- Small recovered charge
- Soft recovery
- Up to 1800 V reverse voltage
- UL recognized, file no. E 63 532

Typical Applications

- Inverse diodes for GTO and fast thyristors
- Inverters and choppers
- AC motor control
- Inductive heating
- Uninterruptible power supplies (UPS)

V_{RSM} V_{RRM}	I_{FRMS} (maximum value for continuous operation) 660 A
V	I_{FAV} (sin. 180; $T_{case} = 85\text{ °C}$; 50 Hz) 420 A
800	SKKE 400 F 08
1200	SKKE 400 F 12
1400	SKKE 400 F 14
1600	SKKE 400 F 16
1800	SKKE 400 F 18

Symbol	Conditions	SKKE 400 F
I_{FAV}	sin. 180; $T_{case} = 89\text{ °C}$; $f = 2000\text{ Hz}$	400 A
	sin. 180; $R_{thha} = 0,05\text{ °C/W}$; $f = 2000\text{ Hz}$; $T_{amb} = 45\text{ °C}$	400 A
I_{FSM}	$T_{vj} = 25\text{ °C}$; 10 ms	12 000 A
	$T_{vj} = 150\text{ °C}$; 10 ms	11 000 A
i^2t	$T_{vj} = 25\text{ °C}$; 8,3 ... 10 ms	720 000 A ² s
	$T_{vj} = 150\text{ °C}$; 8,3 ... 10 ms	605 000 A ² s
Q_{rr} I_{RM}	$\left\{ \begin{array}{l} T_{vj} = 150\text{ °C}; I_{FM} = 400\text{ A}; \\ - diF/dt = 100\text{ A}/\mu\text{s}; V_R = 100\text{ V} \end{array} \right.$	200 μC
		160 A
I_{RD}	$T_{vj} = 25\text{ °C}$; $V_{RD} = V_{RRM}$	4 mA
	$T_{vj} = 150\text{ °C}$; $V_{RD} = V_{RRM}$	30 mA
V_F	$T_{vj} = 25\text{ °C}$; $I_{FM} = 1800\text{ A}$; max.	2,05 V
$V_{(TO)}$	$T_{vj} = 150\text{ °C}$	0,95 V
r_T	$T_{vj} = 150\text{ °C}$	0,65 m Ω
R_{thjc}	sin. 180	0,095 °C/W
R_{thch}		0,02 °C/W
T_{vj}		- 40 ... +150 °C
T_{stg}		- 40 ... +130 °C
V_{isol}	a. c. 50 Hz; r.m.s; 1 s/1 min.	3600/3000 V~
M_1 M_2	$\left. \begin{array}{l} \text{Case to heatsink} \\ \text{Busbars to terminals} \end{array} \right\} \text{SI units/US units}$	5 Nm/44 lb. in. $\pm 15\%^{1)}$
		17 Nm/150 lb. in. $\pm 15\%^{2)}$
a		5 · 9,81 m/s ²
w	approx.	950 g
Case		A 42

1) See the assembly instructions
2) The screws must be lubricated

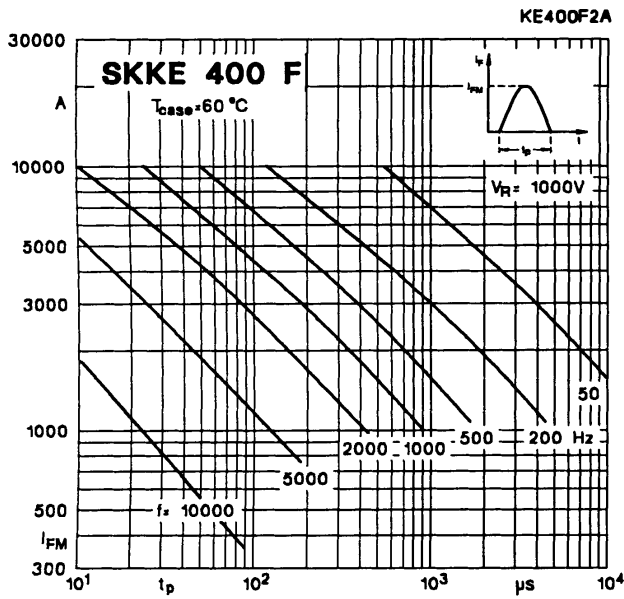

Fig. 12 a Rated sinusoidal peak forward current

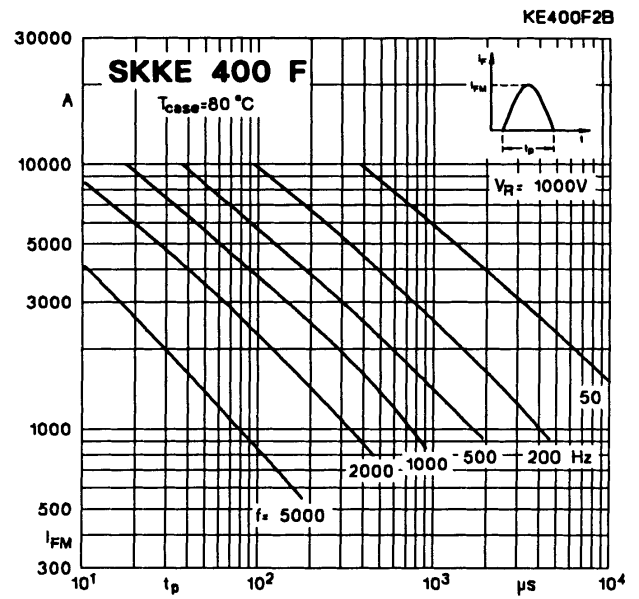

Fig. 12 b Rated sinusoidal peak forward current

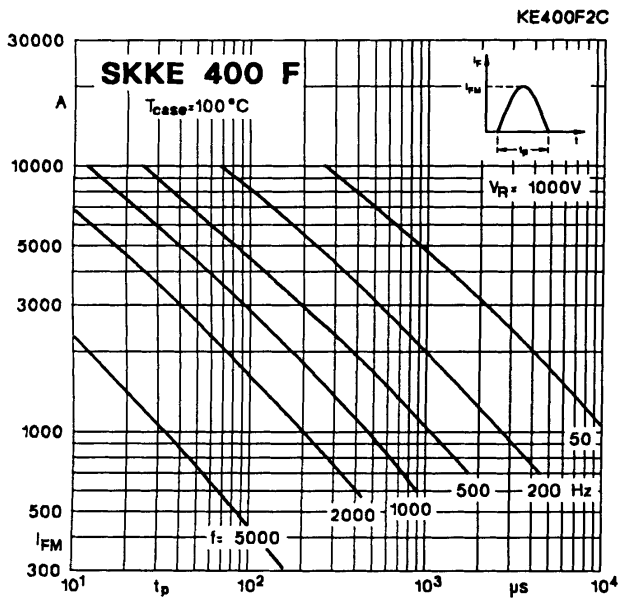

Fig. 12 c Rated sinusoidal peak forward current

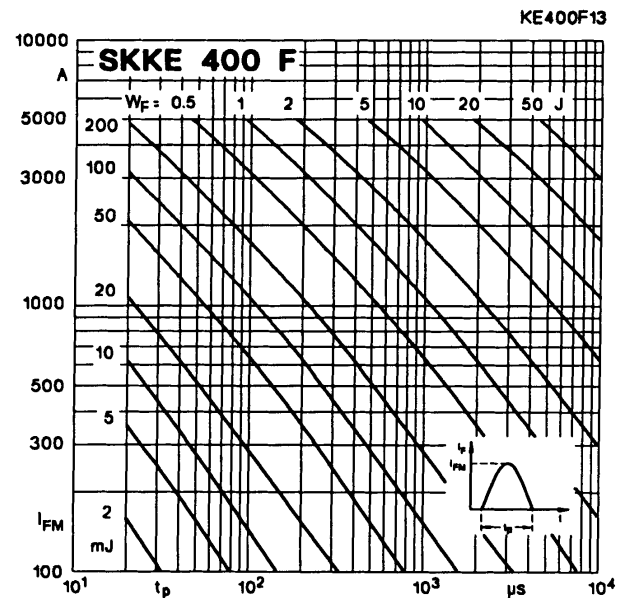

Fig. 13 Forward energy dissipation, sinusoidal

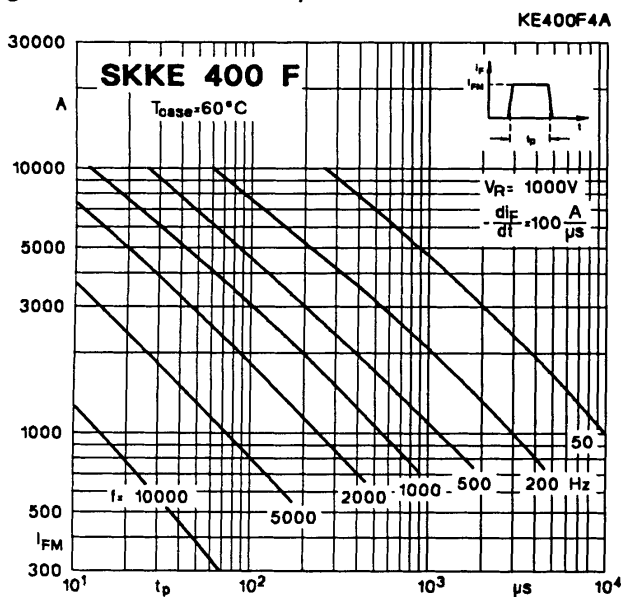

Fig. 14 a Rated rectangular peak forward current

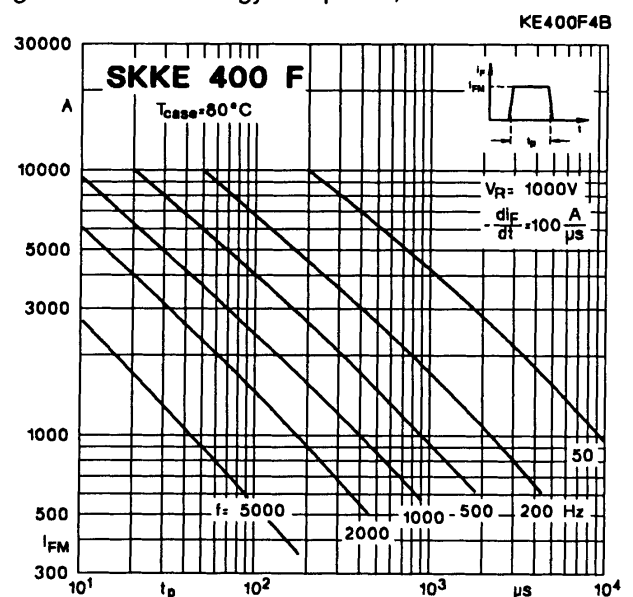

Fig. 14 b Rated rectangular peak forward current

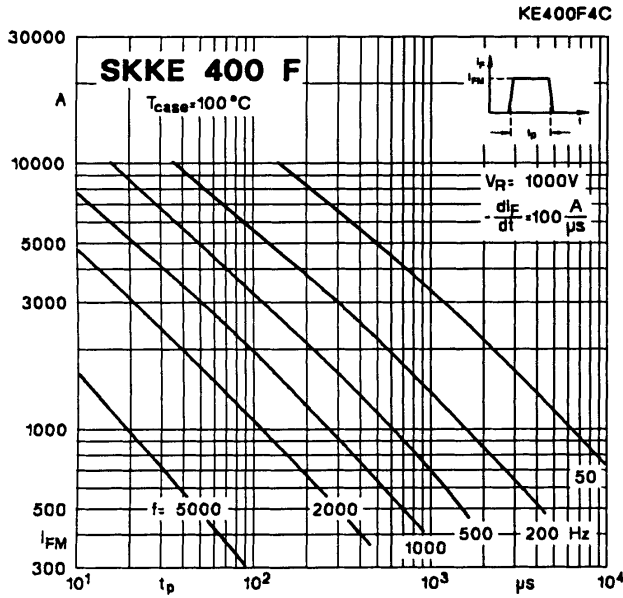

Fig. 14 c Rated rectangular peak forward current

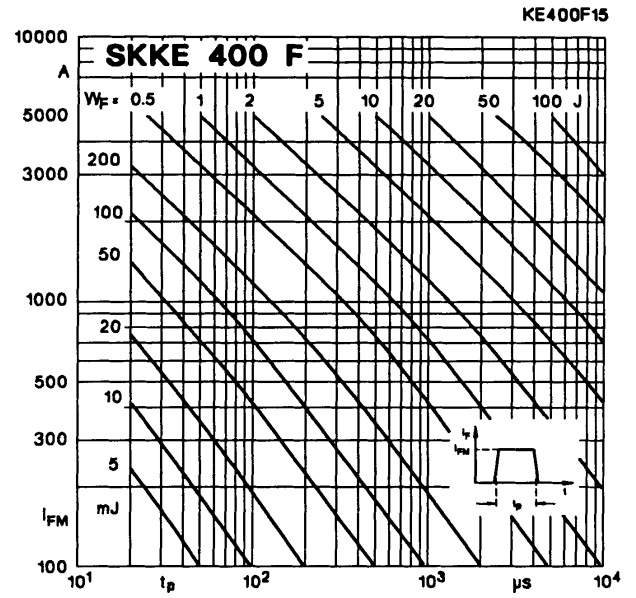

Fig. 15 Forward energy dissipation, rectangular

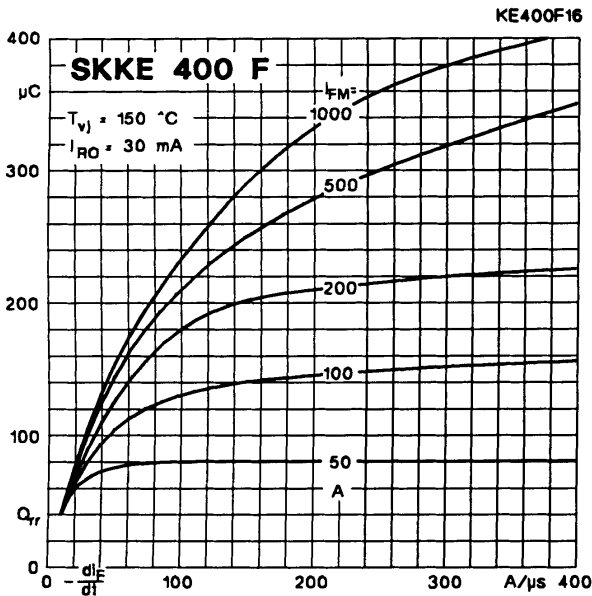

Fig. 16 Recovered charge vs. current decrease

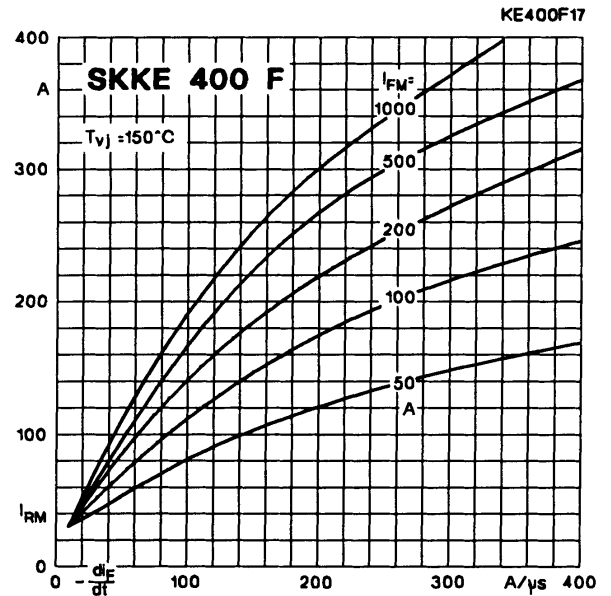

Fig. 17 Peak recovery current vs. current decrease

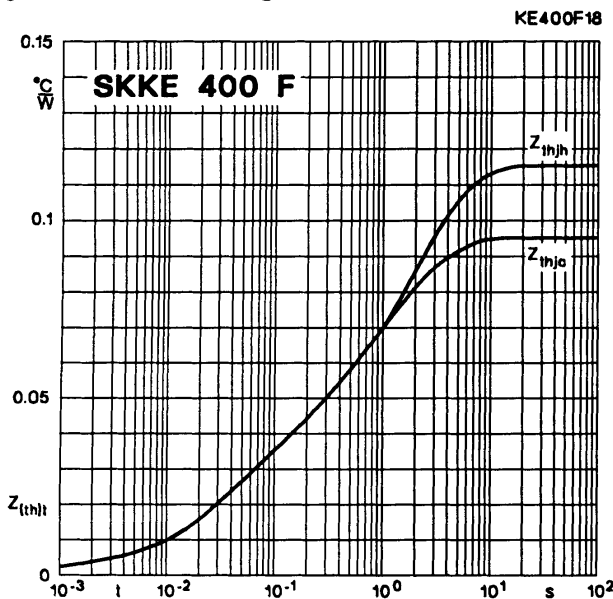

Fig. 18 Transient thermal impedance vs. time

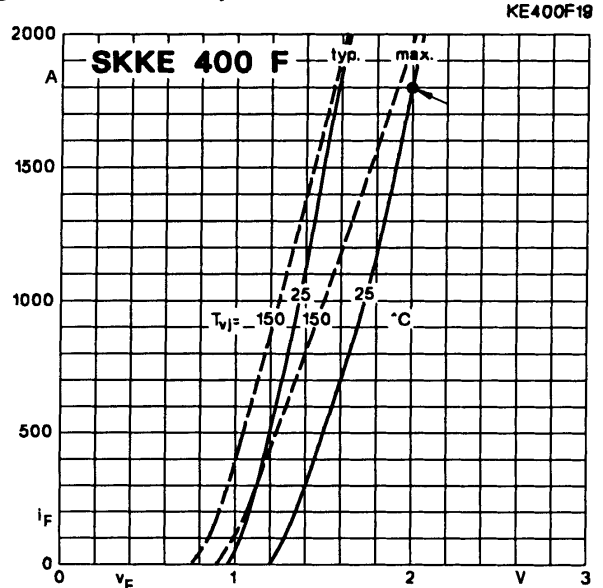

Fig. 19 Forward characteristics

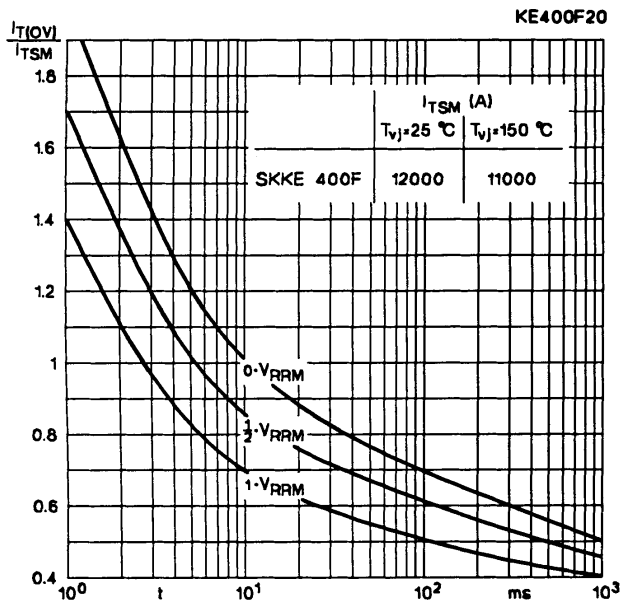
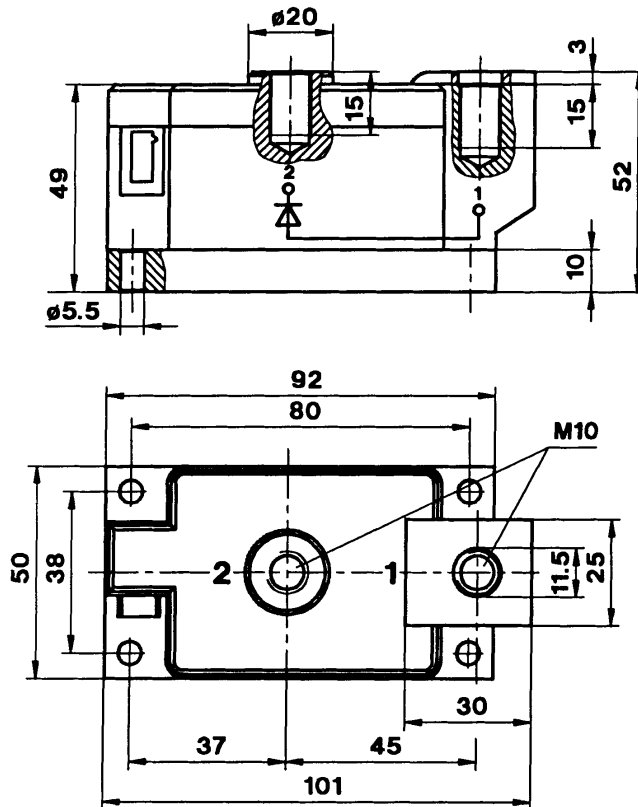

Fig. 20 Surge overload current vs. time

SKKE 400 F
Case A 42



Dimensions in mm