

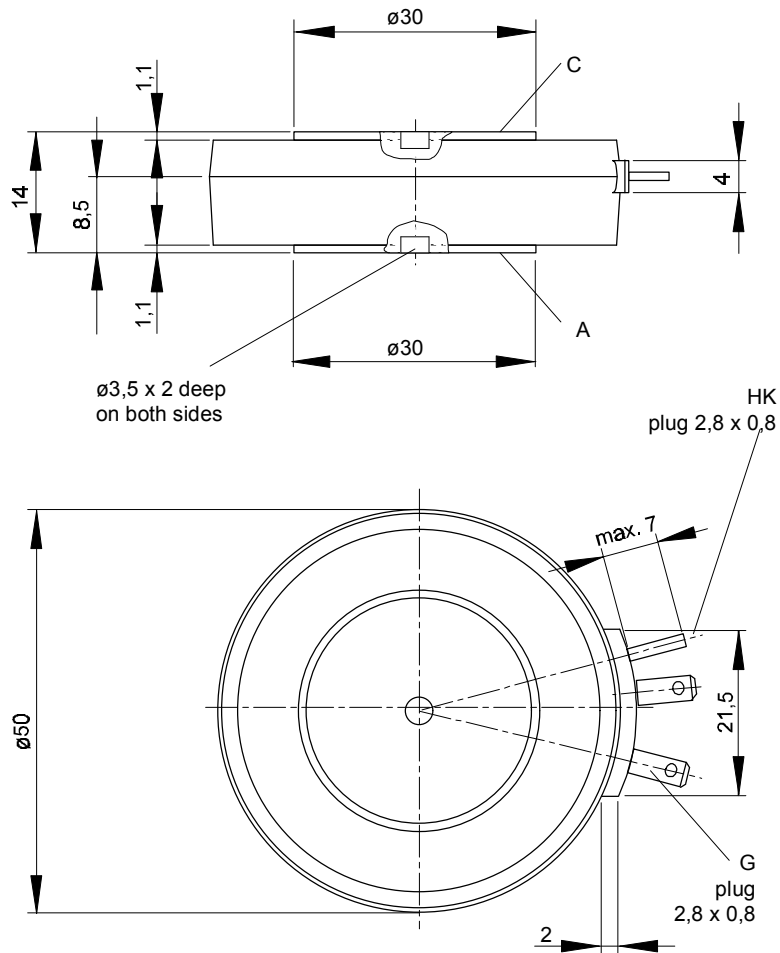

European Power-Semiconductor and Electronics Company

Marketing Information

T 388 N



T 388 N

Elektrische Eigenschaften

Höchstzulässige Werte

Periodische Vorwärts- und Rückwärts-Spitzensperrspannung

Electrical properties

Maximum rated values

repetitive peak forward off-state and reverse voltages

$$t_{vj} = -40^{\circ}\text{C} \dots t_{vj \text{ max}}$$

$$V_{\text{DRM}}, V_{\text{RRM}} \quad 600 \ 800 \ 1000 \ 1200 \quad \text{V}$$

$$1400 \ 1600 \ 1800^*$$

Vorwärts-Stoßspitzensperrspannung

non-repetitive peak forward off-state voltage

$$t_{vj} = -40^{\circ}\text{C} \dots t_{vj \text{ max}}$$

$$V_{\text{DSM}} = V_{\text{DRM}} \quad 600 \ 800 \ 1000 \ 1200 \quad \text{V}$$

$$1400 \ 1600 \ 1800^*$$

Rückwärts-Stoßspitzensperrspannung

non-repetitive peak reverse voltage

$$t_{vj} = +25^{\circ}\text{C} \dots t_{vj \text{ max}}$$

$$V_{\text{RSM}} = V_{\text{RRM}} \quad 700 \ 900 \ 1100 \ 1300 \quad \text{V}$$

$$1500 \ 1700 \ 1900$$

Durchlaßstrom-Grenzeffektivwert

RMS on-state current

$$I_{\text{TRMSM}} \quad 730 \quad \text{A}$$

Dauergrenzstrom

average on-state current

$$t_c = 85^{\circ}\text{C}$$

$$I_{\text{TAVM}} \quad 388 \quad \text{A}$$

$$t_c = 72^{\circ}\text{C}$$

$$465 \quad \text{A}$$

Stoßstrom-Grenzwert

surge current

$$t_{vj} = 25^{\circ}\text{C}, t_p = 10 \text{ ms}$$

$$I_{\text{TSM}} \quad 7200 \quad \text{A}$$

$$t_{vj} = t_{vj \text{ max}}, t_p = 10 \text{ ms}$$

$$6400 \quad \text{A}$$

Grenzlastintegral

$I^2 t$ -value

$$t_{vj} = 25^{\circ}\text{C}, t_p = 10 \text{ ms}$$

$$I^2 t \quad 260000 \quad \text{A}^2\text{s}$$

$$t_{vj} = t_{vj \text{ max}}, t_p = 10 \text{ ms}$$

$$205000 \quad \text{A}^2\text{s}$$

Kritische Stromsteilheit

critical rate of rise of on-state current

$$V_D \leq 67\%, V_{\text{DRM}}, f = 50 \text{ Hz}$$

$$(di_T/dt)_{\text{cr}} \quad 120 \quad \text{A}/\mu\text{s}$$

$$V_L = 10 \text{ V}, i_{\text{GM}} = 1 \text{ A}, di_G/dt = 1 \text{ A}/\mu\text{s}$$

Kritische Spannungssteilheit

critical rate of rise of off-state voltage

$$t_{vj} = t_{vj \text{ max}}, V_D = 67\% V_{\text{DRM}}$$

$$(dv/dt)_{\text{cr}} \quad 1000 \quad \text{V}/\mu\text{s}$$

Charakteristische Werte

Characteristic values

Durchlaßspannung

on-state voltage

$$t_{vj} = t_{vj \text{ max}}, i_T = 1500 \text{ A}$$

$$V_T \quad \text{max. } 2,1 \quad \text{V}$$

Schleusenspannung

threshold voltage

$$t_{vj} = t_{vj \text{ max}}$$

$$V_{T(\text{TO})} \quad 0,9 \quad \text{V}$$

Ersatzwiderstand

slope resistance

$$t_{vj} = t_{vj \text{ max}}$$

$$r_T \quad 0,75 \quad \text{m}\Omega$$

Zündstrom

gate trigger current

$$t_{vj} = 25^{\circ}\text{C}, V_D = 6 \text{ V}$$

$$I_{\text{GT}} \quad \text{max. } 200 \quad \text{mA}$$

Zündspannung

gate trigger voltage

$$t_{vj} = 25^{\circ}\text{C}, V_D = 6 \text{ V}$$

$$V_{\text{GT}} \quad \text{max. } 2 \quad \text{V}$$

Nicht zündender Steuerstrom

gate non-trigger current

$$t_{vj} = t_{vj \text{ max}}, V_D = 6 \text{ V}$$

$$I_{\text{GD}} \quad \text{max. } 10 \quad \text{mA}$$

Nicht zündende Steuerspannung

gate non-trigger voltage

$$t_{vj} = t_{vj \text{ max}}, V_D = 0,5 V_{\text{DRM}}$$

$$V_{\text{GD}} \quad \text{max. } 0,2 \quad \text{V}$$

Haltestrom

holding current

$$t_{vj} = 25^{\circ}\text{C}, V_D = 6 \text{ V}, R_A = 5 \Omega$$

$$I_H \quad \text{max. } 300 \quad \text{mA}$$

Einraststrom

latching current

$$t_{vj} = 25^{\circ}\text{C}, V_D = 6 \text{ V}, R_{\text{GK}} \geq 10 \Omega$$

$$I_L \quad \text{max. } 1,2 \quad \text{A}$$

$$i_{\text{GM}} = 1 \text{ A}, di_G/dt = 1 \text{ A}/\mu\text{s}, t_g = 20 \mu\text{s}$$

Vorwärts- und Rückwärts-Sperrstrom

forward off-state and reverse currents

$$t_{vj} = t_{vj \text{ max}}, V_D = V_{\text{DRM}}, V_R = V_{\text{RRM}}$$

$$i_D, i_R \quad \text{max. } 50 \quad \text{mA}$$

Zündverzug

gate controlled delay time

$$t_{vj} = 25^{\circ}\text{C}, i_{\text{GM}} = 1 \text{ A}, di_G/dt = 1 \text{ A}/\mu\text{s}$$

$$t_{\text{gd}} \quad \text{max. } 4 \quad \mu\text{s}$$

Freiwerdezeit

circuit commutated turn-off time

siehe Techn.Erl./see Techn. Inf.

$$t_q \quad \text{typ. } 220 \quad \mu\text{s}$$

Thermische Eigenschaften

Thermal properties

Innerer Wärmewiderstand für beidseitige Kühlung

thermal resistance, junction to case for two-sided cooling

$$\Theta = 180^{\circ} \text{ el, sin}$$

$$R_{\text{thJC}} \quad \text{max. } 0,068 \quad ^{\circ}\text{C/W}$$

DC

$$\text{max. } 0,065 \quad ^{\circ}\text{C/W}$$

für anodenseitige Kühlung

for anode-sided cooling

$$\Theta = 180^{\circ} \text{ el, sin}$$

$$R_{\text{thJC(A)}} \quad \text{max. } 0,113 \quad ^{\circ}\text{C/W}$$

DC

$$\text{max. } 0,11 \quad ^{\circ}\text{C/W}$$

für kathodenseitige Kühlung

for cathode-sided cooling

$$\Theta = 180^{\circ} \text{ el, sin}$$

$$R_{\text{thJC(K)}} \quad \text{max. } 0,159 \quad ^{\circ}\text{C/W}$$

DC

$$\text{max. } 0,156 \quad ^{\circ}\text{C/W}$$

Übergangs-Wärmewiderstand

thermal resistance, case to heatsink

beidseitig/two-sided

$$R_{\text{thCK}} \quad \text{max. } 0,01 \quad ^{\circ}\text{C/W}$$

einseitig/one-sided

$$\text{max. } 0,02 \quad ^{\circ}\text{C/W}$$

Höchstzul. Sperrschichttemperatur

max. junction temperature

$$t_{vj \text{ max}} \quad 125 \quad ^{\circ}\text{C}$$

Betriebstemperatur

operating temperature

$$t_{c \text{ op}} \quad -40 \dots +125 \quad ^{\circ}\text{C}$$

Lagertemperatur

storage temperature

$$t_{\text{stg}} \quad -40 \dots +140 \quad ^{\circ}\text{C}$$

Mechanische Eigenschaften

Mechanical properties

Si-Elemente mit Druckkontakt

Si-pellet with pressure contact

Anpreßkraft

clamping force

$$F \quad 5 \dots 10 \quad \text{kN}$$

Gewicht

weight

$$G \quad \text{typ. } 100 \quad \text{g}$$

Kriechstrecke

creepage distance

$$17 \quad \text{mm}$$

Feuchteklasse

humidity classification

$$\text{DIN } 40040$$

$$\text{C}$$

Schwingfestigkeit

vibration resistance

$$f = 50 \text{ Hz}$$

$$50 \quad \text{m/s}^2$$

Maßbild, anliegend

outline, attached

$$\text{DIN } 41814-152 \text{ A4}$$

* Für größere Stückzahlen Liefertermin erfragen / Delivery for larger quantities on request



Bild / Fig. 1
Grenzdurchlaßkennlinie / Limiting on-state characteristic
 $i_T = f(v_T)$, $t_{vj} = t_{vj \max}$



Bild / Fig. 2
Durchlaßverlustleistung / On-state power loss $P_{TAV} = f(I_{TAV})$
Parameter: Stromflußwinkel / Current conduction angle θ

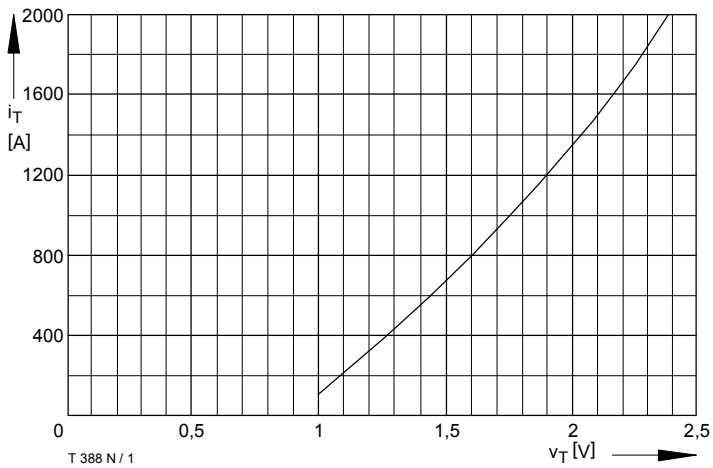

Bild / Fig. 3
Höchstzulässige Gehäusetemperatur / Max. allowable case temperature
 $t_C = f(I_{TAVM})$
Beidseitige Kühlung / Two-sided cooling
Parameter: Stromflußwinkel / Current conduction angle θ

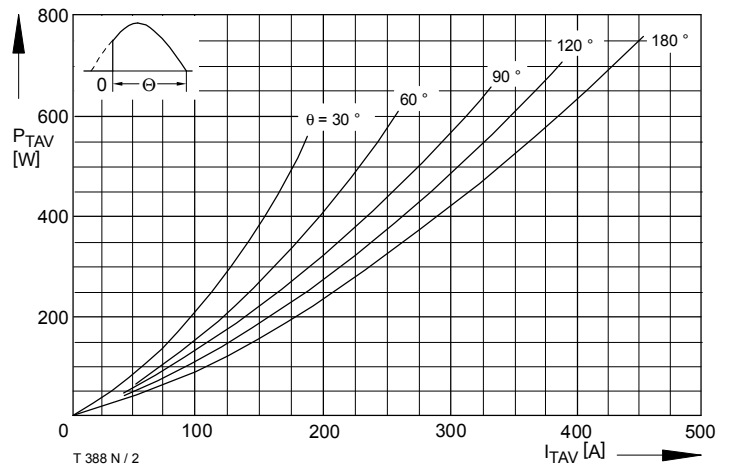

Bild / Fig. 4
Höchstzulässige Gehäusetemperatur / Max. allowable case temperature
 $t_C = f(I_{TAVM})$
Anodenseitige Kühlung / Anode-sided cooling
Parameter: Stromflußwinkel / Current conduction angle θ

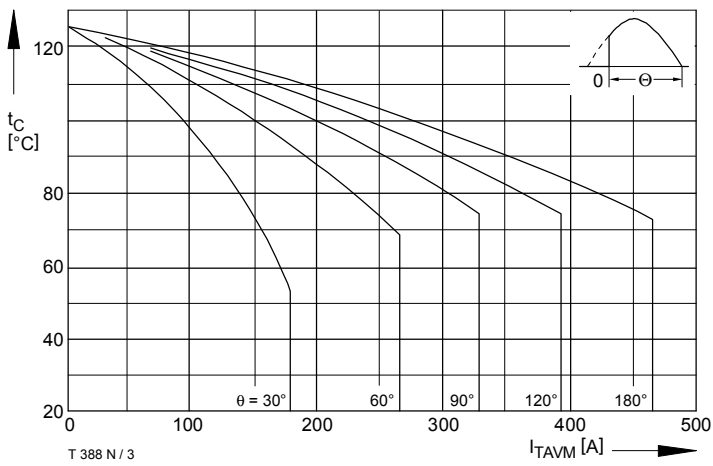

Bild / Fig. 5
Höchstzulässige Kühlmitteltemperatur / Max. allowable cooling medium temperature $t_A = f(I_{TAVM})$
Luftselbstkühlung / Natural air-cooling
Kühlkörper / Heatsink: K0.36S
Parameter: Stromflußwinkel / Current conduction angle θ

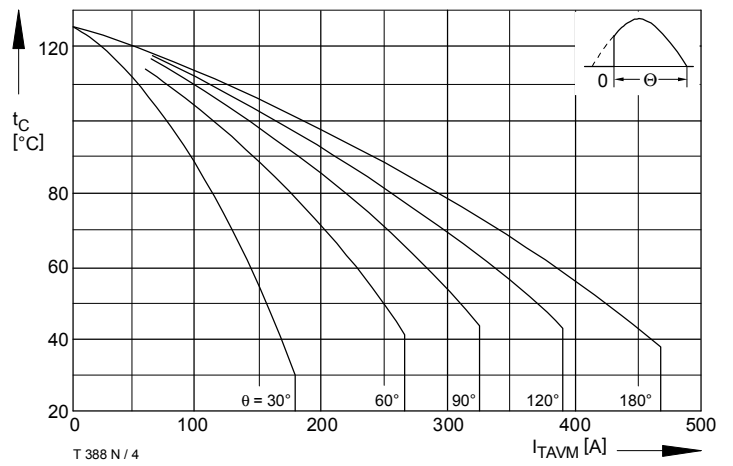

Bild / Fig. 6
Höchstzulässige Kühlmitteltemperatur / Max. allowable cooling medium temperature $t_A = f(I_{TAVM})$
Verstärkte Luftkühlung / Forced air cooling
Kühlkörper / Heatsink: K0.12F, $V_L = 50$ l/s
Parameter: Stromflußwinkel / Current conduction angle θ

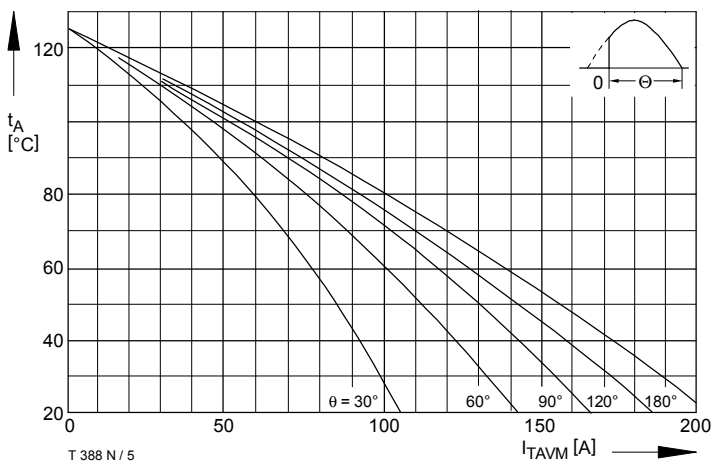

Bild / Fig. 7
 Durchlaßverlustleistung / On-state power loss $P_{TAV} = f(I_{TAV})$
 Parameter: Stromflußwinkel / Current conduction angle θ

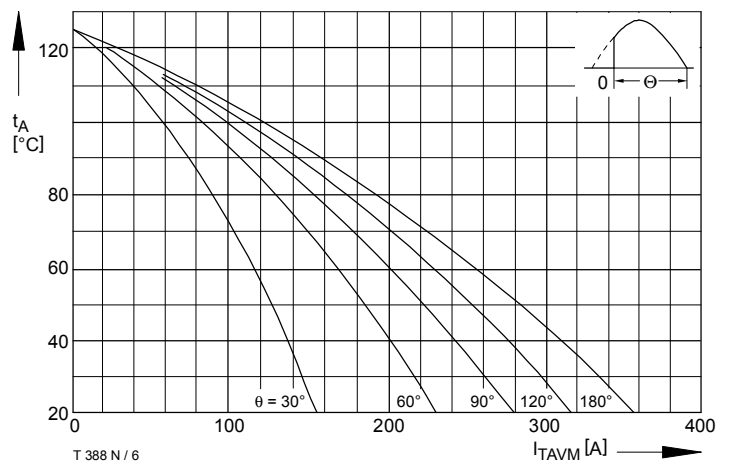

Bild / Fig. 8
 Höchstzulässige Gehäusetemperatur / Max. allowable case temperature
 $t_C = f(I_{TAVM})$
 Beidseitige Kühlung / Two-sided cooling
 Parameter: Stromflußwinkel / Current conduction angle θ

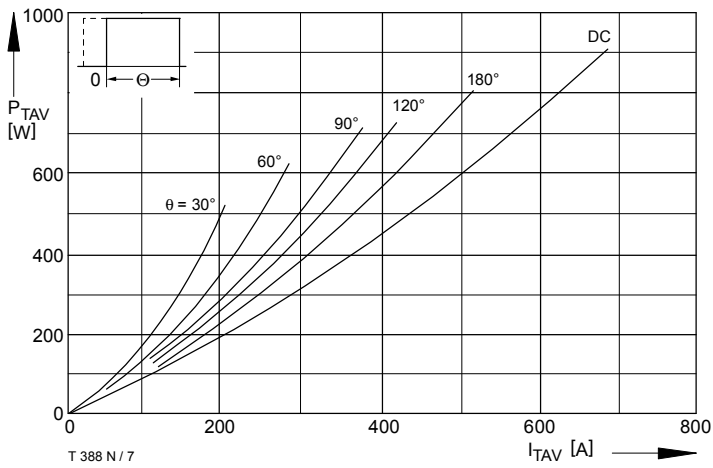

Bild / Fig. 9
 Höchstzulässige Gehäusetemperatur / Max. allowable case temperature
 $t_C = f(I_{TAVM})$
 Anodenseitige Kühlung / Anode-sided cooling
 Parameter: Stromflußwinkel / Current conduction angle θ

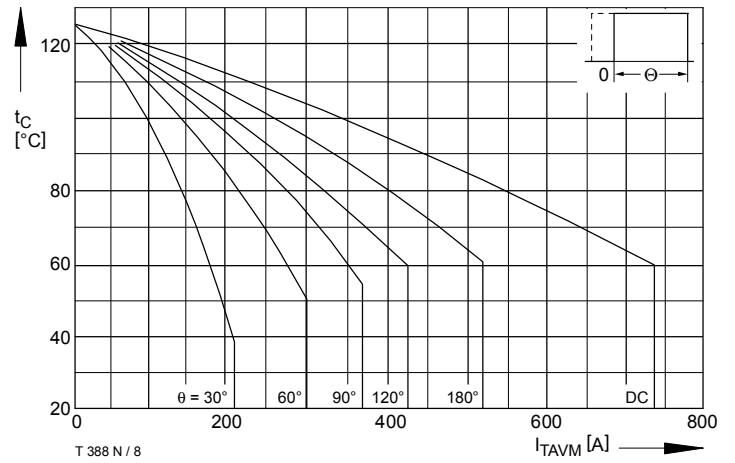

Bild / Fig. 10
 Höchstzulässige Kühlmitteltemperatur / Max. allowable cooling medium
 temperatur $t_A = f(I_{TAVM})$
 Luftselbstkühlung / Natural air-cooling
 Kühlkörper / Heatsink: K0.36S
 Parameter: Stromflußwinkel / Current conduction angle θ

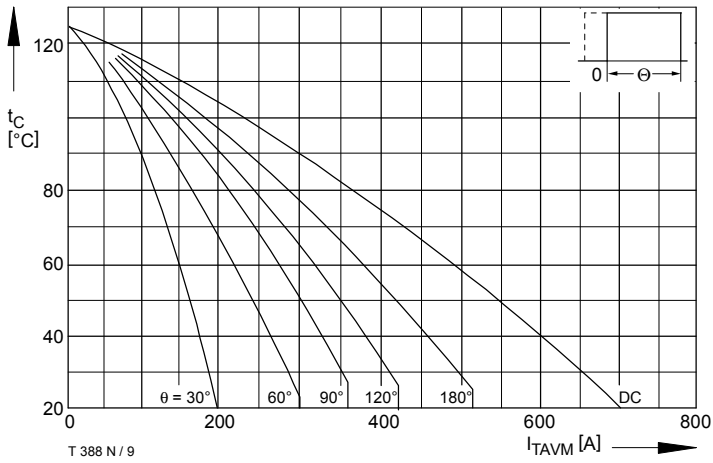

Bild / Fig. 11
 Höchstzulässige Kühlmitteltemperatur / Max. allowable cooling medium
 temperatur $t_A = f(I_{TAVM})$
 Verstärkte Luftkühlung / forced air cooling
 Kühlkörper / Heatsink: K0.12F, $V_L = 50$ l/s
 Parameter: Stromflußwinkel / Current conduction angle θ

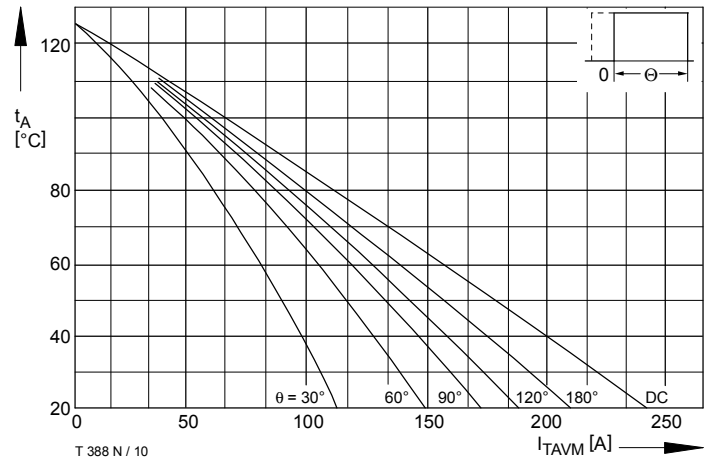

Bild / Fig. 12
 Überstrom / Overload on-state current $I_{T(OV)} = f(t)$
 Luftselbstkühlung / Natural air-cooling $t_A = 45^\circ\text{C}$
 Kühlkörper / Heatsink: K0.36S
 Parameter: Vorlaststrom / Pre-load current $I_{TAV(vor)}$

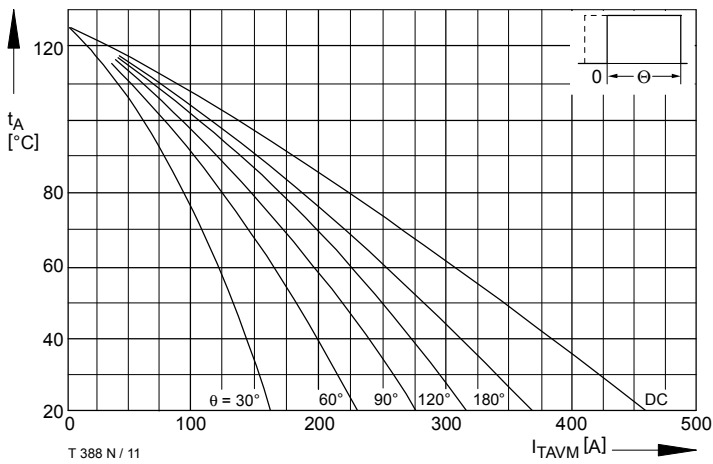

Bild / Fig. 13
 Überstrom / Overload on-state current $I_{T(OV)} = f(t)$
 Verstärkte Luftkühlung / Forced air-cooling, $t_A = 35\text{ °C}$
 Kühlkörper / Heatsink: K0.12F, $v_L = 50\text{ l/s}$
 Parameter: Vorlaststrom / Pre-load current $I_{TAV(vor)}$

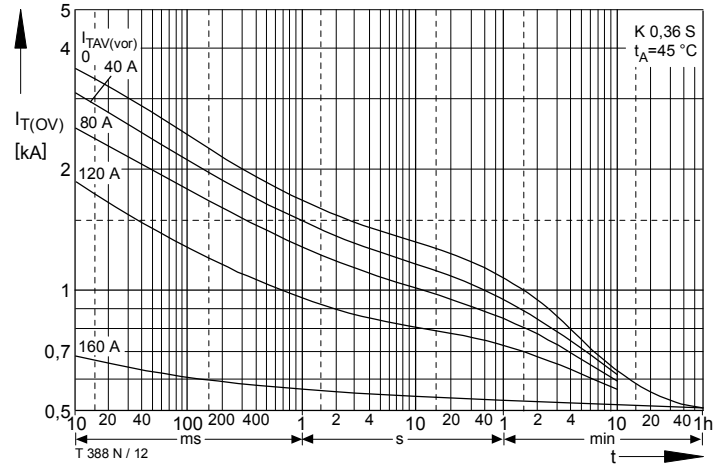

Bild / Fig. 14
 Höchstzulässiger Durchlaßstrom bei Aussetzbetrieb / Max. allowable on-state current at intermittent operation $I_{TINT} = f(ED)$
 Luftselbstkühlung / Natural air-cooling, $t_A = 45\text{ °C}$
 Kühlkörper / Heatsink: K0.36S
 Parameter: Spieldauer / Cycle duration SD
 Vorlaststrom / Pre-load current $I_{TAV(vor)}$

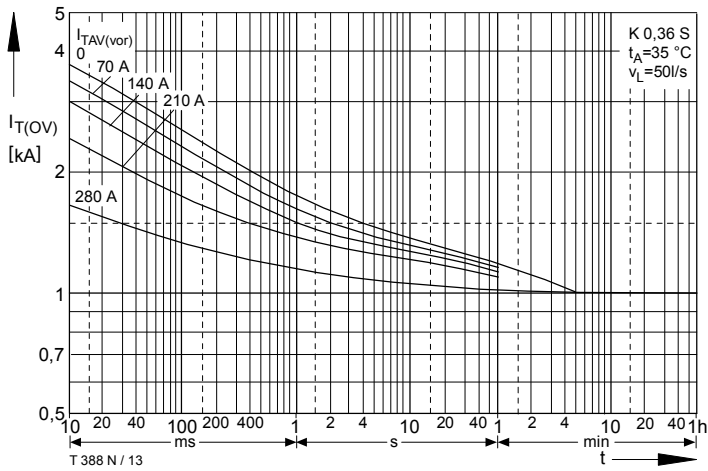

Bild / Fig. 15
 Höchstzulässiger Durchlaßstrom bei Aussetzbetrieb / Max. allowable on-state current at intermittent operation $I_{TINT} = f(ED)$
 Verstärkte Luftkühlung / Forced air-cooling, $t_A = 35\text{ °C}$
 Kühlkörper / Heatsink: K0.12F, $v_L = 50\text{ l/s}$
 Parameter: Spieldauer / Cycle duration SD
 Vorlaststrom / Pre-load current $I_{TAV(vor)}$

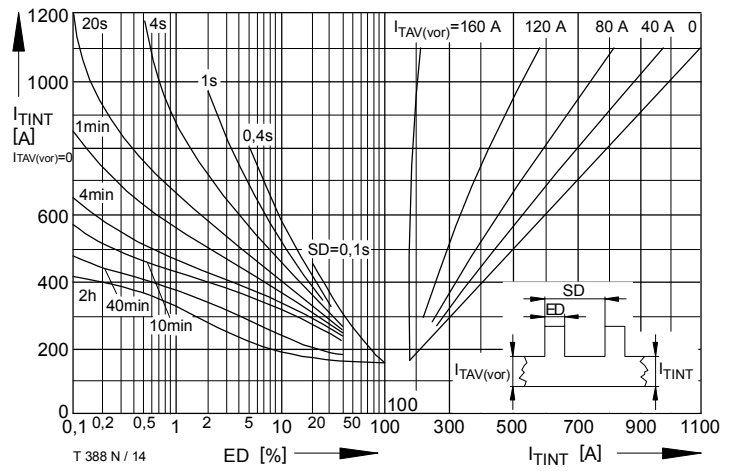

Bild / Fig. 16
 Grenzstrom / Max. overload on-state current $I_{T(OV)M} = f(t)$, $v_{RM} = 0,8\text{ }V_{RRM}$
 Beidseitige Kühlung / Two-sided cooling
 Kühlkörper / Heatsink: K0.36S, K0.12F
 Belastung aus / Surge current occurs:
 a - Leerlauf / No-load conditions
 b - Betrieb mit Dauergrenzstrom / During operation at max. average on-state current I_{TAVM}

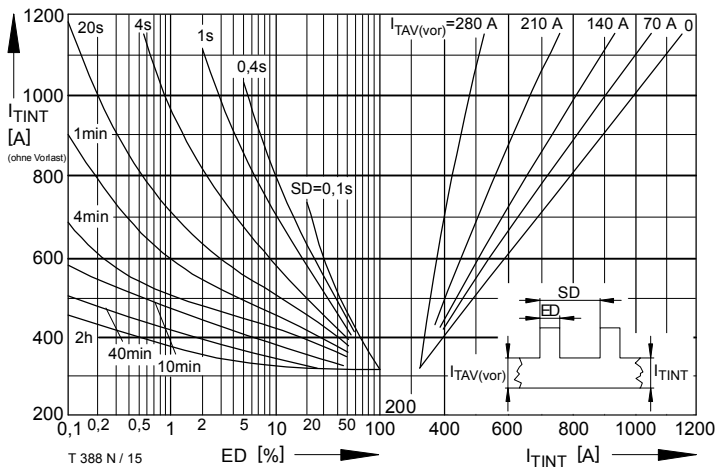

Bild / Fig. 17
 Steuercharakteristik mit Zündbereichen / Gate characteristic with triggering areas $V_G = f(i_G)$, $V_D = 6\text{ V}$
 Parameter:

	a	b	c	d
Steuerimpulsdauer / trigger puls duration t_g [ms]	10	1	0,5	0,1
Höchstzulässige Spitzensteuerverlustleistung / Max. rated peak gate power dissipation [W]	40	80	100	150

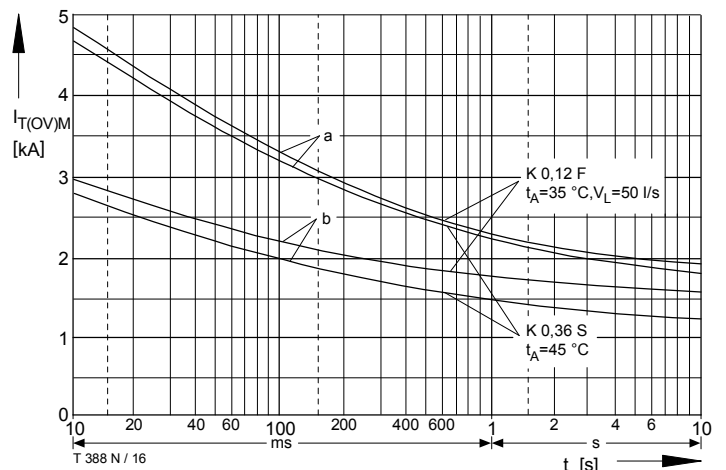

Bild / Fig. 18
 Zündverzug / Gate controlled delay time $t_{gd} = f(i_{GM})$
 $t_{vj} = 25\text{ °C}$, $di_G/dt = i_{GM}/1\mu\text{s}$
 a - Maximaler Verlauf / Limiting characteristic
 b - Typischer Verlauf / Typical characteristic

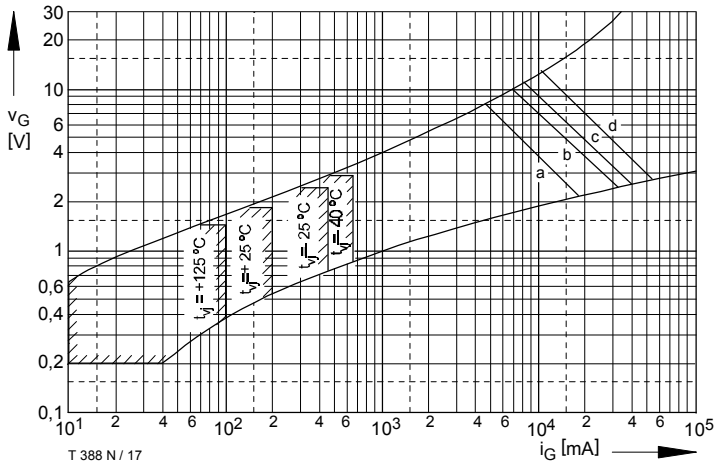

Bild / Fig. 19
 Sperrverzögerungsladung / Recovered charge $Q_r = f(di/dt)$
 $t_{vj} = t_{vj \max}$; $V_R = 0,5 V_{RRM}$; $V_{RM} = 0,8 V_{RRM}$
 Parameter: Durchlaßstrom / On-state current i_{TM}

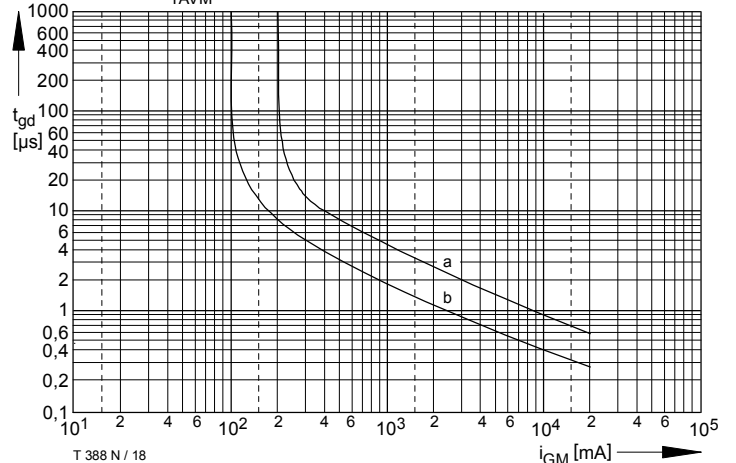

Bild / Fig. 20
 Transienter innerer Wärmewiderstand / Transient thermal impedance
 $Z_{thJC} = f(t)$
 ----- Anodenseitige Kühlung / Anode-sided cooling
 ————— Beidseitige Kühlung / Two-sided cooling
 Parameter: Stromflußwinkel / current conduction angle θ

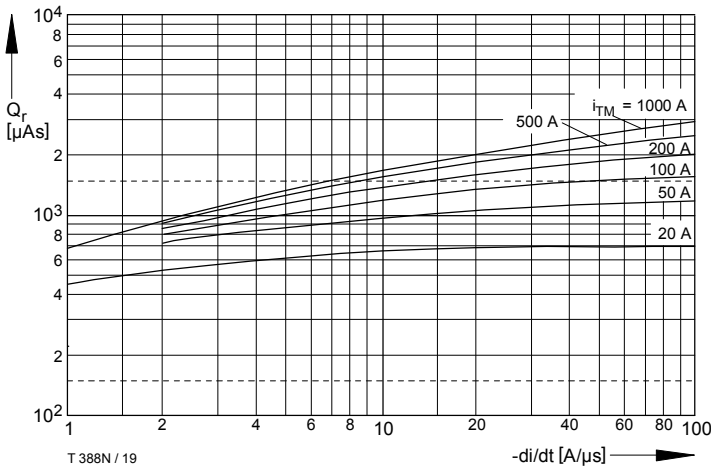

Bild / Fig. 21
 Transienter innerer Wärmewiderstand / Transient thermal impedance
 $Z_{thJC} = f(t)$
 ----- Anodenseitige Kühlung / Anode-sided cooling
 ————— Beidseitige Kühlung / Two-sided cooling
 Parameter: Stromflußwinkel / current conduction angle θ

Analytische Elemente des transienten Wärmewiderstandes Z_{thJC} pro Zweig für DC
 Analytical elements of transient thermal impedance Z_{thJC} per arm for DC

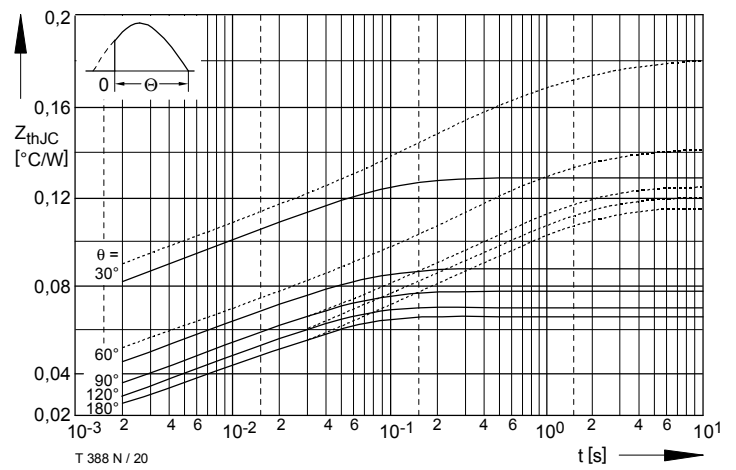
Beidseitig / Two-sided

Pos. n	1	2	3	4	5	6
R_{thn} [$^{\circ}\text{C}/\text{W}$]	0,00832	0,0151	0,0181	0,0207	0,00286	
τ_n [s]	0,000826	0,0166	0,0808	0,359	1,957	

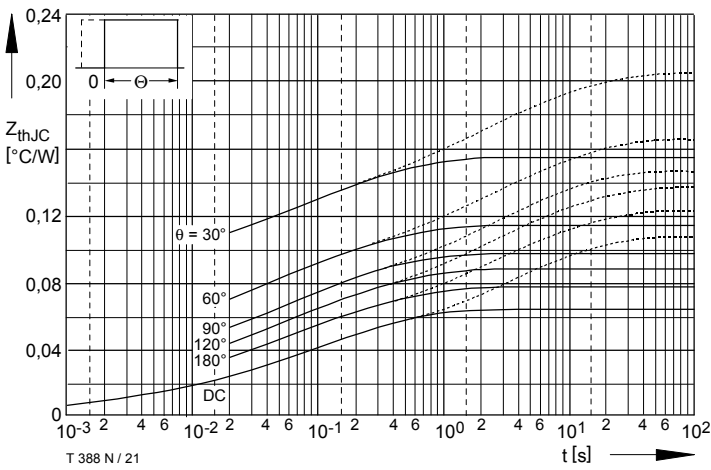
Anodenseitig / Anode-sided

Pos. n	1	2	3	4	5	6
R_{thn} [$^{\circ}\text{C}/\text{W}$]	0,00961	0,00543	0,0209	0,0142	0,0271	0,0328
τ_n [s]	0,00104	0,0133	0,0364	0,23	1,52	10,5

Kathodenseitig / Cathode-sided

Pos. n	1	2	3	4	5	6
R_{thn} [$^{\circ}\text{C}/\text{W}$]	0,0098	0,0186	0,0157	0,0617	0,0502	
τ_n [s]	0,00106	0,0027	0,0994	2,04	10,2	

Analytische Funktion / Analytical function:

$$Z_{thJC} = \sum_{n=1}^{n_{\max}} R_{thn} \left(1 - e^{-\frac{t}{\tau_n}}\right)$$

Terms & Conditions of Usage

Attention

The present product data is exclusively subscribed to technically experienced staff. This Data Sheet is describing the specification of the products for which a warranty is granted exclusively pursuant the terms and conditions of the supply agreement. There will be no guarantee of any kind for the product and its specifications. Changes to the Data Sheet are reserved.

You and your technical departments will have to evaluate the suitability of the product for the intended application and the completeness of the product data with respect to such application. Should you require product information in excess of the data given in the Data Sheet, please contact your local Sales Office via "www.eupec.com / sales & contact".

Warning

Due to technical requirements the products may contain dangerous substances. For information on the types in question please contact your local Sales Office via "www.eupec.com / sales & contact".