

Control IC for Single-Ended and Push-Pull Switched-Mode Power Supplies (SMPS)

TDA 4700
TDA 4718

Features

- Feed-forward control (line hum suppression)
- Symmetry inputs for push-pull converter (TDA 4700)
- Push-pull outputs
- Dynamic output current limitation
- Overvoltage protection
- Undervoltage protection
- Soft start
- Double pulse suppression

Type	Ordering Code	Package	Temp.-Range
TDA 4700 A	Q67000-Y594	P-DIP-24-1	- 0 to 70 °C
■ TDA 4718 A	Q67000-Y639	P-DIP-18-1	- 0 to 70 °C

■ Not for new design

These versatile SMPS control ICs comprise digital and analog functions which are required to design high-quality flyback, single-ended and push-pull converters in normal, half-bridge and full-bridge configurations. The component can also be used in single-ended voltage multipliers and speed-controlled motors. Malfunctions in electrical operation are recognized by the integrated operational amplifiers, which activate protective functions.

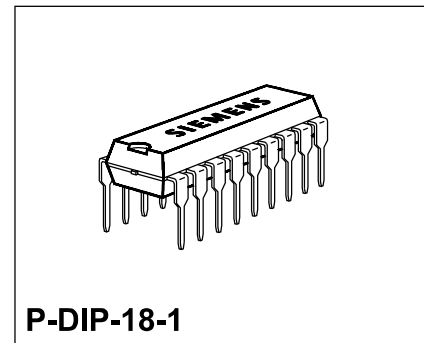
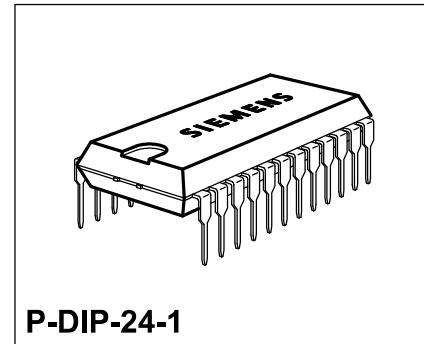

¹⁾ Is now available for temperature range - 25 to 85 °C.

Pin Configuration (TDA 4700)
(top view)

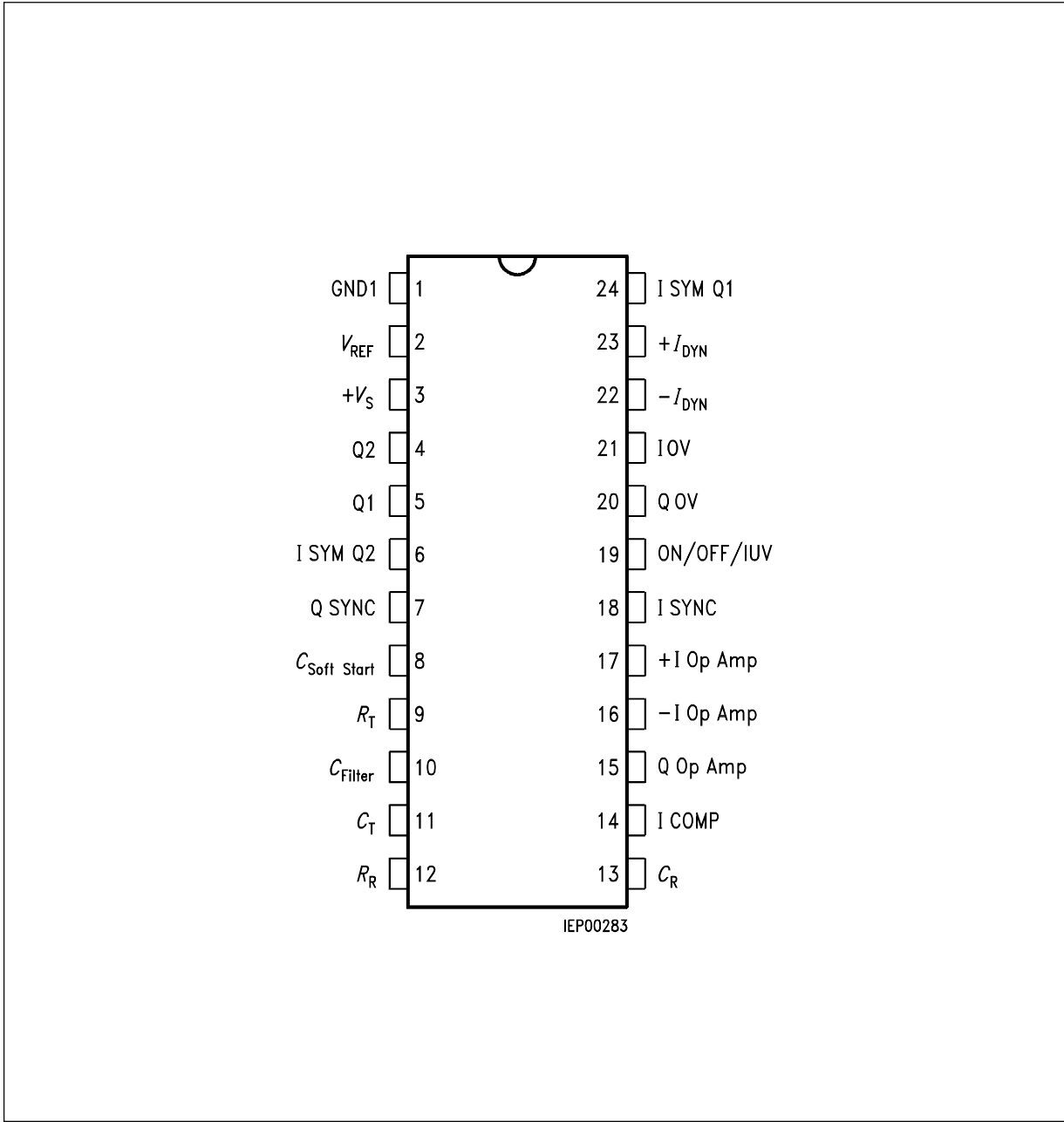

Pin Definitions and Functions (TDA 4700)

Pin	Symbol	Function
1	GND	Ground 0 V
2	$+ V_{REF}$	Reference voltage
3	$+ V_S$	Supply voltage
4	Q2	Output Q2
5	Q1	Output Q1
6	I SYM Q2	Symmetry Q2
7	Q SYNC	Sync. output
8	$C_{soft\ start}$	Soft start
9	R_T	VCO R_T
10	C_{filter}	Capacitance
11	C_T	VCO C_T
12	R_R	Ramp generator R_R
13	C_R	Ramp generator C_R
14	I COMP	Comparator input
15	Q Op Amp	Operational amplifier output
16	- I Op Amp	Operational amplifier input (-)
17	+ I Op Amp	Operational amplifier input (+)
18	I SYNC	Sync. input
19	ON/OFF/IUV	ON/OFF, undervoltage
20	QOV	Overvoltage output
21	IOV	Overvoltage input
22	$- I_{DYN}$	Dynamic current limitation (-)
23	$+ I_{DYN}$	Dynamic current limitation (+)
24	I SYM Q1	Symmetry

Pin Configuration (TDA 4718)
(top view)

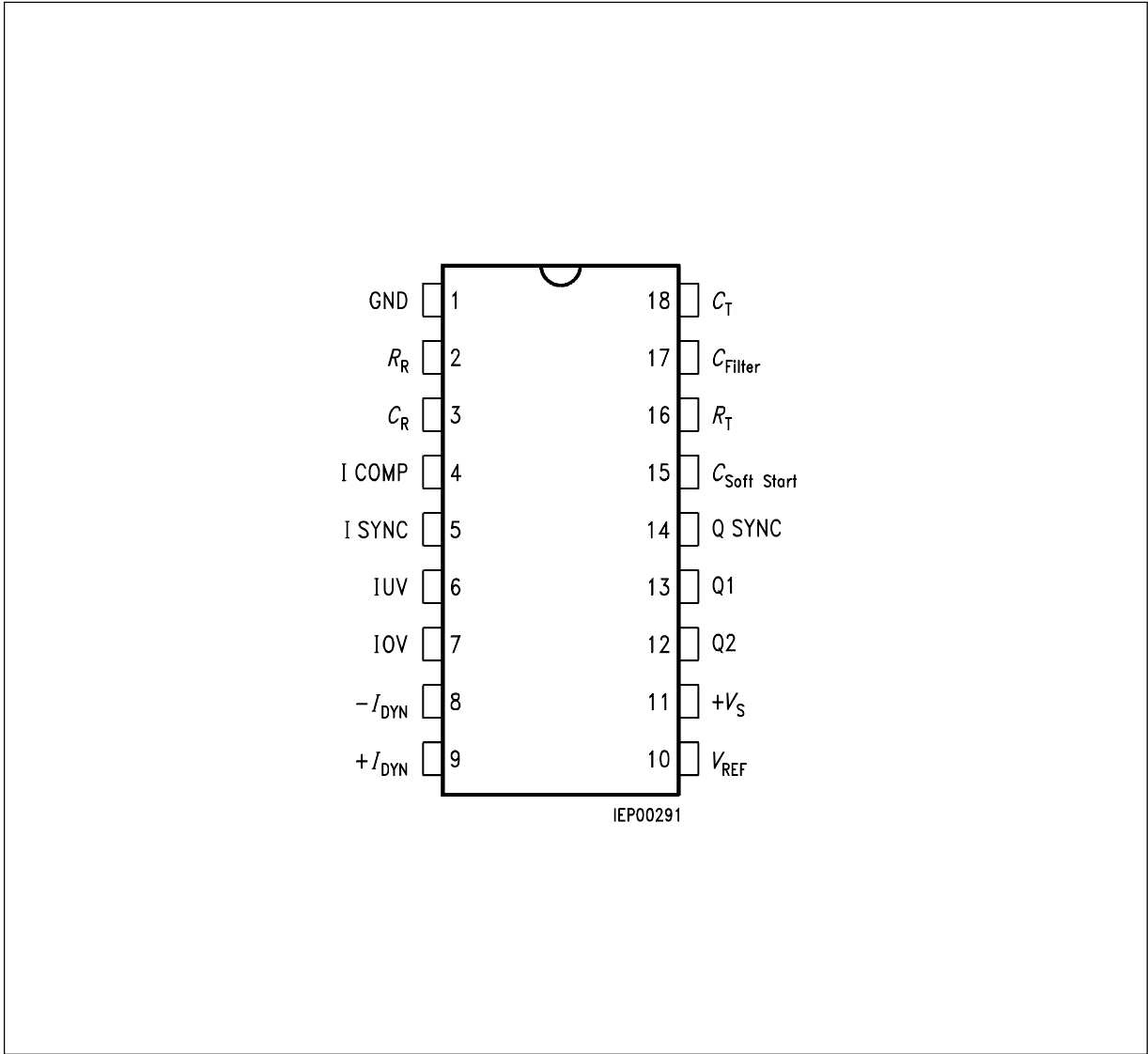

Pin Definitions and Functions (TDA 4718)

Pin	Symbol	Function
1	GND	Ground 0 V
2	R_R	Ramp generator R_R
3	C_R	Ramp generator C_R
4	I COMP	+ Input comparator K2
5	I SYNC	Sync. input
6	IUV	Input undervoltage, ON/OFF
7	IOV	Input overvoltage
8	$- I_{DYN}$	Input dynamic current limitation (-)
9	$+ I_{DYN}$	Input dynamic current limitation (+)
10	$+ V_{REF}$	Reference voltage
11	$+ V_S$	Supply voltage
12	Q 2	Output Q2
13	Q 1	Output Q1
14	Q SYNC	Sync. output
15	$C_{soft\ start}$	Soft start
16	R_T	VCO R_T
17	C_{filter}	Capacitance
18	C_T	VCO C_T

Circuit Description

Voltage Controlled Oscillator (VCO)

The VCO generates a sawtooth voltage. The duration of the falling edge is determined by the value of C_T . The duration of the rising edge of the waveform and, therefore, approximately the frequency, is determined by the value of R_T . By varying the voltage at C_{filter} , the oscillator frequency can be changed by its rated value. During the fall time, the VCO provides a trigger signal for the ramp generator, as well as an L signal for a number of IC parts to be controlled.

Ramp Generator

The ramp generator is triggered by the VCO and oscillates at the same frequency. The duration of the falling edge of the ramp generator waveform is to be shorter than the fall time of the VCO. To control the pulse width at the output, the voltage of the rising edge of the ramp generator signal is compared with a DC voltage at comparator K2. The slope of the rising edge of the ramp generator signal is controlled by the current through R_R . This offers the possibility of an additional, superimposed control of the output duty cycle. This additional control capability, called “feed-forward control”, is utilized to compensate for known interference such as ripple on the input voltage.

Phase Comparator

If the component is operated without external synchronization, the sync input must be connected to the sync output for the phase comparator to set the rated voltage at C_{filter} . The VCO then oscillates with rated frequency. In the case of external synchronization, other components can be synchronized with the sync output. The component can be frequency-synchronized, but not phase-synchronized, with the sync input. The duty cycle of the squarewave voltage at the sync input is arbitrary. The best stability as to small phase and frequency interference deviation is achieved with a duty cycle as offered by the sync output.

Push-Pull Flipflop

The push-pull flipflop is switched by the falling edge of the VCO. This ensures that only one output of the two push-pull outputs is enabled at a time.

Comparator K2

The two plus inputs of the comparator are switched such that the lower plus level is always compared with the level of the minus input. As soon as the voltage of the rising sawtooth edge exceeds the lower of the two plus levels, both outputs are disabled via the pulse turn-off flipflop. The period during which the respective, active outputs is low can be infinitely varied. As the frequency remains constant, this process corresponds to a change in duty cycle.

Operational Amplifier K1 (TDA 4700; A)

The K1 op amp is a high-quality amplifier. Fluctuations in the output voltage of the power supply are amplified by K1 and applied to the free + input of comparator K2. Variations in output voltage are, in this way, converted to a corresponding change in output duty cycle. K1 has a common-mode input voltage range between 0 V and + 5 V.

Pulse-Turn-OFF Flipflop

The pulse turn-OFF flipflop enables the outputs at the start of each half cycle. If an error signal from comparator K7 or a turn-off signal from K2 is present, the outputs will immediately be switched off.

Comparator K3

Comparator K3 limits the voltage at capacitance $C_{\text{soft start}}$ (and also at K2) to a maximum of + 5 V. The voltage at the ramp generator output may, however rise to 5.5 V. With a corresponding slope of the rising ramp generator edge, the duty cycle can be limited to a desired maximum value.

Comparator K4

The comparator has its switching threshold at 1.5 V and sets the error flipflop with its output if the voltage at capacitance $C_{\text{soft start}}$ is below 1.5 V. However, the error flipflop accepts the set signal only if no reset pulse (error) is applied. In this way the outputs cannot be turned on again as long as an error signal is present.

Soft Start

The lower one of the two voltages at the plus inputs of K2 is a measure for the duty cycle at the output. At the instant of turning on the component, the voltage at capacitor $C_{\text{soft start}}$ equals 0 V. As long as no error is present, this capacitor is charged with a current of 6 μA to the maximum value of 5 V. In case of an error, $C_{\text{soft start}}$ is discharged with a current of 2 μA . A set signal is pending at the error flipflop below a charge of 1.5 V and the outputs are enabled if no reset signal is pending simultaneously. As the minimum ramp generator voltage, however, is 1.8 V, the duty cycle at the outputs is actually increased slowly and continuously not before the voltage at $C_{\text{soft start}}$ exceeds 1.8 V.

Error Flipflop

Error signals, which are led to input \bar{R} of the error flipflop cause an immediate disabling of the outputs, and after the error has been eliminated, cause the component to switch on again by the soft start.

Comparator K5, K6, K8, V_{REF} Overcurrent Load

These are error detectors which cause immediate disabling of the outputs via the error flipflop when an error occurs. After elimination of the error, the component switches on again using the soft start. The output of K5 can be fed back to the input. This causes the IC output stage to remain disabled even after elimination of the overvoltage. However, it requires high-ohmic overvoltage coupling.

Comparator K7

K7 serves to recognize overcurrents. This is the reason why both inputs of the op amp have been brought out. Turning on is resumed after error recovery at the beginning of the next half period but without using the soft start.

K7 has a common-mode range covers 0 V and +4 V. The delay time between occurrence of an error and disabling of the outputs is only 250 ns.

Symmetry (TDA 4700; A)

In push-pull converters, a saturation of the transformer core must be prevented. The degree of saturation of the transformer can be determined with an external circuit, thus the active periods of the outputs can be decreased unsymmetrically at the symmetry inputs.

Outputs

Both outputs are transistors with open collectors and operate in a push-pull arrangement. They are active low. The time in which only one of the two outputs is conductive can be varied infinitely. The length of the falling edge at VCO is equal to the minimum time during which both outputs are disabled simultaneously. The minimum L voltage is 0.7 V.

Reference Voltage

The reference voltage source is a highly constant source with regard to its temperature behavior. It can be utilized in the external wiring of the op amp, the error comparators, the ramp generator, or other external components.

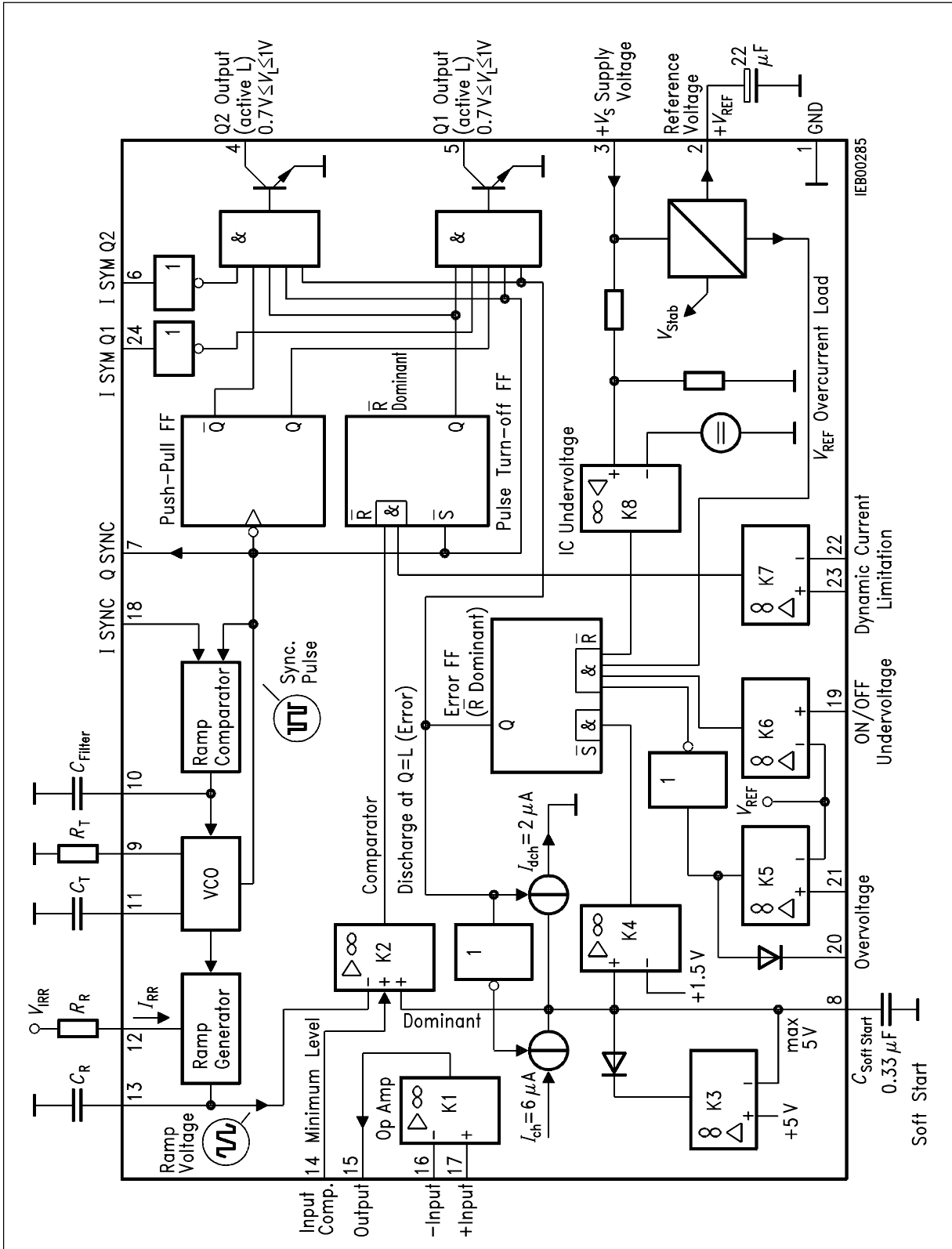

Block Diagram (TDA 4700)

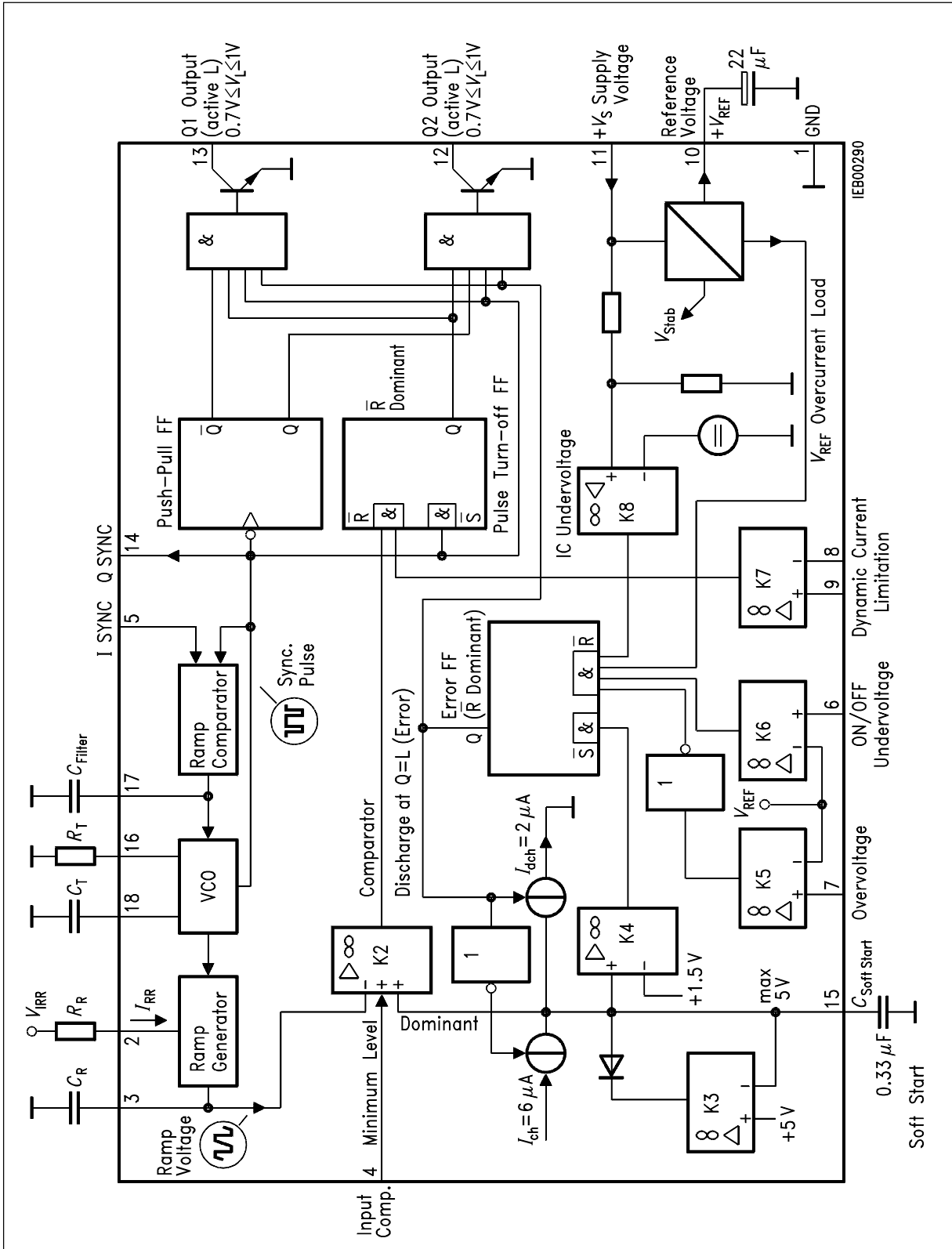

Block Diagram (TDA 4718)

Absolute Maximum Ratings

Parameter	Symbol	Limit Values		Unit	Test Condition
		min.	max.		
Supply voltage	V_S	- 0.3	33	V	
Voltage at Q1, Q2	V_Q	- 0.3	33	V	Q1, Q2 high
Current at Q1, Q2	I_Q		70	mA	Q1, Q2 low
Symmetry 1, 2 TDA 4700; A	V_{SYM}	- 0.3	33	V	
Sync output	$V_{SYNC Q}$ $I_{SYNC Q}$	- 0.3 0	7 10	V mA	SYNC Q high SYNC Q low
Sync input	$V_{SYNC I}$	- 0.3	33	V	
Input C_{filter}	$V_{I Cf}$	- 0.3	7	V	
Input R_T	$V_{I RT}$	- 0.3	7	V	
Input C_T	$V_{I CT}$	- 0.3	7	V	
Input R_R	$V_{I RR}$	- 0.3	7	V	
Input C_R	$I_{I CR}$	- 10	10	mA	
Input comparator K2, K5, K6, K7	V_{IK}	- 0.3	33	V	
Output K5	$V_{Q K5}$	- 0.3	33	V	
Input op amp TDA 4700; A	$V_{I Op Amp}$	- 0.3	33	V	
Output op amp TDA 4700; A	$V_{Q Op Amp}$	- 0.3	$V_S - 1$ max. 7	V V	
Reference voltage	V_{REF}	- 0.3	V_{REF}	V	
Input $C_{soft start}$	$V_{I soft start}$	- 0.3	7	V	
Junction temperature	T_j		150	°C	
Storage temperature	T_{stg}	- 55	125	°C	
Thermal resistance system - air TDA 4700; A TDA 4718 TDA 4718 A	$R_{th SA}$ $R_{th SA}$ $R_{th SA}$		65 70 60	K/W K/W K/W	

Operating Range

Parameter	Symbol	Limit Values		Unit	Test Condition
		min.	max.		
Supply voltage	V_S	10.5	30	V	
Ambient temperature					
TDA 4700	T_A	-25	85	°C	
TDA 4718	T_A	0	70	°C	
TDA 4700 A	T_A				
TDA 4718 A	T_A				
VCO frequency	f	40	250 000	Hz	
Ramp generator frequency	f_{RG}	40	250 000	Hz	

Characteristics

$V_S = 11$ to 30 V; $T_A = -25$ to 85 °C

Parameter	Symbol	Limit Values			Unit	Test Condition
		min.	typ.	max.		
Supply current	I_S	8		20	mA	$C_T = 1$ nF $f_{VCO} = 100$ kHz

Reference

Reference voltage	V_{REF}	2.35	2.5	2.65	V	$0 \text{ mA} < I_{REF} < 5 \text{ mA}$
Reference voltage change	ΔV_{REF}		8		mV	$14 \text{ V} \pm 20 \%$
Reference voltage change	ΔV_{REF}		15		mV	$25 \text{ V} \pm 20 \%$
Reference voltage change	ΔV_{REF}			15 ¹⁾	mV	$0 \text{ mA} < I_{REF} < 5 \text{ mA}$
Temperature coefficient	TC		0.25	0.4	mV/K	
Response threshold of I_{REF} overcurrent	I_{REF}		10		mA	

¹⁾ At $T_A = 0$ to 70 °C, this value falls to max. 5 mV

Characteristics (cont'd)

$V_S = 11$ to 30 V; $T_A = -25$ to 85 °C

Parameter	Symbol	Limit Values			Unit	Test Condition
		min.	typ.	max.		

Oscillator (VCO)

Frequency range	f_{VCO}	40		100 000	Hz	
Frequency change	Δf_{VCO}		0.5		%	14 V \pm 20 %
Frequency change	Δf_{VCO}	-1		1	%	25 V \pm 20 %
Tolerance	Δf_{VCO}	-7		7	%	$\Delta R_T = 0$; $\Delta C_T = 0$
Fall time sawtooth	t		1		μ s	$C_T = 1$ nF
	t		10		μ s	$C_T = 10$ nF
RC combination	C_T	0.82		47	nF	
VCO	R_T	5		700	k Ω	

Ramp Generator

Frequency range	f	40		100 000	Hz	
Maximum voltage at C_R	V_H		5.5		V	
Minimum voltage at C_R	V_L		1.8		V	
Input current through R_R	I_{RR}	0		400	μ A	
Current transformation ratio	I_{RR}/I_{CR}		1/4			

Synchronization

Sync output	V_{QH}	4			V	$I_{QH} = -200$ μ A
	V_{QL}			0.4	V	$I_{QL} = 1.6$ mA
Sync input	V_{IH}	2			V	
	V_{IL}			0.8	V	
Input current	$-I_I$			5	μ A	

Characteristics (cont'd)

$V_S = 11$ to 30 V; $T_A = -25$ to 85 °C

Parameter	Symbol	Limit Values			Unit	Test Condition
		min.	typ.	max.		

Comparator K2

Input current	$-I_{IK2}$			2	μ A	for duty cycle $D = 0$ $D = \text{max.}$
Turn-OFF delay ¹⁾	$t_{D\text{OFF}}$			500	ns	
Input voltage	V_{IK2}		1.8 5		V V	
Common-mode input voltage range	V_{IC}	0		5.5	V	

Soft Start K3, K4

Charge current for $C_{\text{soft start}}$	I_{ch}		6		μ A	
Discharge current for $C_{\text{soft start}}$	I_{dch}		2		μ A	
Upper limiting voltage	V_{lim}		5		V	
Switching voltage K4	V_{K4}		1.5		V	

Operational Amplifier K1 (TDA 4700; TDA 4700 A)

Open-loop voltage gain	G_{V0}	60	80		dB	
Input offset voltage	V_{IO}	-10		10	mV	
Temperature coefficient of V_{IO}	TC	-30		30	μ V/K	
Input current	$-I_I$			2	μ A	
Common-mode input voltage range	V_{IC}	0		5	V	
Output current	I_Q	-3		1.5	mA	
Rise time of output voltage	$\Delta V/\Delta t$		1		V/ μ s	
Transition frequency	f_T		3		MHz	
Phase at f_T	ϕ_T		120		deg.	
Output voltage	$V_{QH/L}$	1.5		5.5	V	$-3\text{ mA} < I < 1.5\text{ mA}$

¹⁾ At the input: step function $\Delta V = -100$ mV \rightarrow $\Delta V = +100$ mV

Characteristics (cont'd)

$V_S = 11$ to 30 V; $T_A = -25$ to 85 °C

Parameter	Symbol	Limit Values			Unit	Test Condition
		min.	typ.	max.		

Symmetry (TDA 4700; TDA 4700 A)

Input voltage	V_{IH}	2.0			V	
	V_{IL}			0.8	V	
Input current	$-I_I$			2	μ A	

Output Stages Q1, Q2

Output voltage	V_{QH}			30	V	$I_Q = 20$ mA
	V_{QL}			1.1	V	
Output leakage current	I_Q			2	μ A	$V_{QH} = 30$ V

ON, OFF, Undervoltage K6

Switching voltage	V	$V_{REF} - 0.03$		$V_{REF} + 0.03$	V	
Input current	$-I_I$			2	μ A	
Turn-OFF delay time ¹⁾	$t_{D OFF}$		250		ns	
Error detection time ¹⁾	t		50		ns	

Dynamic Current Limitation K7

Common-mode input voltage range	V_{IC}	0		4	V	
Input offset voltage	V_{IO}	-10		10	mV	
Input current	$-I_I$			2	μ A	
Turn-OFF delay time ²⁾	$t_{D OFF}$		250		ns	
Error detection time ²⁾	t		50		ns	

Overvoltage K5

Switching voltage	V	$V_{REF} - 0.03$		$V_{REF} + 0.03$	V	$V_{QH min} = 5$ V
Input current	$-I_I$			2	μ A	
Output current	$-I_Q$	0		200	μ A	
Turn-OFF delay time ¹⁾	$t_{D OFF}$		250		ns	
Error detection time ¹⁾	t		50		ns	

¹⁾ At the input: step function $\Delta V = V_{REF} - 100$ mV \rightarrow $V_{REF} + 100$ mV

²⁾ At the input: step function $\Delta V = -100$ mV \rightarrow $\Delta V = +100$ mV

Characteristics (cont'd)

$V_S = 11$ to 30 V; $T_A = -25$ to 85 °C

Parameter	Symbol	Limit Values			Unit	Test Condition
		min.	typ.	max.		

Supply Undervoltage

Turn-ON threshold for V_S rising	V_S	8.8		11 10.5	V V	$0\text{ °C} < T_A < 70\text{ °C}$
Turn-OFF threshold for V_S falling	V_S	8.5		10.5 10	V V	$0\text{ °C} < T_A < 70\text{ °C}$

Input C_{filter}

Rated voltage for rated frequency Frequency approx. proportional to voltage within the range Voltage at open sync input	V_R		4		V	
	V_R	3		5	V	
	$V_{C\text{ filter}}$		1.6		V	

Dimensioning Notes for RC Network

1. Determination of the minimum time during which both outputs must be disabled
→ selection of C_T ; selection of $C_R \leq C_T$.
2. Determination of the VCO frequency = 2 x output frequency
→ selection of R_T .
3. Determination of the rated slope of the rising ramp generator voltage, which the maximum possible turn-on period per half wave depends on
→ selection of R_R .
4. Duration of the soft start process
→ selection of $C_{\text{soft start}}$.
5. In the case of a free-running VCO: connect sync output with sync input.
6. Wiring of the op amp according to the dynamic requirements and connection of its output with the free input of K2. (TDA 4700; TDA 4700 A)
7. Capacitance C_{filter} is not required in the free-running operation (sync input connected with sync output).

In the case of external synchronization, that value depends on the selected operating frequency and the required maximum phase interference deviation.

Rated VCO frequency:	100 kHz	50 Hz
C_{filter} favourable:	10 nF	1 μ F

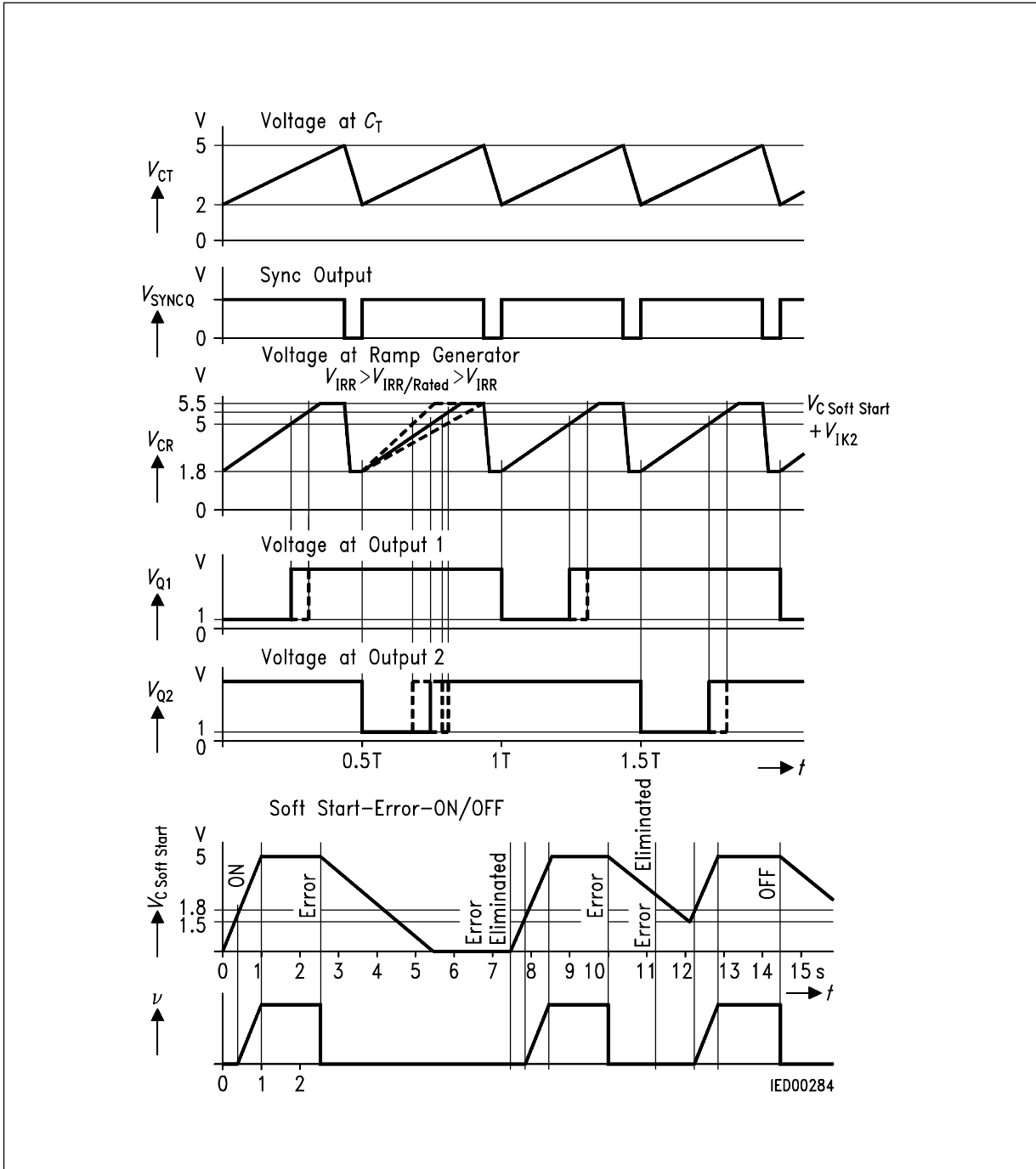

Pulse Diagram

VCO Frequency versus R_T and C_T

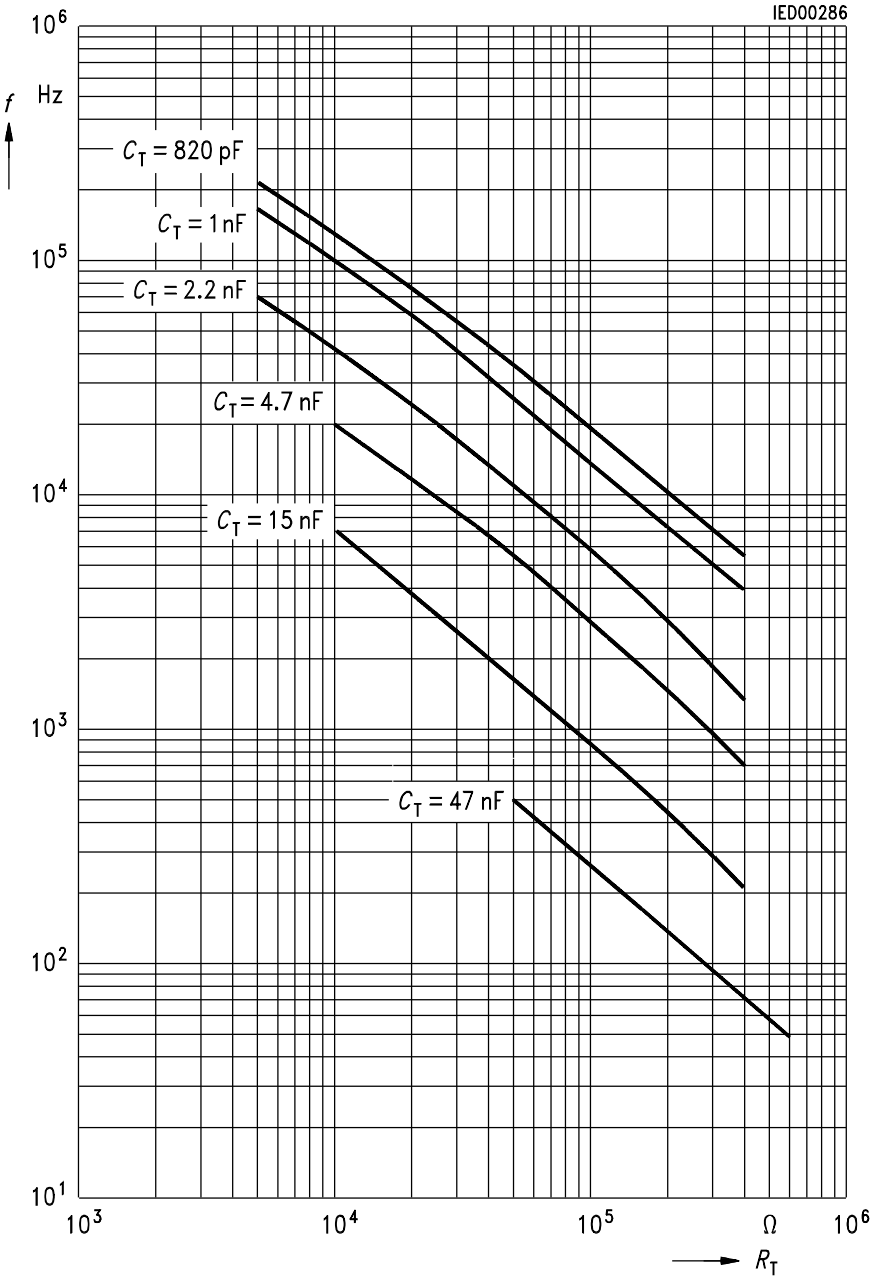

VCO Temperature Response

$V_S = 12\text{ V}; D = \text{max.}$

$$\frac{\Delta f_{VCO}}{f_K \times K} [1/K] \text{ with } C_T \text{ as parameter}$$

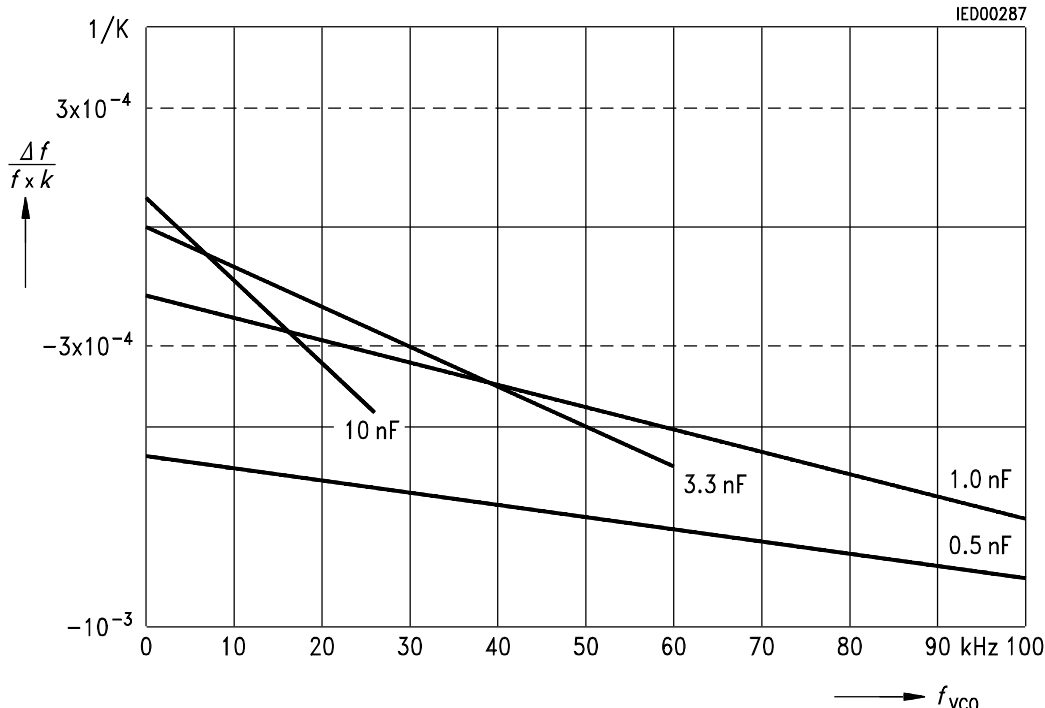

Current Consumption
versus Temperature

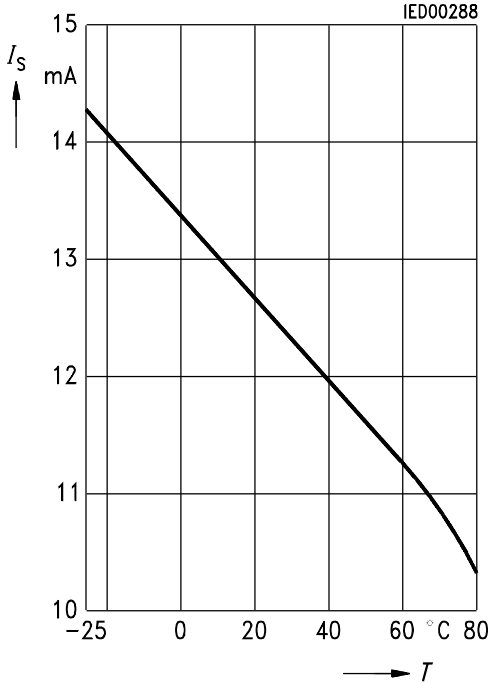

Output Current versus
Output Voltage

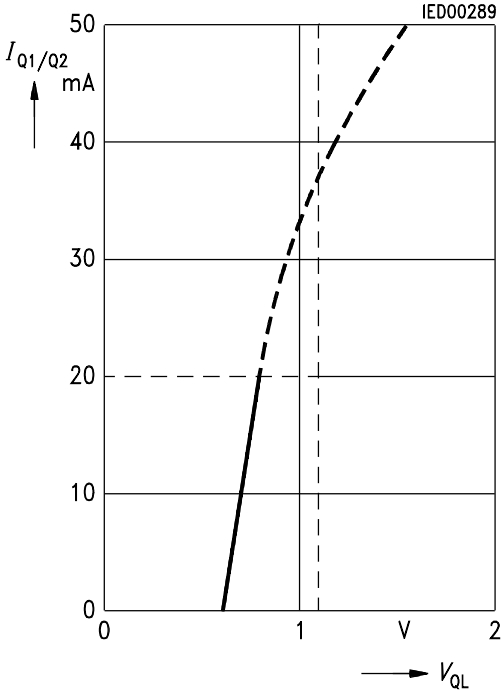

This datasheet has been downloaded from:

www.DatasheetCatalog.com

Datasheets for electronic components.